

3.3.5 Connecting the Emergency Vent. Valve

The emergency vent. valve stops the STP pump by introducing gases if any abnormality/error occurs in the STP pump.

Connect the emergency vent. valve (contained in the attached accessories) to the purge port as shown in Figure 3.7. Note that the side of the emergency vent. valve without filter is connected to the purge port.

Connect the cable for the emergency vent. valve to the connector, LEAK VALVE CON8A, of the STP control unit.



- ◇ Always attach the emergency vent. valve.
- ◇ DO NOT close the port of the emergency vent. valve (filter side) with a blank flange or other type of device.



- ◇ The allowable gas pressure ranges from zero (atmospheric pressure) to 0.5 kgf/cm² (gauge pressure).
- ◇ Use a dry N₂ gas or atmospheric air.

3.3.6 Connecting the Purge Port

When sucking reactive or corrosive gases, introduce a dry N₂ gas or other gas into the STP pump in order to protect the inside of the STP pump.

As shown in Figure 3.7, introduce a dry N₂ gas through the electromagnetic vent. valve, needle valve or similar valve (must be prepared by the customer) from the purge port.

For instructions on how to introduce the purge gas, See [Section 7.1, "Gas Suction."](#)

NOTICE

- ◇ The proper amount of gas purge is approx. $3.4 \times 10^{-2} \text{ Pa}\cdot\text{m}^3/\text{sec}$. (20 SCCM).
- ◇ The allowable gas pressure ranges from zero (atmospheric pressure) to 0.5 kgf/cm^2 (gauge pressure).
- ◇ When not introducing the purge gas, close the purge port with the blank flange (attached at delivery).

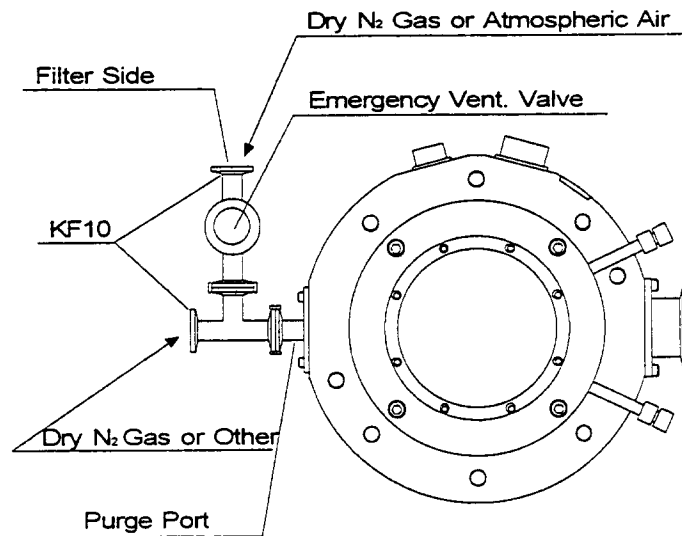

Figure 3.7 Connecting the Purge Port and Emergency Vent. Valve

3.3.7 Connecting the Ground Cable

Connect the ground cable (yellow/green) between the ground terminal of the STP pump and the ground terminal of the STP control unit.

When the resistance between the ground terminals is lower than 0.1Ω , it is not necessary to connect the ground cable after installing the STP pump and the STP control unit.



- ◇ When the resistance between the ground terminals is over 0.1Ω , always connect the ground cable.

Section 4 Installation of the STP Control Unit

4.1 Name and Function of Each Part

4.1.1 Front Panel

(See Figure 4.1.)

- (1) "POWER ON/OFF" Switch (illuminated alternate push button switch, green LED)
 - Press this switch to power ON/OFF the STP pump (MANUAL operation only).
 - The POWER ON/OFF built-in lamp lights when the power is ON.
- (2) "MOTOR START" Switch (momentary push button switch, black)
 - Press this switch with power ON to rotate and accelerate the STP pump (MANUAL operation only).
 - The "ACCELERATION" lamp lights simultaneously.
- (3) "MOTOR STOP" Switch (momentary push button switch, red)
 - Press this switch to decelerate and stop the STP pump (MANUAL operation only).
 - The "NORMAL OPERATION" lamp or the "ACCELERATION" lamp goes out and the "BRAKE" lamp lights simultaneously. When the number of rotations is less than approx. 2000 rpm while the STP pump is accelerating, the "BRAKE" lamp does not light.
- (4) "HEATING ON/OFF" Switch (illuminated alternate push button switch, green LED)
 - Press this switch to control the power supplied to the baking (MANUAL operation only).
 - While the power is being supplied to the baking heater, the "HEATING ON/OFF" switch built-in lamp lights.
 - Functions only under the NORMAL OPERATION state (for details, see Section 8, "Remote Input/Output Signal Terminal Blocks").
- (5) "NORMAL OPERATION" Lamp (green LED)
 - Lights during rated operation (NORMAL OPERATION state).
- (6) "ACCELERATION" Lamp (green LED)
 - Lights during acceleration (ACCELERATION state).
- (7) "BRAKE" Lamp (yellow LED)
 - Lights during braking (BRAKE state).

- (8) "OVER TEMPERATURE" Lamp (red LED)
 - Lights when any of the following abnormalities occurs:
 - a) When the motor or electromagnet overheats (110 °C or higher).
 - b) When the STP connection cable is not connected.

- (9) "BATTERY OPERATION" Lamp (red LED)
 - Lights while the power is being supplied from the battery to the STP pump during a power failure.

- (10) "FAILURE" Lamp (red LED)
 - Lights when any of the following abnormalities occurs:
 - a) When the inside of the STP control unit overheats (90 °C or more inside the heat sink).
 - b) When the motor or electromagnet overheats (110 °C or more).
 - c) When an abnormality occurs inside the inverter (overload, overspeed).
 - d) When the battery is thoroughly worn out and cannot be charged.
 - e) When the STP connection cable is not connected.

- (11) "EMERGENCY OPERATION" Lamp (red LED)
 - Lights when any of the following abnormalities occurs:
 - a) When a power failure occurs.
 - b) When continuous vibration impact is applied to the rotor causing it to come into contact with the touch down bearing.
 - c) When the STP connection cable is not connected.

For details concerning lamps (8) to (11) and abnormalities, see Section 6. "Safety Functions When an Abnormality/Error Occurs" and Section 15. "Troubleshooting."

- (12) ROTATION Meter (tachometer)
 - Indicates the number of rotations (rpm).
 - The needle moves to the black with an increase in rpm.
 - The needle moves to the red with a decrease in rpm.
 - The needle is located in the black during the rated operation.

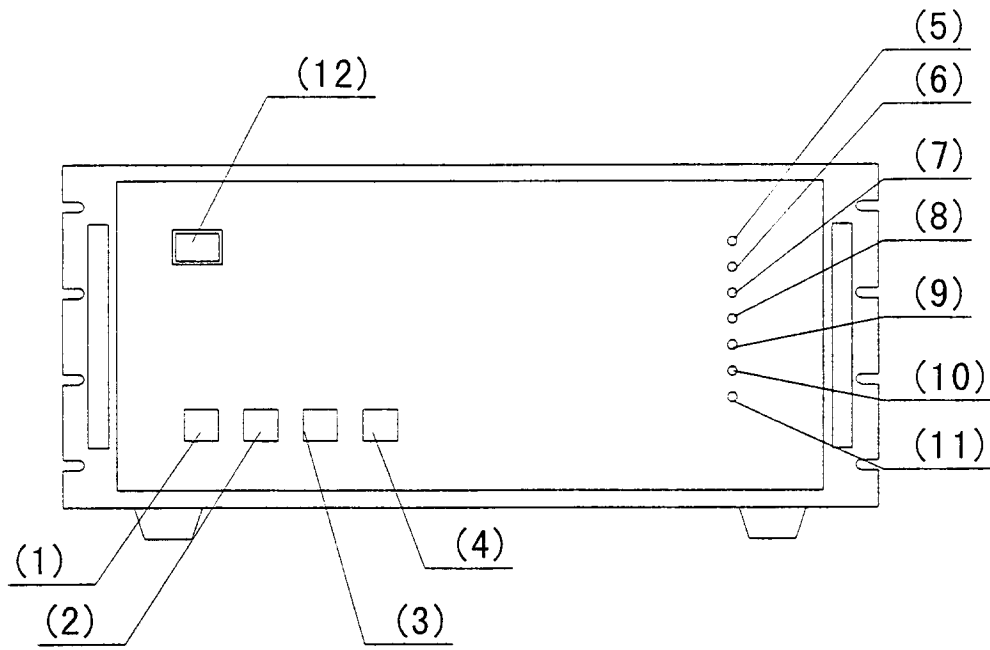

Figure 4.1 STP Control Unit Front Panel

4.1.2 Rear Panel

(See Figure 4.2.)

- (13) AC POWER Terminal Block (TB1)
 - For primary power input.

- (14) MAIN POWER Breaker
 - Switches ON/OFF the primary power.
 - A metal fitting is attached to secure the breaker at the OFF position.

- (15) P. CONNECTOR (CON5A)
 - For connection of the STP connection cable.

- (16) INVERTER OUTPUT Connector (CON2)
 - For connection of the motor connection cable.

- (17) LEAK VALVE Connector (CON8A)
 - For connection of the emergency vent. valve cable.

- (18) Ground Terminal
 - For connection of the ground cable between the STP pump and the STP control unit.

- (19) I/O TB2 Terminal Block
- (20) DC I/O TB3 Terminal Block
- (21) START STOP TB5 Terminal Block
- (22) START/STOP TB6 Terminal Block
 - For remote control.

For details concerning remote control terminal blocks (19) to (22), see Section 8, "Remote Input/Output Signal Terminal Blocks."

- (23) "MANUAL/REMOTE" Changeover Switch
 - When setting to MANUAL, only start, stop or other operations can be performed with the switches on the STP control front panel.
 - When setting to REMOTE, only start, stop or other operations can be performed by inputting the remote signal.
- (24) EXT. BATTERY (CON9) Connector
 - For connection of an external battery.



- ◇ When using EXT. BATTERY (CON9) connector, always disconnect the internal battery connector (see Section 10, "External Battery" for details).

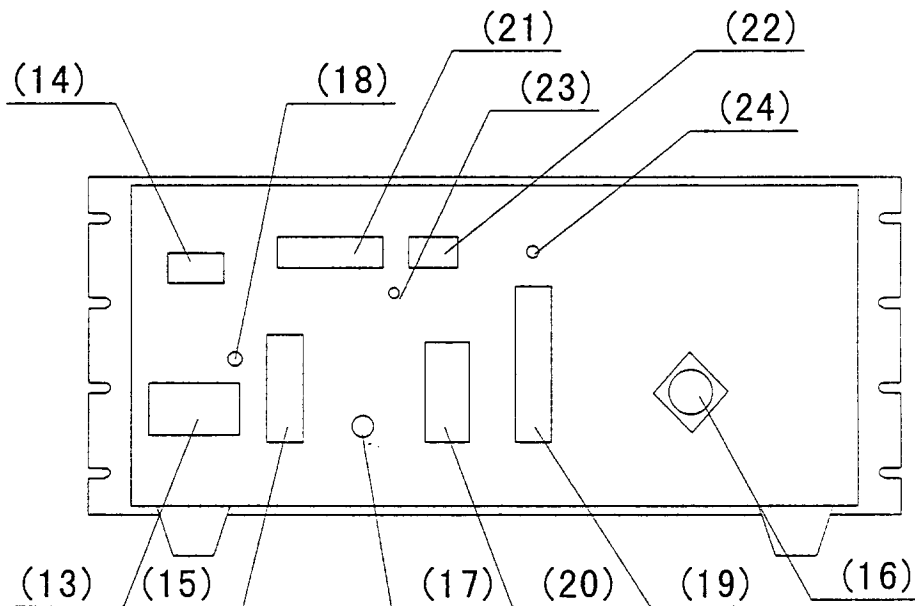

Figure 4.2 STP Control Unit Rear Panel

4.1.3 Inside of the STP Control Unit

(See Figure 4.3.)

(25) Inverter

- This is a three-phase transistor-inverter which starts/stops the STP pump.

(26) Fuses 3 to 9, 11, and 12

- These fuses protect as follows:

F3 and 4	: 250 V, 5 A (for control power protection)
F5 to 7	: 250 V, 10 A, arc-extinguishing fuses (for I/O TB2 terminal block power optional drive protection)
F8 and 9	: 250 V, 10 A, arc-extinguishing fuses (for internal and external batteries protection)
F11 and 12	: 250 V, 0.1 A (for START/STOP TB6 terminal block protection)

(27) Control Circuit Boards

- For control of the magnetic bearing, motor, safety functions, etc.

(28) Internal Battery

- For backup during a power failure.

(29) Internal Battery Connector

- For connection of internal battery (when using an internal battery, connect it to this connector).
- The internal battery has been installed upon shipment of the STP control unit so that the customer can use it (the internal battery connector is connected to the internal battery).



- ◇ **When using an external battery, disconnect internal battery connector, then connect external battery connector (see Section 10, "External Battery" for details).**

- (30) Air Cooling Fan
 - For cooling the inside of the STP control unit.
- (31) "BATTERY NG" Lamp
 - Lights when the battery capacity reduces to the minimum level (see Section 9.4, "Battery Capacity Low Warning (BATTERY NG) Lamp").
- (32) "Reset" Switch
 - Resets the state of inability to start the STP control unit due to a decrease in the battery capacity (See Section 9.4, "Battery Capacity Low Warning (BATTERY NG) Lamp").

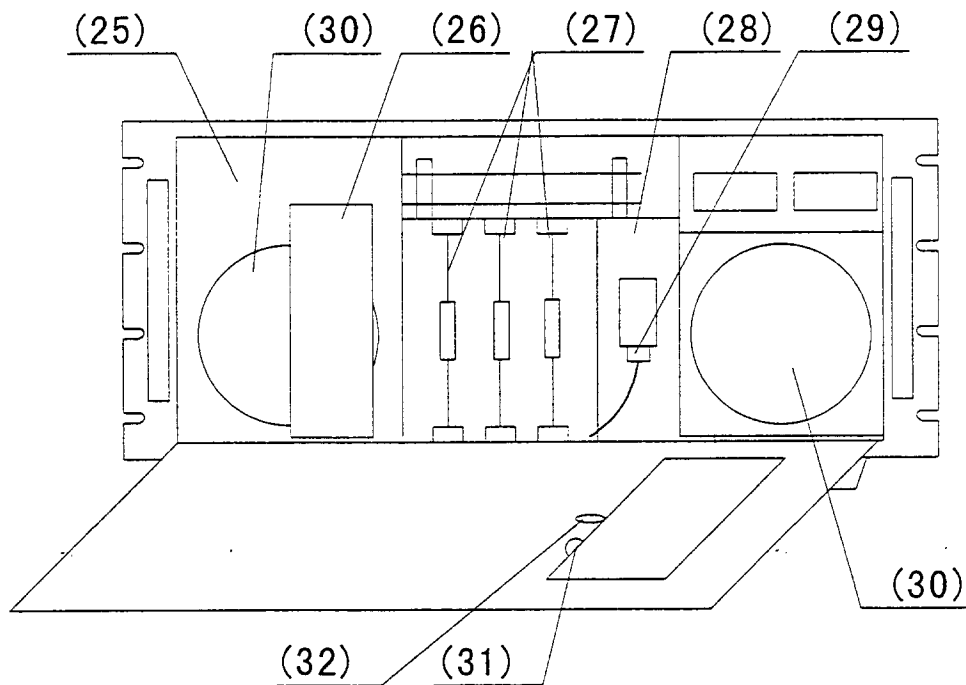

Figure 4.3 Inside of the STP Control Unit

4.2 Precautions Before Installation

4.2.1 Operating Environment

Install the STP control unit in a place meeting the following requirements:

Ambient Temperature	0 °C to 40 °C
Ambient Relative Humidity	30 to 95% (no dew condensing)
Environment	<ul style="list-style-type: none"> • A place free of exposure to direct sunlight. • A place free of high humidity. • A place free of dust. • A place free of salty air. • A place free of dripping water. • A place free of explosive or inflammable gas. • A place free of corrosive gas. • A place free of radiation. • A place free of strong magnetic and electric fields. • A place free of excessive vibration. • A place free of a source of electric noise.
Installation Condition	<ul style="list-style-type: none"> • Install the STP control unit horizontally (within $\pm 10^\circ$).

4.2.2 Installation Area

Leave enough space for the following in addition to that for the STP control unit (see Figure 4.4, "Peripheral Space of the STP Control Unit.")

- Space for maintenance and inspection
- Space for inlet and outlet of air for cooling
 - Top and side: 5 cm or more
 - Bottom: 2.4 cm or more (height of the rubber foot)
- Space for connecting the cables
 - Rear: 15 cm or more



- ◇ The minimum bending radius of the STP connection cable is 150 mm (see Figure 16.2, "External Appearance of the STP Control Unit" [Cable Space]).
DO NOT excessively bend the cables and beware of any obstacles when installing the STP pump.
Also, leave enough space to install other cables without bending them excessively.

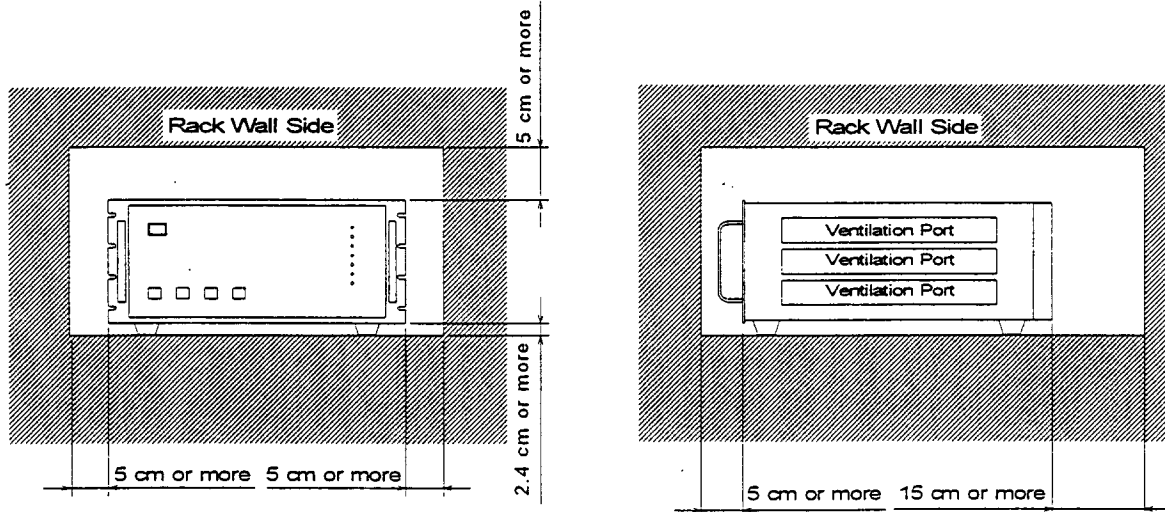

Figure 4.4 Peripheral Space of the STP Control Unit

4.3 Attaching the STP Control Unit Front Panel to a Rack

The dimensions of the STP control unit front panel conform to JIS. Therefore, this panel can be attached to any type of commercially-available racks.

Attach the front panel unit to the rack according to the following steps:

1) When attaching the front panel to a rack:

- Attach the front panel to a rack using the screw holes for the front panel.
- Also support the STP control unit from the bottom using a support angle or a similar tool.

2) When attaching the front panel to a movable rack:

- Attach the front panel to a movable rack using the screw holes for the front panel.
- To protect the STP control unit during transport, remove the rubber foot from the bottom and attach the STP control unit to the rack using the screw holes for the rubber foot.



- ◇ The STP control unit cannot be supported with only the screws on the front panel (the STP control unit is a heavy product). Always support it from the bottom. DO NOT block the ventilation port.
- ◇ For the peripheral space of the STP control unit, see Figure 4.4, "Peripheral Space of the STP Control Unit."



- ◇ For the dimensions of the front panel and positions of screw holes for the rubber foot, see Figure 16.2, "External Appearance of the STP Control Unit."

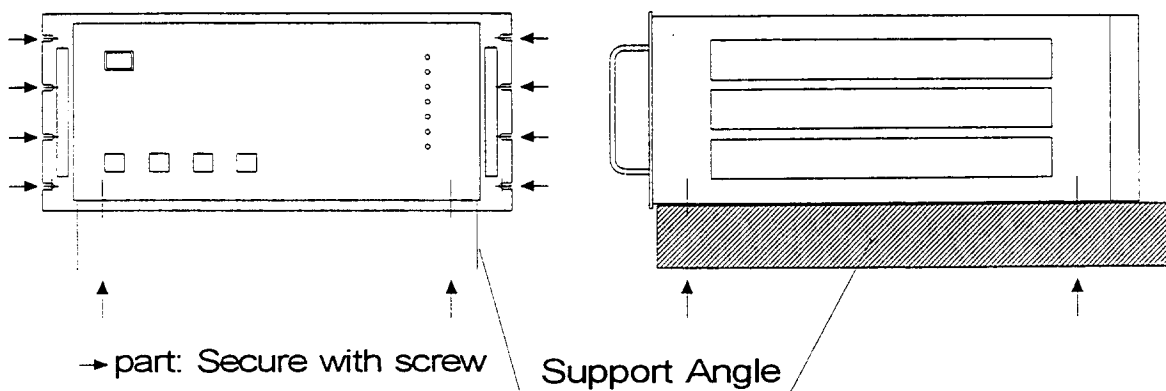

Figure 4.5 Example of Securing the STP Control Unit

4.4 Cable Connection

4.4.1 Name and Dimensions of Each Cable

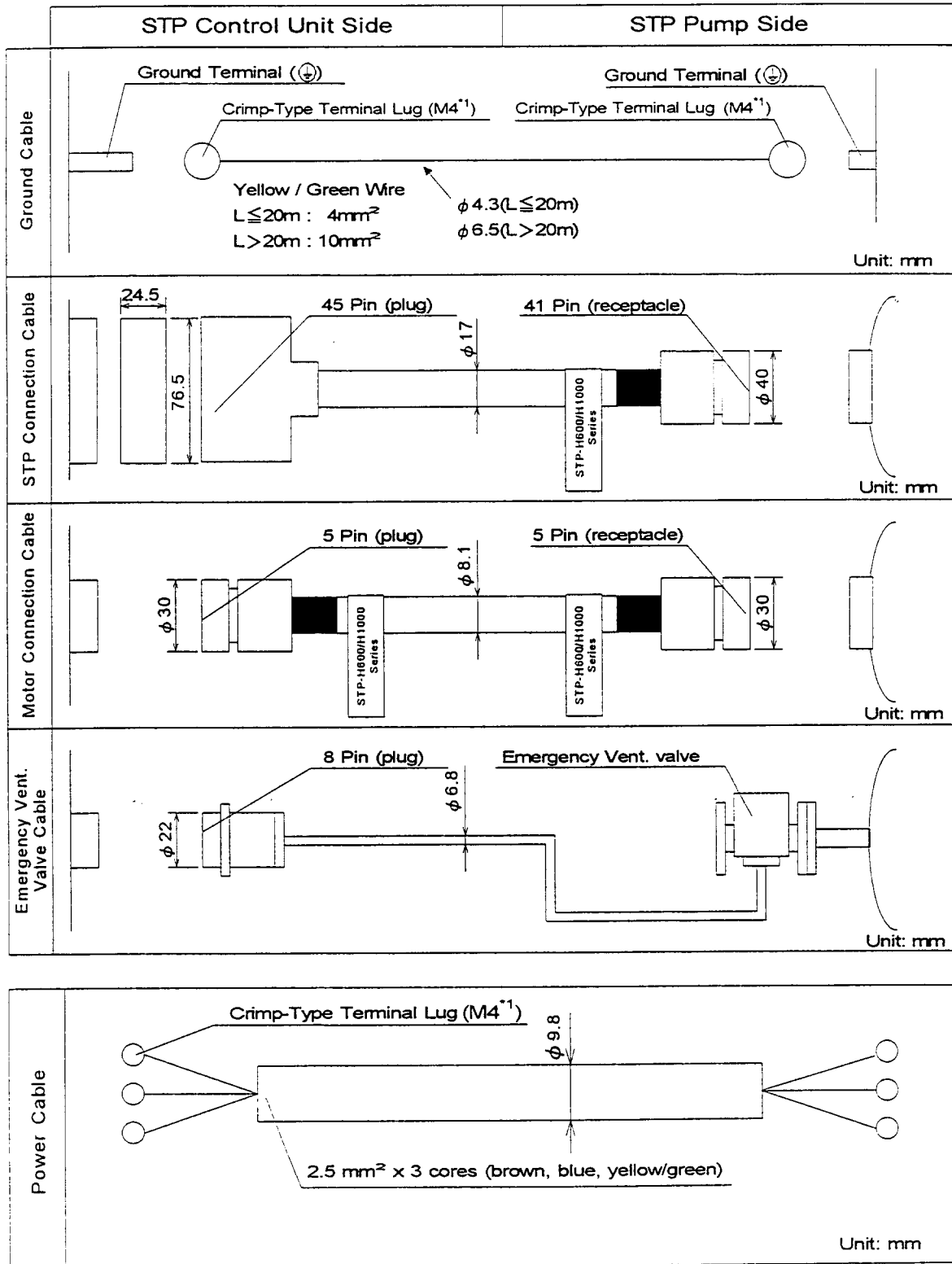

Figure 4.6 External Dimensions of Each Cable

*1: JIS

4.4.2 How to Connect the Cables



- ◇ When connecting/disconnecting cables, always power OFF the STP pump (switch the breaker "OFF").
Failure to do so may result in electric shock or product damage.
- ◇ With each connector, align the position of the guide key and insert the pin vertically so as not to bend it.
If the pin is bent, not only may the connector not function normally, but may the pin make contact, resulting in a malfunction.
- ◇ Lock and securely tighten each connector and screw.
- ◇ DO NOT apply voltage to each pin and DO NOT cause any short-circuiting between pins.
- ◇ Connect each cable securely. DO NOT place heavy objects on the cables nor bend them excessively.
Support each cable so as not to apply direct force to the connectors or terminals.
If any problem occurs in cables, connectors or terminals, the STP pump may not function normally.

1) Connecting Ground Cable

Connect the ground cable (yellow/green) between the ground terminal of the STP pump and the ground terminal of the STP control unit.

When the resistance between the ground terminals is lower than 0.1 Ω , it is not necessary to connect the ground cable after installing the STP pump and the STP control unit.



- ◇ First, connect the ground cable. Next, connect other cables.
- ◇ When the resistance between the ground terminals is over 0.1 Ω , always connect the ground cable. Failure to do so may result in electric shock.

2) Connecting the STP Connection Cable

Connect the female side of the STP connection cable to the STP connector of the STP pump and connect the male side to "P.CONNECTOR CON5A" of the STP control unit.



- ◇ Always use the STP pump, STP control unit and the STP connection cables of the same model name, serial number and cable length. Failure to do so may result in product damage. Contact your nearest Seiko Seiki representative if you plan to use units with the same model name but different serial numbers and cable length; They must be adjusted. In some cases, the configuration may need more adjustment.
- ◇ Use the STP connection cable that has a label affixed

<p style="text-align: center;">STP-H600/H1000 Series</p>
--

The use of different cables may result in product damage.

3) Connecting the Motor Connection Cable

Connect the female side of the motor connection cable to the motor connector of the STP pump and connect the male side to "INVERTER OUTPUT CON2" of the STP control unit.



- ◇ Use the motor connection cable that has a label affixed

<p style="text-align: center;">STP-H600/H1000 Series</p>
--

The use of different cables may result in product damage.

4) Connecting the Emergency Vent. Valve Cable

Connect the emergency vent. valve to the purge port of the STP pump and the connector to "LEAK VALVE CON8A" of the STP control unit (see Section 3.3.5. "Connecting the Emergency Vent. Valve").

5) Connecting Primary Power (Primary Side) Cable

Connect power cable to the "AC POWER TB1" on the STP control unit rear panel as shown in Table 4.1.

Table 4.1 Connecting Primary Power Cable

TB1 Pin No.	Cable Color	Remarks
1 (L)	Brown	Single phase 200 to 240 V AC \pm 10% Both 50/60 Hz
2 (N)	Blue	
3 (PE)	Yellow/Green	Ground

Secure primary power cable to the STP control unit rear panel using the cable fitting tool (see Figure 4.7).



- ◇ Connect the primary power cable securely to prevent incorrect wiring.
- ◇ DO NOT apply surge voltage exceeding 1 kV to the input power line.
- ◇ Always ground primary power cable to prevent electric shock.
- ◇ DO NOT remove the ground cable attached to the terminal block cover.

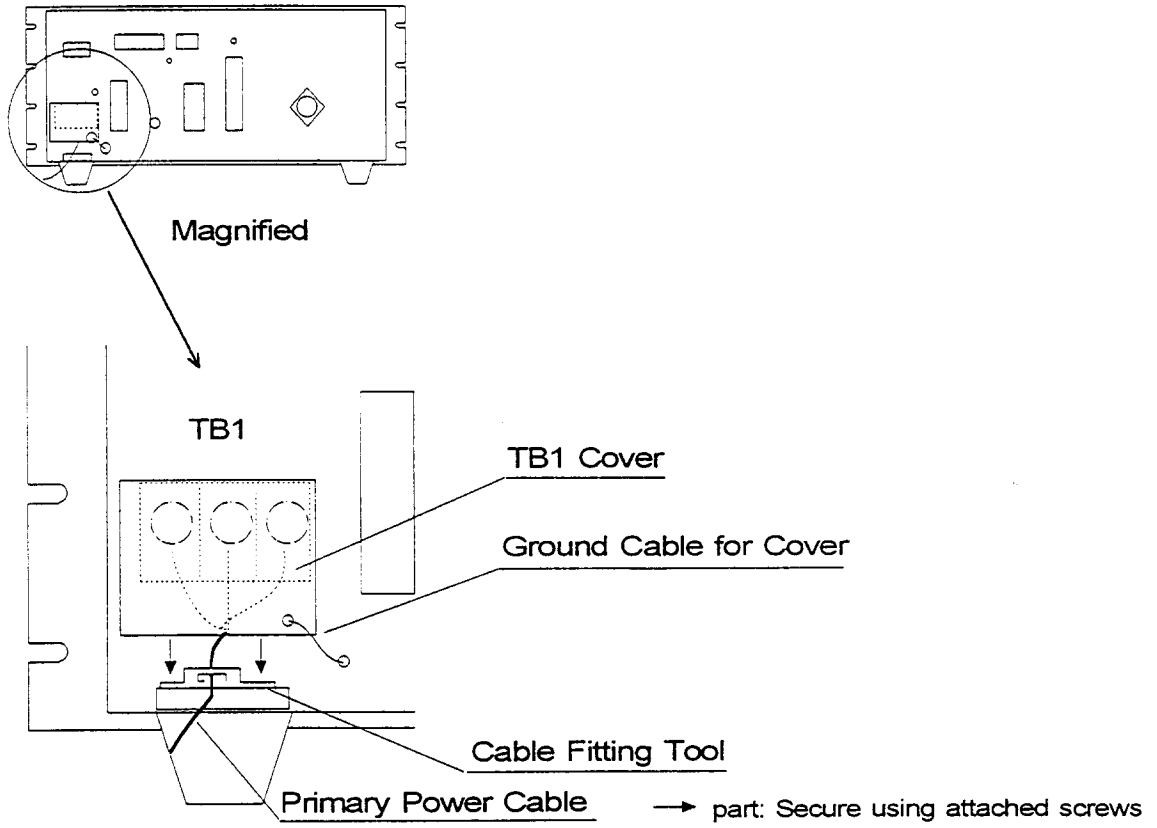

Figure 4.7 How to Secure Primary Power Cable

Section 5 How to Start/Stop the STP Pump



- ◇ NEVER connect or disconnect any cables while the power is ON.
- ◇ NEVER turn the primary power OFF (switch the breaker "OFF") while the STP pump is in rotation.
- ◇ DO NOT release the inlet port flange or outlet port flange into the atmosphere while the STP pump is in rotation.

5.1 Before Starting

After completing installation, piping, leakage test of the STP pump and installation of the STP control unit, the STP pump is ready for start.

Check the following items before starting:

- 1) Are the STP pump and the STP control unit secured according to the appropriate method?
- 2) Is the primary power cable connected correctly to the power supply?
- 3) Is the power voltage selected properly?
- 4) Do the manufacturing No. and the cable length of the STP pump, the STP control unit and the STP connection cable match?
- 5) Are the labels affixed correctly to the STP connection cable and the motor connection cable?

STP-H600/H1000
Series
- 6) Are the ground cable, the STP connection cable, the motor connection cable, and the emergency vent. valve cable securely connected?
Is the connection cable securely connected?
Are each terminal and each connector securely locked?

5.2 Starting/Stopping Time

Starting time: Approx. 6 minutes after start operation.

Stopping time: Approx. 6 minutes after stop operation.

If the rotational speed does not attain the rated speed within about 15 minutes, the "FAILURE" lamp lights. Before restarting the STP pump, always check whether or not there is leakage from the piping or the vacuum equipment and also confirm the capacity and the START state of the auxiliary pump.



- ◇ When start/stop operations are frequently performed, the STP pump may overheat. Avoid doing so.

5.3 Start Procedures

Start the auxiliary pump before or simultaneously with start of the STP pump. Open the vacuum valve located at the outlet port flange side after starting the auxiliary pump.



- ◇ **DO NOT** open the vacuum valve without operating the auxiliary pump.
Doing so may cause a reverse flow of oil, which could contaminate the inside of the STP pump.

5.4 Stop Procedures

Close the vacuum valve located at the outlet port flange side just before or after stopping the STP pump.

After closing the valve, stop the auxiliary pump.



- ◇ **DO NOT** stop the auxiliary pump without closing the vacuum valve. Depending upon the type of the auxiliary pump, doing so could cause a reverse flow of atmospheric air into the STP pump, which may result in a malfunction.



- ◇ **DO NOT** stop the auxiliary pump without closing the valve. Doing so may cause a reverse flow of oil, which could contaminate the inside of the STP pump.