

**There are two methods of operating the STP pump: MANUAL and REMOTE.**

**Select one which fits your vacuum equipment.**

### **5.5 Manual Operation**

Slide the "MANUAL/REMOTE" changeover switch on the rear panel to "MANUAL."

#### **5.5.1 Powering ON**

- 1) Switch ON the breaker on the rear panel (to prevent incorrect operation, a metal fitting is attached to the breaker. Loosen the screw, lift the metal fitting and secure it).
- 2) Press the "POWER ON/OFF" switch (the switch is thoroughly locked down). The magnetic bearing functions and the rotor levitates (POWER ON state). The "POWER ON/OFF" switch built-in lamp lights.

#### **5.5.2 Starting the STP Pump**

- 1) Press the "MOTOR START" switch on the front panel after powering ON to start and accelerate the STP pump.  
The "ACCELERATION" lamp lights (ACCELERATION state).
- 2) When the STP pump attains the rated speed of rotations, the "ACCELERATION" lamp goes out, and the "NORMAL OPERATION" lamp lights (NORMAL OPERATION state).

#### **5.5.3 Stopping the STP Pump**

- 1) Press the "MOTOR STOP" switch on the front panel to stop the STP pump. The STP pump starts to decelerate and stop.  
The "NORMAL OPERATION" lamp or the "ACCELERATION" lamp goes out, and the "BRAKE" lamp lights (BRAKE state)  
(when the number of rotations is less than approx. 2000 rpm while the STP pump is accelerating, the "BRAKE" lamp does not light).
- 2) The "BRAKE" lamp goes out when the number of rotations slows down to approx. 1000 rpm.

#### **5.5.4 Starting the STP Pump after Stopping**

Press the "MOTOR START" switch on the front panel to reaccelerate the STP pump.

The STP pump can be reaccelerated even while the STP pump is stopping.

#### **5.5.5 Powering OFF**

- 1) When all of the "ACCELERATION," "NORMAL OPERATION" and "BRAKE" lamps are off:

Press the "POWER ON/OFF" switch. The switch pops up into the unlocked position, the magnetic bearing stops, and the rotor lands (POWER OFF state).

The "POWER ON/OFF" switch built-in lamp goes out.

- 2) When one of the "ACCELERATION," "NORMAL OPERATION" and "BRAKE" lamps is lit:

- i. Even when the "POWER ON/OFF" switch is OFF, the rotor will not land. Also, operation of the STP pump remains unchanged.

The "POWER ON/OFF" switch built-in lamp remains lit.

- ii. When the STP pump stops under the above state, the magnetic bearing stops, and the rotor automatically lands at the time the "BRAKE" lamp goes out.



#### **NOTICE**

- ◇ The brake of the STP pump disengages at approx. 1000 rpm and the "BRAKE" lamp goes out. The STP pump rotates by inertia even after the "BRAKE" lamp has gone out. Powering OFF immediately after the "BRAKE" lamp goes out or while any lamp of the "ACCELERATION," "NORMAL OPERATION," or "BRAKE" lamp is being lit causes the touch down bearing to touch the rotor resulting in a noise. Frequent POWER OFF operations will expedite the wear of the touch down bearing. It is recommended to power OFF the STP pump after it stops thoroughly.

**5.6 Remote Operation**

(Read through Section 8. "Remote Input/Output Signal Terminal Blocks" before use.)

Slide the "MANUAL/REMOTE" changeover switch on the STP control unit rear panel to "REMOTE."

**5.6.1 Powering ON**

Switch ON the breaker on the STP control unit rear panel, (to prevent incorrect operation, a metal fitting is attached to the breaker. Loosen the screw, lift the metal fitting and secure it ).  
The magnetic bearing functions and the rotor levitates (POWER ON state).  
The "POWER ON/OFF" switch built-in lamp lights.

**5.6.2 Starting/Stopping the STP Pump**

There are three methods of starting/stopping the STP pump. Use one of them.

Table 5.1 Starting/Stopping the STP Pump During Remote Operation

Method	Terminal Block	Starting the Pump	Stopping the Pump
1	TB5	1) Short the circuit between <u>③ - ②</u> (STOP IN). 2) Short the circuit between <u>② - ①</u> (START IN) for 0.3 seconds or more. However, when inputting the signal simultaneously with switching <u>ON</u> the breaker on the rear panel, continue to short the circuit for 5 seconds or more.	Open the circuit between <u>③ - ②</u> (STOP IN).
2	TB5	Short the circuit between <u>① - ③</u> (START/STOP IN).	Open the circuit between <u>③ - ①</u> (START/STOP IN).
3	TB6	Input 25 to 250 V AC or 24 to 48 V DC between <u>② - ①</u> (START/STOP IN). With DC, the (+) side can be connected to either <u>②</u> or <u>①</u> .	Open the circuit between <u>② - ①</u> (START/STOP IN).

### **5.6.3 Starting the STP Pump After Stopping**

Perform the rotation procedures to reaccelerate the STP pump. See Section 5.6.2, "Starting/Stopping the STP Pump."

The STP pump can be reaccelerated even while the STP pump is stopping.

### **5.6.4 Powering OFF**

When all three ("ACCELERATION", "NORMAL OPERATION" and "BRAKE") lamps are off, switch the breaker OFF on the rear panel. The magnetic bearing stops, and the rotor lands. The POWER ON/OFF switch built-in lamp goes out.



- ◇ NEVER switch OFF the breaker on the rear panel while any of the "ACCELERATION," "NORMAL OPERATION" and "BRAKE" lamps is being lit.  
If doing so under the above condition, the STP pump may react as if there was a power failure.



- ◇ The brake of the STP pump disengages at approx. 1000 rpm and the "BRAKE" lamp goes out. The STP pump rotates by inertia even after the "BRAKE" lamp has gone out. Powering OFF immediately after the "BRAKE" lamp goes out causes the touch down bearing to touch the rotor resulting in a noise. Frequent POWER OFF operations may expedite the wear of the touch down bearing. It is recommended to power OFF the STP pump after it stops thoroughly.

## Section 6 Safety Functions When an Abnormality/Error Occurs

The STP pump is provided with safety functions for various abnormalities/errors (See Tables 6.3 and 6.4, "Safety Functions").

For troubleshooting, see Section 6.2, "Restarting After Any Safely Function Operates" and Section 15, "Troubleshooting."

### 6.1 Safety Functions

#### 6.1.1 Power Failure

<Operation at a Power Failure>

When power voltage drops below 170 V due to a power failure, internal battery of the STP control unit automatically activate to supply power to the STP pump in order to maintain normal function of the magnetic bearing (backup operation during a power failure).

- 1) The STP control unit detects any power failure of 2 seconds or more and automatically switches to the BATTERY OPERATION mode and the STP pump decelerates. Gases are introduced from the emergency vent. valve at approx. 7000 rpm and the rotor lands on the touch down bearing and stops at approx. 2000 rpm.

In the BATTERY OPERATION mode, the "BATTERY OPERATION" lamp and the "EMERGENCY OPERATION" lamp light, and an alarm signal is output from I/O TB2 ALARM OUT terminals ⑩ - ⑨, ⑩ - ⑪ regardless of MANUAL or REMOTE OPERATION mode.

When the rotor lands on the touch down bearing, the "BATTERY OPERATION" lamp and the "EMERGENCY OPERATION" lamp go out, and the alarm output is reset.

- 2) In case of a power failure of less than 2 seconds, the STP control unit does not detect it and the STP pump continues rotating.

<Operation after a Power Recovery>

1) MANUAL Operation

The STP pump continues decelerating even after a power recovery.  
Press the "START" switch to reaccelerate the STP pump.

2) REMOTE Operation

- When the START signal is input to the REMOTE input terminal at a power recovery to reaccelerate the STP pump.
- When the START signal is not input to the REMOTE input terminal after the power recovery, the STP pump continues the BRAKE operation.



- ◇ Establish a sequence so that power can be supplied to the STP control unit immediately after a power recovery.

Table 6.1 shows the states of lamps and the REMOTE output signal at a power failure.

Also, Table 6.2 shows operations of the STP pump after a power recovery.

Table 6.1 State of Lamps and REMOTE Output Signal at Power Failure

Power failure time	Number of rotations (rpm)	LED lamps	REMOTE output signal (I/O TB2)	
		"BATTERY OPERATION" "EMERGENCY OPERATION"	Power ON signal	ALARM signal
Approx. 2 sec. or more	Less than 2000	Lights	ON	ON
	2000 or less	Goes out	OFF	OFF
Less than approx. 2 sec.	Does not detect power failure.			

Table 6.2 Operation of the STP Pump after Power Recovery

Power failure time	MANUAL operation	REMOTE operation	
	STP pump operation after power recovery	"START" REMOTE signal input after power recovery	STP pump operation after power recovery
Approx. 2 sec. or more	Deceleration/Stop	Yes	Reacceleration
		No	Deceleration/Stop
Less than approx. 2 sec.	Continues as before.		

### **6.1.2 Abnormal State of Magnetic Bearing**

When the magnetic bearing does not function normally due to a breakage of the STP connection cable, disconnection of connectors or any abnormality/error of the STP control circuit, the rotor falls on the touch down bearing.

Simultaneously, the emergency vent. valve is opened to introduce gases and the STP pump stops, and the "EMERGENCY OPERATION" lamp lights.



- ◇ When an abnormality/error occurs in the magnetic bearing, check the STP pump as well as the STP control unit, and contact Seiko Seiki.

### **6.1.3 Excessive Vibration**

When serious vibration or mechanical shock causes the rotor to touch the touch down bearing (due to external vibration/impact, intrusion of atmosphere or foreign materials into the STP pump or rotor imbalance), the emergency vent. valve is opened to introduce gases, the STP pump stops, and the "EMERGENCY OPERATION" lamp lights.

### **6.1.4 Inverter Overload**

When the STP pump does not attain the rated speed within about 15 minutes after starting or when the ACCELERATION state remains unchanged during operation for about 15 minutes, the inverter stops and the STP pump continues rotating by inertia.

The "FAILURE" lamp lights.

### **6.1.5 Overheating Inside the STP pump**

When the temperature of the motor inside the STP pump exceeds 110 °C due to an abnormal baking temperature or overload operation, the STP pump enters the STOP operation.

The "OVER TEMPERATURE" lamp and the "FAILURE" lamp light.

### **6.1.6 Overheating Inside the STP Control Unit**

When the temperature inside the STP control unit (at the heat sink) exceeds 90 °C due to a failure in the air cooling fan, external heat source, etc., the STP pump enters the STOP operation.

The "FAILURE" lamp lights.

### **6.1.7 Overspeed**

When the rotational speed of the STP pump exceeds 37,500 rpm due to a failure in the inverter, the STP pump enters the STOP operation.

The "FAILURE" lamp lights.

### **6.1.8 Abnormal Battery Voltage**

When the battery voltage is 42 V DC or less due to deterioration in the battery or incorrect connection while the power is ON, the STP pump does not rotate even if the STP pump START operation is performed.

The "FAILURE" lamp lights (Both the "EMERGENCY OPERATION" lamp and the "BATTERY NG" lamp inside the STP control unit front panel may light).



- ◇ **NEVER disconnect the internal or external battery connection cable while the STP pump is under POWER ON state.**



- ◇ **When the "BATTERY NG" lamp inside the STP pump front panel comes on, "FAILURE" and "EMERGENCY OPERATION" lamps also come on.  
When the power is turned on again, the "FAILURE" lamp goes out, while the "BATTERY NG" and "EMERGENCY OPERATION" lamps still remain lit.**

### **6.1.9 Failure of Brake**

If the brake is broken, the emergency vent. valve is opened to force the STP pump to stop.

## **6.2 Restarting after Any Safety Function Operates**

### **1) In case of a power failure:**

Establish a sequence so that power can be supplied to the STP control unit immediately after a power recovery.

### **2) In case the "FAILURE" lamp lights due to an overload of the inverter (the STP pump continues rotating by inertia: [FREE RUN state]):**

#### **<MANUAL OPERATION>**

- i. Press the "MOTOR STOP" switch. The "FAILURE" lamp goes out and the FREE RUN state is reset.
- ii. Press the "MOTOR START" switch and press the "MOTOR STOP" switch again. The brake functions and the STP pump decelerates.
- iii. After the STP pump stops thoroughly (the "BRAKE" lamp goes out: the needle of the tachometer is in the red), turn "OFF" the "POWER ON/OFF" switch, switch the breaker "OFF," and remove probable causes of the abnormality/error.
- iv. Restart the STP pump and check if it operates correctly.

#### **<REMOTE OPERATION>**

- i. Slide the "MANUAL/REMOTE" changeover switch on the rear panel to "MANUAL."
- ii. Press the "MOTOR STOP" switch. The "FAILURE" lamp goes out and the FREE RUN state is reset.
- iii. Press the "MOTOR START" switch and press the "MOTOR STOP" switch again. The brake functions and the STP pump decelerates.
- iv. After the STP pump stops thoroughly (the "BRAKE" lamp goes out: the needle of the tachometer is in the red) , switch the breaker "OFF," and remove probable causes of the abnormality/error.
- v. Restart the STP pump and check if it operates correctly.

**In case the FREE RUN state is not reset after troubleshooting:**

- i. Check the tachometer on the front panel.
- ii. If the needle is in the red, it means the STP pump has stopped.  
Power OFF and switch the breaker "OFF."
- iii. If the needle is in the black, the STP pump is rotating.  
Wait for it to enter the red. Then, power OFF and switch the breaker "OFF."
- iv. Restart the STP pump and check if operates correctly.



- ◇ DO NOT power OFF and switch the breaker OFF until the needle is in the red.



- ◇ If the FREE RUN state cannot be reset, it takes about 8 to 10 hours to stop the STP pump (the needle is in the red) because it rotates by inertia.  
To stop the STP pump quickly, close the vacuum valve at the outlet port flange and introduce gas from the purge port into the STP pump.

**3) Other Cases**

After the STP pump stops thoroughly, power OFF, switch the breaker "OFF" and remove the cause of the abnormality/error. Then, restart the STP pump and check if it operates correctly.



- ◇ For probable causes and troubleshooting, See Section 15, "Troubleshooting."

### **6.3 Operation of the Emergency Vent. Valve**

The emergency vent. valve is opened immediately after an abnormality/error in the magnetic bearing, excessive vibration or any other abnormality/error is found. Gases (dry N<sub>2</sub> gases or atmospheric air) are introduced through the emergency vent. valve into the STP pump.

Attach the emergency vent. valve taking care of the following NOTICE:



- ◇ It is recommended to introduce dry N<sub>2</sub> gases to prevent the STP pump and vacuum equipment from getting contaminated. The pressure for introducing gas ranges from zero (atmospheric pressure) to 0.5 kgf/cm<sup>2</sup> (gauge pressure).
- ◇ The rotor comes into contact with the touch down bearing, with the emergency vent. valve opened. This may damage the rotor or the touch down bearing.  
To stop the STP pump in a very short time, design an appropriate vacuum exhaust system that closes the vacuum valve at the outlet port flange when the emergency vent. valve is opened. This prevents the rotor and the touch down bearing from being damaged.
- ◇ The state of the emergency vent. valve can be checked using "DC I/O TB3 L. VALVE N. O. OUT Terminal ⑨—⑩."

Table 6.3 Safety Functions (1/2)

[E. V. used herein is the abbreviation for Emergency Vent.]					
Abnormality /Error	Operation state of safety functions	Lamp indication	REMOTE output signal	State of the STP pump	Probable causes of an abnormality/error
Power failure	Failure time: 2 seconds or more (for details, refer to Section 6.1.1, "Power Failure").	"BATTERY OPERATION" "EMERGENCY OPERATION"	"ALARM" "E. V. valve OPEN signal"	Levitation continues by battery. The STP pump stops. The E. V. valve functions at approx. 7000 rpm. The rotor lands on the touch down bearing at approx. 2000 rpm.	Power failure. Power cable breakage. Power cable disconnection
Abnormal magnetic bearing	Rotor descends onto the touch down bearing.	"EMERGENCY OPERATION"	"ALARM" "E. V. valve OPEN signal"	The E. V. valve is opened. The STP pump stops.	STP connection cable breakage. STP connection cable disconnection. Abnormal control circuit.
Excessive vibration	Rotor vibration: 100 $\mu$ m p-p or more.	"EMERGENCY OPERATION"	"ALARM" "E. V. valve OPEN signal"	The E. V. valve is opened. The STP pump stops.	External vibration, and impact. Intrusion of atmospheric air. Intrusion of foreign materials.
Overload of inverter	Current of more than 40A flows into the inverter momentarily or current of more than 11.5A flows into the inverter continuously for 15 minutes.	"FAILURE"	"ALARM"	The inverter stops. The STP pump continues to rotate by inertia.	Leakage from the vacuum equipment or piping. Insufficient pressure at inlet and outlet port sides. Failure of starting of the auxiliary pump.

Table 6. 4 Safety Functions (2/2)

Abnormality /Error	Operation state of safety functions	Lamp indication	REMOTE output signal	State of the STP pump	Probable causes of an abnormality/error
Overheating inside the STP pump	Temperature of the STP pump motor: 110 °C or more	"OVER TEMPERATURE" "FAILURE"	"ALARM"	The STP pump stops.	Abnormal baking temperature. Insufficient cooling. Leakage of vacuum equipment or piping. Continuous repetition of startup/shutdown. Extraordinarily-high temperature.
Overheating inside the STP control unit	90°C or more in the STP control unit and heat sink.	"FAILURE"	"ALARM"	The STP pump stops.	Failure in the cooling fan. Shielding of cooling air inlet and ventilation port. Extraordinarily-high temperature
Overspeed	Rotational speed of the STP pump:37,500 rpm or more.	"FAILURE"	"ALARM"	The STP pump stops.	Failure in the inverter.
Abnormal battery terminal voltage	Battery terminal voltage: 42 V or lower	"FAILURE" *1 ("EMERGENCY OPERATION" or "BATTERY NG" lamp may light)	"ALARM"	The STP pump does not start.	Incorrect connection of the battery. Deterioration in the battery.

\*1: When the power is turned on again, this lamp goes out.

## Section 7 Gas Suction, Cooling and Baking the STP Pump

### 7.1 Gas Suction



- ◇ When sucking gases, they may remain in the STP pump. Introduce a purge gas and then exhaust all gasses. Residual gases in the STP pump may cause an accident when the STP pump is removed. Confirm the characteristics of gases to be used, referring to the Material Safety Data Sheet (MSDS) you obtain from the gas supplier.



- ◇ Chlorine or fluorine system gases can be used in the chemical specific STP-H600C/H1000C (type C). When you use gases including alkaline metals, but excluding Li, gases including Ga, Hg, In, or Sn, or HBr, contact Seiko Seiki (See Section 1.1, "Usable Gases").
- ◇ NEVER use corrosive gases (chlorine, fluorine, or other system gases) in the STP-H600/STP-H1000 pump or other models without anti-corrosion treatment.
- ◇ Cool the STP pump to within the operating pressure range to prevent the STP pump from overheating when sucking gases (See Section 7.2, "Cooling the STP Pump," and Table 16.1, "Specifications for the STP Pump" [maximum working pressure/allowable backing pressure]).

### 7.1.1 How to Introduce a Purge Gas

When sucking reactive or corrosive gases, introduce a purge gas to protect the inside of the STP pump.

- 1) Connect a needle valve or a similar part to the purge port and introduce a dry N<sub>2</sub> gas or other gas to perform a gas purge (See Section 3.3.6 "Connecting the Purge Port").
- 2) The proper amount of the gas purge is approx.  $3.4 \times 10^{-2}$  Pa·m<sup>3</sup>/sec (20SCCM).  
The allowable gas pressure ranges from zero (atmospheric pressure) to 0.5 kgf/cm<sup>2</sup> (gauge pressure).



- ◇ When not using the purge port, always mount the blank flange (attached at delivery).
- ◇ High-pressure at the inlet port may result in a noise. This is no abnormality/error.

## **7.2 Cooling the STP Pump**

(See Figure 7.1.)

There are two methods for cooling: Water cooling and Air cooling.  
When sucking gases, cool the STP pump in accordance with the operating pressure range.

Also, when performing baking, always cool the STP pump.  
Select the best one which fits your vacuum equipment.

### **7.2.1 Water Cooling Method**

- 1) Connect the cooling water pipe to the cooling water port in accordance with Figure 7.1.
- 2) The female screw PT \*1 (RC)1/4 is used in the cooling water port (see Figure 16.1, "External Appearance of the STP Pump").
- 3) Use connection hose of ID (internal diameter) 8 mm, and secure it to prevent water leakage.
- 4) Use cooling water under the following conditions:
 

Amount of water:	2 liter/min.
Temperature:	5 to 25 °C
Water pressure:	3 kgf/cm <sup>2</sup> or lower.

#### **NOTICE**

- ◇ **Use clean water as much as possible.**  
Cooling water containing foreign materials may corrode or clog the cooling water pipe.  
When the cooling system is clogged with foreign materials, clogs may possibly be removed by feeding cooling water reversely.
- ◇ **When the STP pump is overheated due to shortage or suspension of water, the protective function detects the overheated condition in the STP pump and stops the STP pump.**  
As a further safety procedure, attach a flow switch to the cooling water exit so that the STP pump stops if abnormal cooling water flow occurs (a flow switch is available on the market).
- ◇ **When the STP pump is not to be used for a long period of time or it is to be moved after use, introduce compressed air from one side of the inlet/outlet port so that no water will remain inside.**
- ◇ **The joint for water cooling unit is made of brass. To prevent corrosion, connect the brass joint.**

---

\*1: JIS

### **7.2.2 Air Cooling Method**

When water cooling is not available, an air cooling unit (optional accessory) can be used. Follow the steps below:

- 1) Remove the water cooling unit (it is attached with the four M8\*1 screws).
- 2) Attach the air cooling unit using screw holes for the water cooling unit.



- ◇ Check the rated voltage of the air cooling unit before use.
- ◇ Purchase a breaker or fuses for the air cooling unit (remote terminal block TB2 incorporates fuses).
- ◇ When connecting the power for the air cooling unit (over 25 V AC) to the remote terminal block, secure the cable using the attached cable fitting tool.  
DO NOT apply excessive force to the cable for the air cooling unit.

Follow the steps below to run the STP pump associated with the air cooling unit (read through Section 8, "Remote Input/Output Signal Terminal Blocks." then operate them).

- 1) Connect the power cable of the air cooling unit between "I/O TB2 FAN OUT Terminal ⑤ - ⑥."
- 2) Input the power supply of the air cooling unit between "I/O TB2 AC. POWER IN Terminal ⑱ - ⑳."
- 3) The air cooling unit functions under the "ACCELERATION" or "NORMAL OPERATION" state.
- 4) The air cooling unit also stops when the STP pump stops.

---

\*1: JIS

### **7.3 Baking the STP Pump**

To attain a lower pressure in a shorter time and reduce the exhaust time, bake the vacuum equipment and STP pump.

#### **WARNING**

- ◇ The surfaces of the STP pump and its peripheral equipment will become extremely hot when performing baking. **NEVER** touch them with bare hands.

#### **CAUTION**

- ◇ When baking the STP pump, always cool it to prevent overheating (for the cooling method, see Section 7.2, "Cooling the STP Pump").
- ◇ Start baking after cooling is started.  
Set the temperature of the baking heater to 120 °C or lower (an optional baking heater is set to 110 °C or lower).
- ◇ **DO NOT** suck gases during baking to prevent overheating.

#### **NOTICE**

- ◇ To exhaust the gas discharged from the vacuum equipment and the inner wall of the STP pump, run the STP pump during baking.

### **7.3.1 Attaching a Baking Heater**

- 1) Attach a baking heater (optional accessory) as near as possible to the inlet port flange (see Figure 7.1, "Attaching Positions of the Cooling Unit and Baking Heater").
- 2) Affix the "Hot Surface Warning Label" to the surface of the STP pump so that the operator can see it clearly at any time (see Figure 7.1, "Attaching Positions of the Cooling Unit and Baking Heater").



- ◇ Check the rated voltage of the baking heater before use.
- ◇ Wind the baking heater around the surface of the STP pump tightly. If the baking heater is not wound tightly, the loose parts will overheat.
- ◇ Procure protective parts for the baking heater, such as a residual current operated circuit breaker and fuses when using the baking heater (remote terminal block TB2 incorporates fuses).
- ◇ DO NOT apply excessive force to the cable for the baking heater.

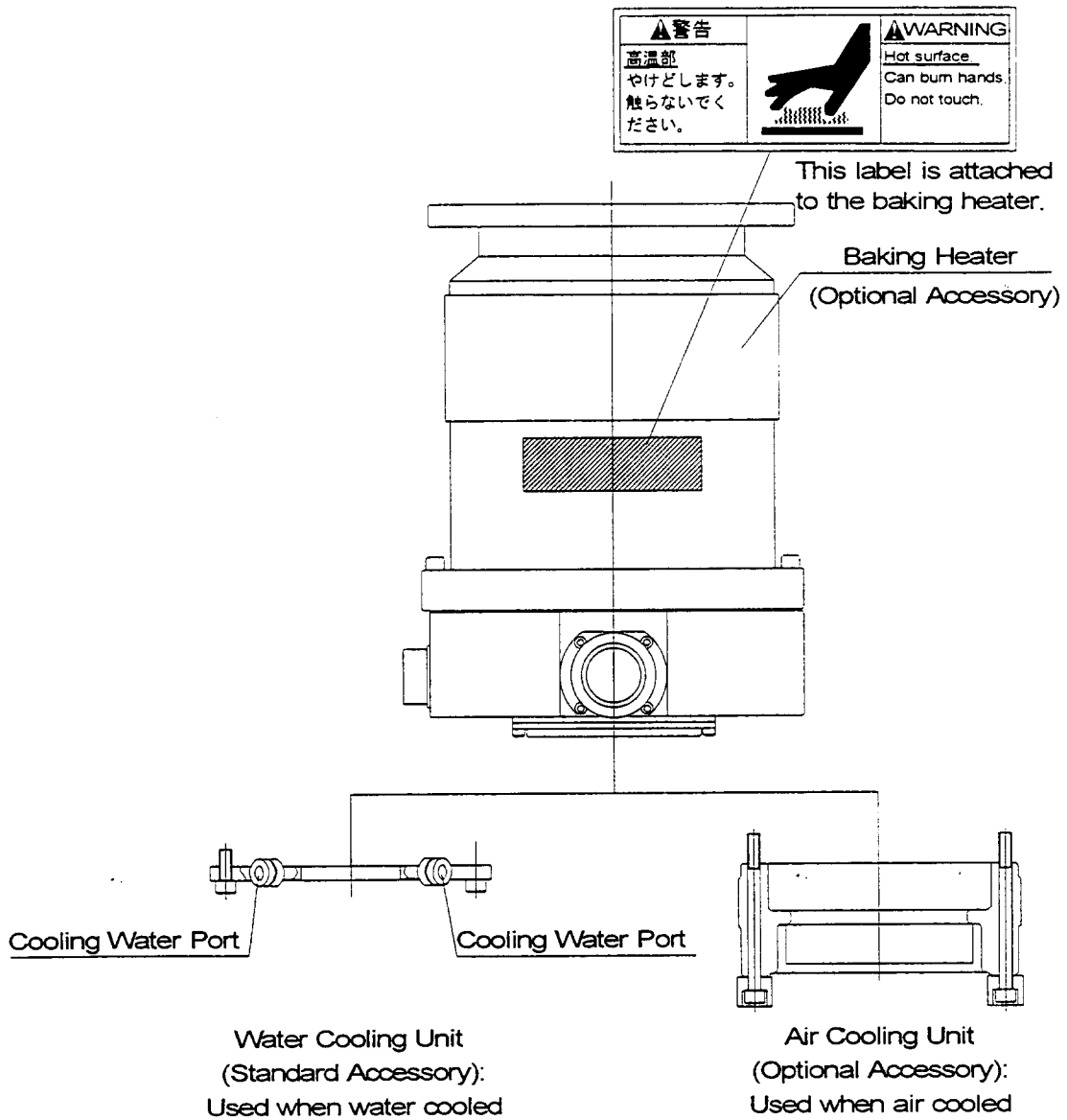

Figure 7.1 Attaching Positions of the Cooling Unit and Baking Heater