

*Operating Instructions*

***TSH 071 / TSU 071***  
***TSH 261 / TSU 261***  
***TSH 521 / TSU 521***

---

***Turbomolecular Drag Pumping Stations***



# Index

	Page	Page
<b>1. Safety Instructions</b> .....	<b>3</b>	
1.1. For Your Orientation.....	3	
1.2. Pictogram Definitions.....	3	
<b>2. Understanding The Pumping Stations</b> .....	<b>4</b>	
2.1. Main Features.....	4	
2.2. Pumping Station Control.....	4	
2.3. Pumping Station Components.....	5	
<b>3. Installation</b> .....	<b>5</b>	
3.1. Preparations For Installation.....	5	
3.2. Laying The Exhaust Line.....	5	
3.3. Venting Units.....	5	
3.4. Electrical Connections.....	6	
3.5. Connecting The Vacuum Unit.....	6	
Connecting The Pumping Station Via A Bellows.....	6	
3.6. Cooling.....	6	
3.7. Pumping Station Connections Plan General Schema.....	7	
Connection Involving Rotary Vane Vacuum Pumps.....	8	
Connection Involving Diaphragm Pumps.....	9	
<b>4. Operations</b> .....	<b>10</b>	
4.1. Transportation Protection.....	10	
4.2. Filling In The Lubricant.....	10	
4.3. Operational Behaviour With Gas Load.....	10	
4.4. Starting.....	11	
4.5. Switching OFF And Venting.....	11	
<b>5. What To Do In Case Of Breakdowns?</b> .....	<b>11</b>	
<b>6. Maintenance</b> .....	<b>12</b>	
6.1. Replacing The Lubricant Reservoir And The Operating Fluid Change.....	12	
<b>7. Service</b> .....	<b>13</b>	
<b>8. Technical Data</b> .....	<b>14</b>	
8.1. Dimensions.....	15	
<b>9. Accessories</b> .....	<b>16</b>	
<b>10. Spare Parts</b> .....	<b>16</b>	
<b>Declaration Of Contamination</b> .....	<b>17</b>	
<b>Declaration OF Conformity</b> .....	<b>(last page)</b>	

**Please note:** Current operating instructions are available via [www.pfeiffer-vacuum.de](http://www.pfeiffer-vacuum.de) under "Infoservice".

# 1. Safety Instructions

- ☞ Read and follow all instructions in this manual.
- ☞ Inform yourself regarding:
  - Hazards which can be caused by the pumping station;
  - Hazards which can be caused by your system;
  - Hazards which can be caused by the medium being pumped.
- ☞ Avoid exposing any part of the body to vacuum.
- ☞ Observe the safety and accident prevention regulations.
- ☞ Regularly check that all accident prevention measures are being complied with.
- ☞ Do not operate the turbo pumping station with open high vacuum flange.
- ☞ Use at least 4 bracket screws to connect the high vacuum flange.
- ☞ The unit has been accredited protection class IP 30. When the unit is operated in environments which require other protection classes, the necessary measures must be taken.
- ☞ Do not carry out any unauthorised conversions or alterations to the turbo pumping station.
- ☞ The control of turbopumping stations has been so designed that the pumps re-start automatically following an interruption to the mains power supply. For this reason, access to the vacuum chambers (for example, via doors, flanges, valves) may only be opened once the pumping station has been switched off.
- ☞ When returning individual components please observe the shipping instructions (refer to the operating instructions for the pumping station components).

Modifications reserved.

## 1.1. For Your Orientation

### Instructions in the text

➔ Working instruction: here, you have to do something.

### Symbols used

The following symbols are used throughout in illustrations.

- ⊕ High vacuum flange
- ❄ Cooling water connection
- ⚡ Electric connection
- ⊙ Exhaust

### Abbreviations used

DCU = Display and operating unit  
TC = Electronic drive unit, turbopump  
TPS = Power unit

### Position numbers

The same pump and accessory parts have the same position numbers in all illustrations.

## 1.2. Pictogram Definitions



Danger of personal injury.



Danger of damage to the pump or the system.



Danger of burns from touching hot parts.



Danger of injury from rotating parts.



Attention to particularly important information on the product, handling the product or to a particular part of the documentation.

## 2. Understanding The Pumping Stations

### 2.1. Main Features

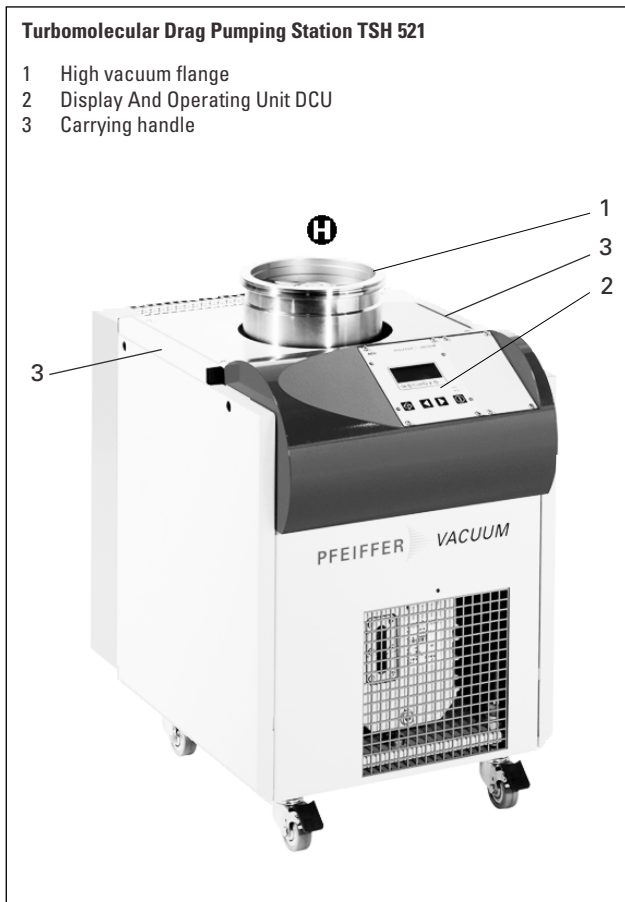

The plug and play type pumping stations are fully automatically operating pumping units.

The integrated power part with the Display And Operating Unit DCU 001 serves to control and monitor the pumping station and works in conjunction with the Electronic Drive Unit TC 600.

#### Cooling

Standard type: Air cooling integrated in the casing (up to 35 °C ambient temperature).

Alternative: Water cooling (please see "Accessories").



Details regarding the pumping station components can be found in the respective operating instructions. The possible pumping station variants and their components are set out in Section 2.3. of these operating instructions.

#### Transport

Lifting gear, which may only be attached to the ring screws, can be used to transport the pumping stations. The threaded holes for the ring screws are located in the high vacuum flange. The two carrying handles 3 (please see the illustration above) are provided only for manual carrying.



Where the delivery of pumping stations include a rotary vane vacuum pump it must be noted that this rotary vane pump is supplied without a filling of operating fluid.

Before first time starting, the rotary vane vacuum pump must be filled with operating fluid. The operating fluid is contained in a pack included with the delivery consignment.



Before first-time starting on pumping stations equipped with a Diaphragm Pump MVP 055-3 or a rotary vane vacuum pump, the transportation protection must be removed (please see the sticker on the pumping station).

For the procedure please refer to Section 4.1..

#### Proper Use

- The turbomolecular pumping stations may only be used for the purpose of generating vacuum.
- The turbomolecular pumping stations may only be operated in the existing configuration.

#### Improper Use

The following is regarded, inter alia, as improper:

- The pumping of explosive or corrosive gases.
- Operating the pumping stations in areas where there is a danger of explosion.
- The use of accessories which are not named in this manual or which have not been agreed by the manufacturer.

Improper use will cause all claims for liability and guarantees to be forfeited.

### 2.2. Pumping Station Control

Pumping Station	Pumping Station Control	Operating Instructions for DCU/TPS
TSH 071 TSU 071	TC 600 with DCU 001 and TPS 100	PM 800 477 BN/ PM 800 521 BN
TSH 261 TSU 261	TC 600 with DCU 001 and TPS 200	
TSH 521 TSU 521	TC 600 with DCU 001 and TPS 300	

## 2.3. Pumping Station Components

Pumping Station Components	TSH 071 TSU 071	TSH 261 TSU 261	TSH 521 TSU 521	Operating Instructions
<b>Turbomolecular Drag Pump</b>	TMH 071 TMU 071	TMH 261 TMU 261	TMH 521 TMU 521	PM 800 504 BN PM 800 470 BN PM 800 496 BN
<b>Diaphragm Pump</b>	MVP 015-2 MVP 035-2 MVP 055-3	MVP 035-2 MVP 055-3	MVP 055-3	PU 0012 BN PU 800 011 BN PU 800 011 BN
<b>Rotary Vane Vacuum Pump</b>	DUO 2.5 UNO 005 A DUO 5 DUO 10	DUO 2.5 UNO 005 A DUO 5 DUO 10	DUO 2.5 UNO 005 A DUO 5 DUO 10	PK 800 152 BN PK 800 152 BN PK 800 197 BN PK 800 170 BN
<b>Venting Valve</b>	TVF 005	TVF 005	TVF 005	PM 800 507 BN

For further accessories please refer to Section 9.

## 3. Installation

### 3.1. Preparations For Installation



Do not carry out any unauthorised conversions or alterations to the turbo pumping station.

- Only remove the blank flange from the high vacuum side immediately before connection.
- The lubricant reservoir is already fitted to turbopumps and filled.
- Where the use of rotary vane vacuum pumps is involved, the operating fluid is included in the delivery consignment and must be filled into the pump before first time operating.
- Diaphragm pumps do not require lubricant.
- Permissible magnetic fields:  
TSH 071/TSU 071 ≤ 4 mT  
TSH 261/TSU 261 ≤ 5.5 mT  
TSH 521/TSU 521 ≤ 5 mT
- The pumping station should be erected on a horizontal surface.

On delivery, the pumping station is provided with four elastic buffers on the underside.

In addition, and to render the pumping station mobile, rollers can be fitted (please see "Accessories").

### 3.2. Laying The Exhaust Line



Please observe the backing pump operating instructions when laying the exhaust line. Exhausted gases and vapours can be hazardous to health and cause environmental pollution.

### 3.3. Venting Units

The pumping stations are equipped with Venting valve TVF 005 as standard.

Control is effected via the pre-selected setting on Electronic Drive Unit TC 600.

The venting mode of the TVF 005 is selected via the DCU.

#### Drying Unit TTV 001 (Accessory)

The drying unit keeps moisture away from the apparatus when venting with atmospheric air.

- ➔ Secure Drying Unit TTV 001 to the rear side of the pumping station casing using the two knurled screws.

Where the casing variant with additional cover for the rotary vane vacuum pump is involved the drying unit must be fitted within this cover.

- ➔ Make the connection to the venting valve with a PVC hose (please refer to "Accessories").

### 3.4. Electrical Connections



The electrical connections must be effected in accordance with local regulations. The voltage requirements shown on the rating plate must comply with the mains voltage.

Alternating current is required for operating the pumping station.

The mains connection cable (length 2.5 m) is provided on the pumping station.

- ➔ Plug in mains connection plug (the pumping station can now be operated).

#### Accessory Connections:

For the electrical connections of accessories please refer to Section 3.7. "Connections Plan".

### 3.5. Connecting The Vacuum Unit



There should be no unilateral loading on the high vacuum flange.

The weight of a vacuum chamber freely flanged on the vacuum flange must not exceed, with the TSH/TSU 071 maximum 200 N (20 kg), with TSH/TSU 261 maximum 500 N (50 kg), and with TSH/TSU 521 maximum 1000 N (100 kg).



The utmost cleanliness must be observed when fitting all high vacuum parts. Unclean components prolong the pumping time.

- ➔ Only remove the blank cover on the high vacuum flange once the vacuum unit is ready for connection so that no moisture, which would prolong the pumping time to attainment of final vacuum, precipitates in the pump.
- ➔ The use of a splinter shield in the high vacuum flange protects against foreign bodies (please see accessories for the turbopump).

### Connecting The Pumping Station Via A Bellows

Advantage: Reduced vibration transmission.

The pumping station must be mechanically anchored.

- ➔ Screw the pumping station to a holder with threaded screws M10. The elastic buffers need not be removed.



Piping must be connected free of stress. A bellows fitted in the piping will compensate for any stress arising.

### 3.6. Cooling

The pumping stations have been designed to be air cooled as standard where ambient temperatures of up to 35 °C are involved.

If required, conversion to water cooling is possible (for water cooling please refer to the "Accessories").



Water cooling is necessary where casing heating is being used.

### 3.7. Pumping Station Connections Plan General Schema

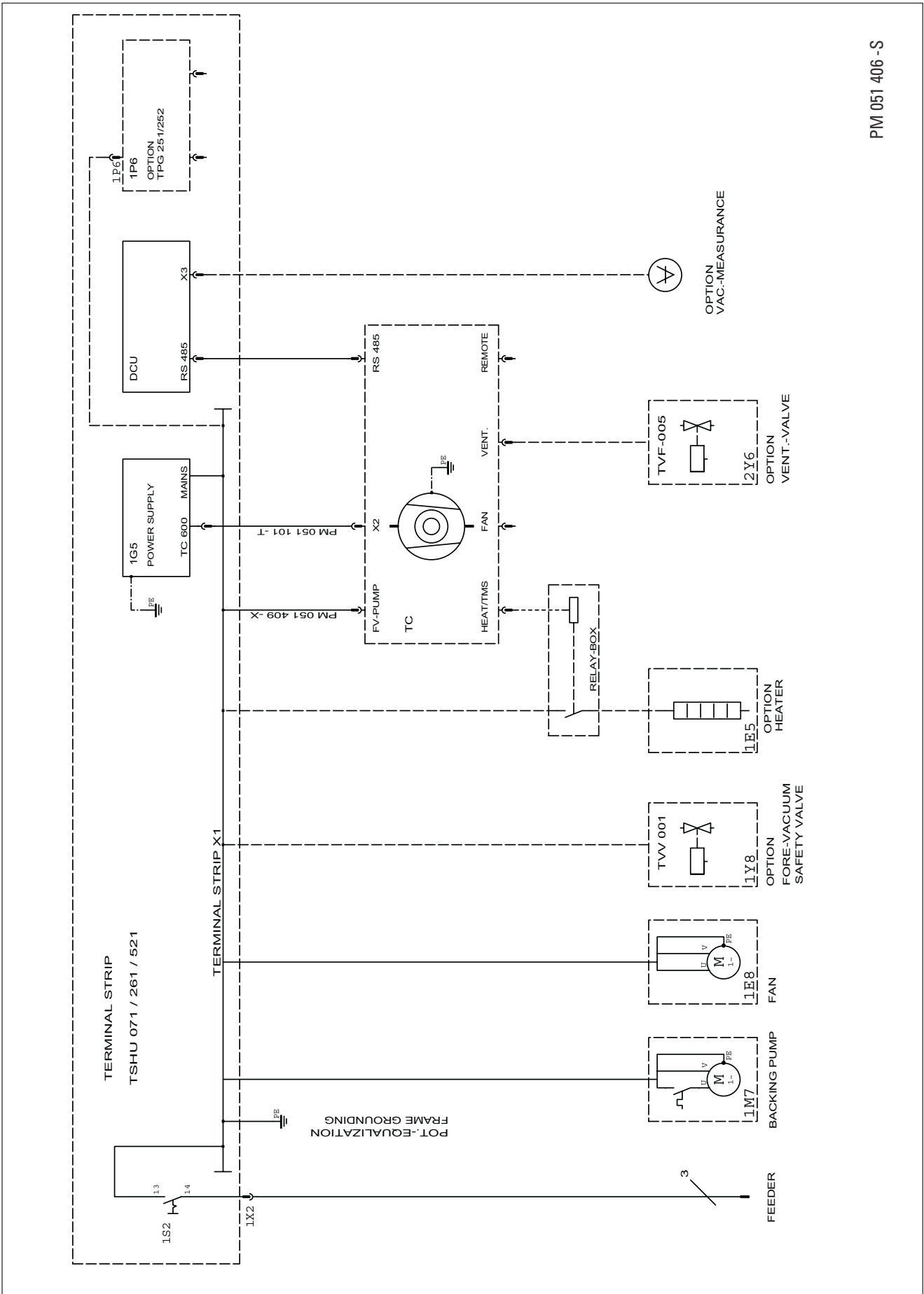

PM 051 406 - S



# Connection Involving Diaphragm Pumps

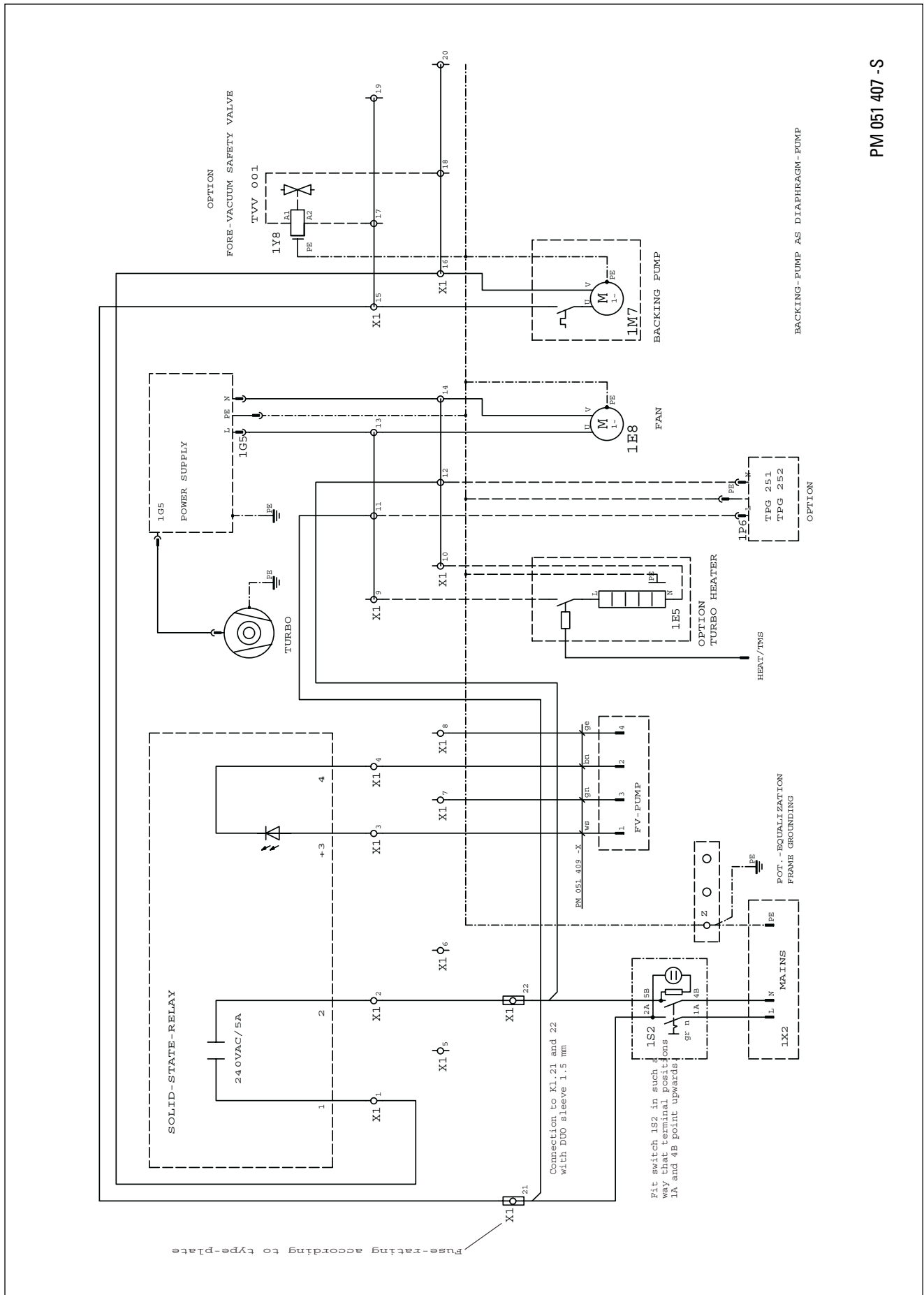

PM 051 407 -S

## 4. Operations

### 4.1. Transportation Protection

Pumping stations which contain a Diaphragm Pump MVP 055-3 or a rotary vane vacuum pump are shipped with transportation protection (please see also the sticker on the pumping station). The following must be removed before first-time starting:

- ➔ Remove both side panels from the pumping station by unscrewing each two screws.
- ➔ Disconnect the earthing cable from the side panels.
- ➔ Unscrew the Allan head screws 10 (M6) from both sides of the pumping station base.

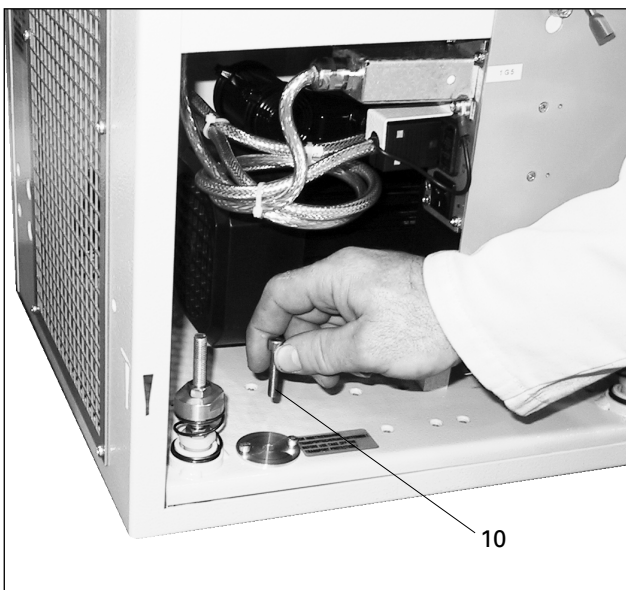
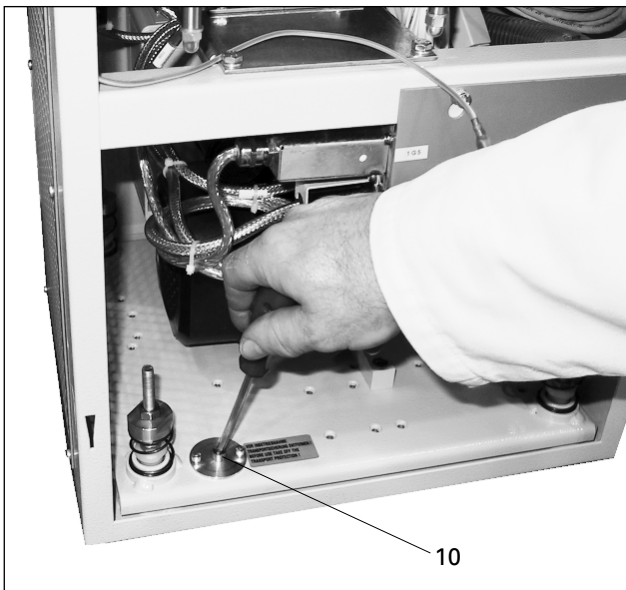

- ➔ The transportation protection is now removed. The side panels can be re-fitted. Caution: Re-connect the earthing cable.

### 4.2. Filling In The Lubricant

- The **turbomolecular drag pump** bearing has been filled with the required amount of lubricant in the works.
- The **diaphragm pump** is lubricated for the whole of its working life.
- The **rotary vane vacuum pump** must be filled with operating fluid P3 before first time starting. A filling of operating fluid is included with the delivery consignment.

#### Procedure:

(please also refer to Section 6.1.).

- ➔ Unscrew two screws on the right-hand side panel. Slightly lift the panel and remove.
- ➔ Unscrew operating fluid filler screw 8.
- ➔ Unscrew the locking screw on the operating fluid flask (included) and screw on the filling hose (in the side panel).
- ➔ Insert the filling hose in the operating fluid filler opening and allow operating fluid to flow in; the amount and type of operating fluid is shown on the rating plate.
- ➔ Screw in operating fluid filler screw 8 and take care with the O-ring.
- ➔ Re-secure the filling hose in the side panel.
- ➔ Fit the side panel back onto the pumping station.

### 4.3. Operational Behaviour With Gas Load



Water cooling is necessary if the pumping station is to be operated with gas load.

Details regarding the operational behaviour with gas load can be found in the respective turbopump operating instructions.

#### 4.4. Starting



Turbopump rotors turn at great speed. When the high vacuum flange is open there is a danger of personal injury and of damage to the pump resulting from the falling in of objects. Therefore, never operate the pump with an open high vacuum flange.

- ➔ With water cooling: Open the cooling water supply and check flow.
- ➔ Switch on the pumping station with the "Pumpstand EIN/AUS" ("pumping station ON/OFF") key (6) on the front panel.

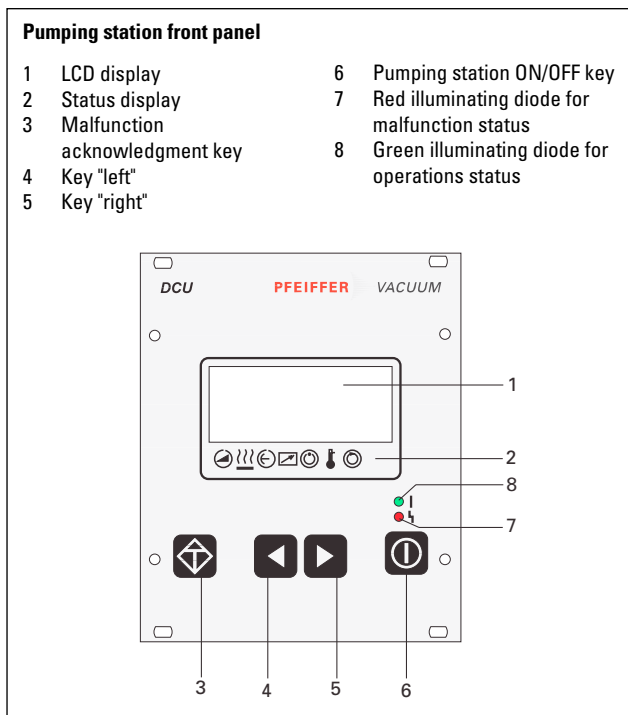

- Once the self test has been successfully completed (duration: TSH/TSU 071 approximately 10 s; TSH/TSU 261 approximately 10 s; TSH/TSU 521 approximately 15 s), the pumping station begins to operate.
- If the vacuum pump does not start after being switched on please refer to "What To Do In Case Of Breakdowns" In the respective operating instructions for the turbopump.
- The turbomolecular drag pump starts up automatically. The start up phase up to attainment of the rotation speed switchpoint is dependent on the size of the vacuum chamber. For start up times in respect of the turbopump please refer to "Technical Data" in the relevant operating instructions.



Where the incidence of water vapour is anticipated, before starting the pumping station it is recommended to open the gas ballast valve on the backing pump by hand. If it is ascertained that the intake pressure of the pump increases or is unusually high, the valve can be opened while the pumping station is running. Once the final pressure has stabilized the valve can be closed again.

#### 4.5. Switching OFF And Venting

- ➔ The complete pumping station is switched off with the key 6 "Pumpstand EIN/AUS" / "pumping station ON/OFF".
- Turbopump and vacuum chamber are vented via Venting Valve TVF 005 which opens for 0.3 seconds when the venting frequency does not attain 50% of the final rotation speed. It then closes again for 10 seconds and is then opened for the venting time of 3,600 seconds (1 hour).
- The venting mode can be changed via the DCU.
- ➔ Where water cooling is involved: Shut off water supply.

## 5. What To Do In Case Of Breakdowns?

Please refer to the operating instructions for the individual components for information on the elimination of malfunctions.

## 6. Maintenance



Maintenance on the individual components of the pumping station should be carried out in accordance with the instructions in the respective sections of the relevant operating instructions.

### 6.1. Replacing The Lubricant Reservoir And The Operating Fluid

- The **diaphragm pump** bearings are lubricated for the whole of their working life.
- The lubricant reservoir in respect of the **turbopump** should be replaced at least once a year. Where extreme operating conditions or unclean processes are involved, the replacement interval should be shorter.

#### Procedure:

- ➔ Unscrew the four screws from the cover plate and remove.
- ➔ Unscrew four screws from the turbopump holding plate.
- ➔ Lift out the turbopump with the holding plate from the pumping station.
- ➔ Carry out the change of the lubricant reservoir in accordance with the turbopump operating instructions.



The Lubricant can contain toxic substances from the medium pumped. Lubricant must be disposed of in accordance with the respective regulations. Safety instructions data sheet for the lubricant on request.

- The operating fluid for the **rotary vane vacuum pump** should be changed at least once a year.

#### Procedure:

- ➔ Unscrew the two screws on the right hand side panel. Slightly lift up the side panel and remove.
- ➔ Unscrew two screws 4 and pull out perforated plate 5 to the right hand side.
- ➔ Exert slight downward pressure on operating fluid duct 6, turn 90° and bring into the forward position.
- ➔ Unscrew operating fluid drain screw 7 and drain operating fluid via operating fluid duct 6 into a suitable container.



The temperature of the operating fluid can be as high as 80 °C.



Toxic gases and vapours can escape from the operating fluid which can be enriched with substances which represent a hazard to health. Disposal must be carried out in accordance with the relevant regulations.

- ➔ Screw back in operating fluid drain screw 7 taking care with the O-ring.
- ➔ Fill in operating fluid as described in Section 4.1. of these operating instructions.
- ➔ Re-fit the perforated plate and the side panel.
- ➔ Check the operating fluid daily where non-stop operations are involved, otherwise each time the pumping station is switched on.



Further information regarding changes of operating fluid can be found in the operating instructions for the respective rotary vane vacuum pump.

#### Changing the operating fluid on rotary vane vacuum pumps

- 4 Screws (2 pieces)
- 5 Perforated plate
- 6 Operating fluid duct
- 7 Operating fluid drain screw
- 8 Operating fluid filler screw
- 9 Sight glass

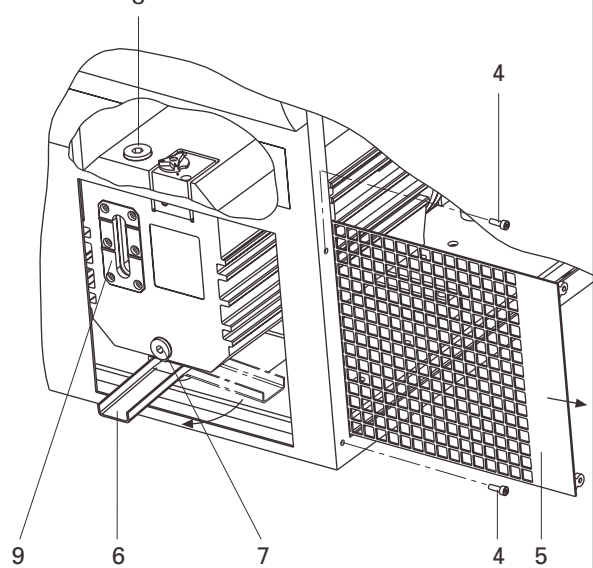

#### Order numbers for the lubricant reservoir on turbopumps and operating fluid on rotary vane vacuum pumps

Lubricant reservoir on turbomolecular pumps		Order number
TMH/U 071		PM 073 073 -T
TMH/U 261		PM 063 265-T
TMH/U 521		PM 063 265 -T
Operating fluid for rotary vane vacuum pumps	Pack size	Order number
P3	1 l	PK 001 106 -T
P3	5 l	PK 001 107 -T
P3	20 l	PK 001 108 -T

## 7. Service

### Do make use of our service facilities

In the event that repairs are necessary on your pumping station a number of options are available to you to ensure any system down time is kept to a minimum:

- Have the pump repaired on the spot by our PFEIFFER Service Engineers,
- Return individual components to the manufacturer for repairs,
- Replace individual components.

Local PFEIFFER representatives can provide full details.

### Before returning:

- ➔ Dismantle all accessories.
- ➔ Drain lubricant/operating fluid (please see Section 6.1.).
- ➔ Please attach a clearly visible notice "Free of harmful substances" (both on the unit and also on the delivery note and any accompanying letters).

"Harmful substances" are substances and preparations as defined in the current, local, dangerous substances regulations; in the U.S.A. as

"materials in accordance with the Code of Federal Regulations (CFR) 49 Part 173.240 Definition and Preparation".

We will carry out the decontamination and invoice this work to you if you have not attached this note. This also applies where the operator does not have the facilities to carry out the decontamination work. Units which are contaminated microbiologically, explosively or radioactively cannot be accepted as a matter of principle.

### Fill out the declaration of contamination

- ➔ In every case the "Declaration of Contamination" must be completed diligently and truthfully.
- ➔ A copy of the completed declaration must accompany the unit; any additional copies must be sent to your local PFEIFFER Service Center.

Please get in touch with your local PFEIFFER representatives if there are any questions regarding contamination.



Decontaminate units before returning or possible disposal. Do not return any units which are microbiologically, explosively or radioactively contaminated.

### Returning contaminated units

If contaminated have to be returned for maintenance/repair, the following instructions concerning shipping must be followed:

- ➔ Neutralise the pump by flushing with nitrogen or dry air.
- ➔ Seal all openings to the air.
- ➔ Seal pump or unit in suitable protective foil.
- ➔ Ship units only in appropriate transport containers.



Repair orders are carried out according to our general conditions of sale and supply.

If repairs are necessary, please send the unit together with a short damage description to your nearest PFEIFFER Service Center.

### Contact addresses and telephone hotline

Contact addresses and telephone numbers can be found on the back cover of these operating instructions.

## 8. Technical Data

Pumping Station	Unit	TSH 071	TSH 071	TSH 071	TSU 071	TSH 261	TSU 261	TSH 521	TSH 521	TSH 521	TSU 521	TSU 521
Connection, nominal diameter		DN 40 ISO-KF	DN 63 ISO-K	DN 63 CF-F	DN 100 ISO-K	DN 100 CF-F	DN 160 ISO-K	DN 100 ISO-K	DN 160 ISO-K	DN 100 CF-F	DN 160 CF-F	DN 160 CF-F
Pumping speed for Nitrogen N <sub>2</sub>	l/s	33	60	60	210	210	300	500	300	500	300	500
Final pressure with rotary vane vacuum pumps	mbar	< 1 · 10 <sup>-10</sup>	< 1 · 10 <sup>-10</sup>	< 1 · 10 <sup>-10</sup>	< 1 · 10 <sup>-9</sup>	< 1 · 10 <sup>-9</sup>	< 1 · 10 <sup>-10</sup>	< 1 · 10 <sup>-10</sup>	< 1 · 10 <sup>-10</sup>	< 1 · 10 <sup>-10</sup>	< 1 · 10 <sup>-10</sup>	< 1 · 10 <sup>-10</sup>
diaphragm pumps	mbar	< 1 · 10 <sup>-9</sup>	< 1 · 10 <sup>-9</sup>	< 1 · 10 <sup>-9</sup>	< 1 · 10 <sup>-8</sup>	< 1 · 10 <sup>-8</sup>	< 1 · 10 <sup>-9</sup>	< 1 · 10 <sup>-9</sup>	< 1 · 10 <sup>-9</sup>	< 1 · 10 <sup>-9</sup>	< 1 · 10 <sup>-10</sup>	< 1 · 10 <sup>-10</sup>
Pumping speed, backing pump at a mains frequency of 50 Hz with Diaphragm Pump	m <sup>3</sup> /h	0,9	0,9	0,9	—	—	—	—	—	—	—	—
MVP 015-2	m <sup>3</sup> /h	2,1	2,1	2,1	2,1	2,1	—	—	—	—	—	—
MVP 035-2	m <sup>3</sup> /h	3,3	3,3	3,3	3,3	3,3	3,3	3,3	3,3	3,3	3,3	3,3
MVP 055-3	m <sup>3</sup> /h	2,5	2,5	2,5	2,5	2,5	2,5	2,5	2,5	2,5	2,5	2,5
Rotary Vane Pump DUO 2.5	m <sup>3</sup> /h	5	5	5	5	5	5	5	5	5	5	5
UNO 5	m <sup>3</sup> /h	5	5	5	5	5	5	5	5	5	5	5
DUO 5	m <sup>3</sup> /h	10	10	10	10	10	10	10	10	10	10	10
Mains connection- power consumption with Diaphragm Pump	VA	140	140	140	—	—	—	—	—	—	—	—
MVP 015-2	VA	280	280	280	380	380	—	—	—	—	—	—
MVP 035-2	VA	300	300	300	400	400	500	500	500	500	500	500
MVP 055-3	VA	230	230	230	330	330	430	430	430	430	430	430
Rotary Vane Pump DUO 2.5	VA	230	230	230	330	330	430	430	430	430	430	430
UNO 5	VA	470	470	470	570	570	670	670	670	670	670	670
DUO 5	VA	650	650	650	750	750	850	850	850	850	850	850
DUO 10	VA	28	28	28	—	—	—	—	—	—	—	—
Weight with Diaphragm Pump	kg	32	32	32	42	42	56	56	56	56	56	56
MVP 015-2	kg	37	37	37	47	47	56	56	56	56	56	56
MVP 035-2	kg	32	32	32	42	42	51	51	51	51	51	51
MVP 055-3	kg	44	44	44	54	54	63	63	63	63	63	63
Rotary Vane Pump DUO 2.5	kg	50	50	50	60	60	69	69	69	69	69	69
UNO 5	kg	32	32	32	42	42	51	51	51	51	51	51
DUO 5	kg	44	44	44	54	54	63	63	63	63	63	63
DUO 10	kg	50	50	50	60	60	69	69	69	69	69	69

## 8.1. Dimensions

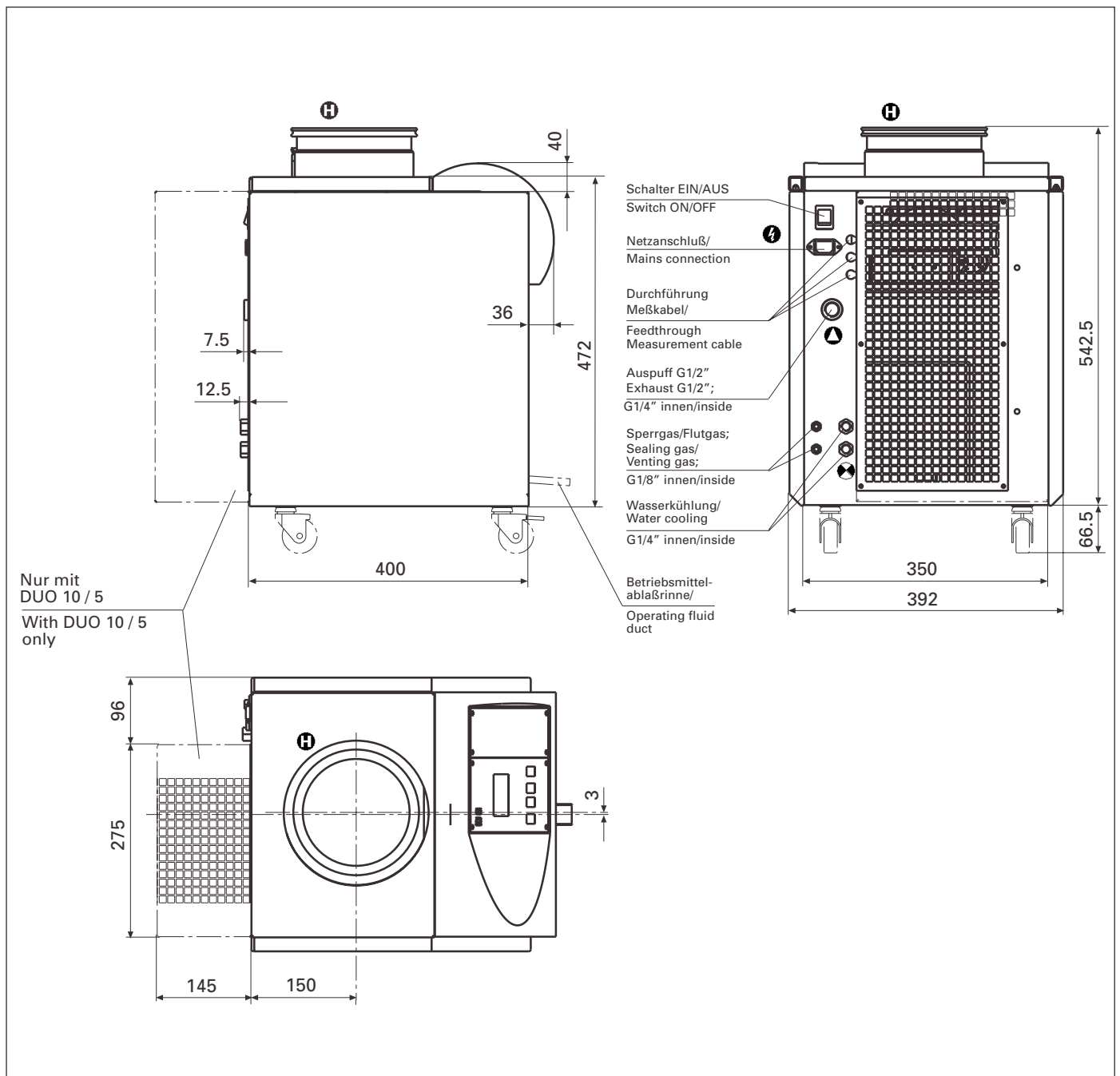

## 9. Accessories

Description	Size	Number	Comments/ relevant operating instructions	Ordering quantity
Drying Unit TTV 001		PM Z00 121	filled with zeolite/ PM 800 022 BN	
Zeolite filling for the drying unit	approx. 260 cm <sup>3</sup>	PM006 786 -T		
Set of rollers consist of: 2 wheels without brakes 2 wheels with brakes 4 screws 4 spring washers	M10 x 16 10,2 x 2,5	P 0994 830 P 3885 259 EA N 3059 469 8P N 3535 913 SP	for mobile pumping station	
Heating sleeve TMH/TMU 071	230 V; Schuko plug 208 V; UL plug 115 V; UL plug	PM 041 900 -T PM 041 901 -T PM 041 902 -T	PM 800 542 BN	
TMH/TMU 261	230 V; Schuko plug 208 V; UL plug 115 V; UL plug	PM 041 903 -T PM 041 904 -T PM 041 905 -T	PM 800 542 BN	
TMH/TMU 521	230 V; Schuko plug 208 V; UL plug 115 V; UL plug	PM 041 996 -T PM 041 097 -T PM 041 098 -T	PM 800 542 BN	
Water cooling TSH/TSU 071 TSH/TSU 261 TSH/TSU 521		PM 016 102 -T PM 016 101 -T PM 016 101 -T		
Oil Mist Filter ONF 25 ONF 4-20 (for DUO 5 and DUO 10)		PM 015 399 -T PM 015 400 -T	PK 800 213 BN PK 800 169 BN	
Oil Mist Filter ONF 16 (for DUO 2.5 and DUO 5)		PM 015 401 -T	PK 800 213 BN	

Further accessories are listed in the operating instructions for the individual components.

When ordering accessories please be sure to state the full part number. Please use this list as an order form (by taking a copy).

## 10. Spare Parts

Spare parts are listed in the relevant operating instructions for the individual components

## Declaration of Contamination of Vacuum Equipment and Components

The repair and/or service of vacuum components will only be carried out if a correctly completed declaration has been submitted. Non-completion will result in delay.

The manufacturer could refuse to accept any equipment without a declaration.

**This declaration can only be completed and signed by authorised and qualified staff:**

**1. Description of component:**

- Equipment type/model: \_\_\_\_\_
- Code No.: \_\_\_\_\_
- Serial No.: \_\_\_\_\_
- Invoice No.: \_\_\_\_\_
- Delivery Date: \_\_\_\_\_

**2. Reason for return:**

\_\_\_\_\_

\_\_\_\_\_

\_\_\_\_\_

\_\_\_\_\_

**3. Equipment condition**

- Has the equipment been used?  
yes  no
- What type of pump oil was used?  
\_\_\_\_\_
- Is the equipment free from potentially harmful substances?  
yes  (go to section 5)  
no  (go to section 4)

**4. Process related contamination of equipment**

- toxic yes  no
- corrosive yes  no
- microbiological hazard\*) yes  no
- explosive\*) yes  no
- radioactive\*) yes  no
- other harmful substances yes  no

\*) We will not accept delivery of any equipment that has been radioactively or microbiologically contaminated without written evidence of decontamination!

Please list all substances, gases and by-products which may have come into contact with the equipment:

Tradename Product name Manufacturer	Chemical name (or Symbol)	Danger class	Precautions associated with substance	Action if spillage or human contact
1.				
2.				
3.				
4.				
5.				

### 5. Legally Binding Declaration

I hereby declare that the information supplied on this form is complete and accurate. The despatch of equipment will be in accordance with the appropriate regulations covering Packaging, Transportation and Labelling of Dangerous Substances.

Name of Organisation: \_\_\_\_\_

Address: \_\_\_\_\_ Post code: \_\_\_\_\_

Tel.: \_\_\_\_\_

Fax: \_\_\_\_\_ Telex: \_\_\_\_\_

Name: \_\_\_\_\_

Job title: \_\_\_\_\_

Date: \_\_\_\_\_ Company stamp: \_\_\_\_\_

Legally binding signature: \_\_\_\_\_



**Konformitätserklärung**  
**Declaration of Conformity**



im Sinne folgender EU-Richtlinien:  
*pursuant to the following EU directives:*

- **Maschinen/Machinery 98/37/EG**
- **Elektromagnetische Verträglichkeit/Electromagnetic Compatibility 89/336/EWG**
- **Niederspannung/Low Voltage 73/23/EWG**

Hiermit erklären wir, daß das unten aufgeführte Produkt den Bestimmungen der EU-Maschinenrichtlinie 98/37/EG - Anhang IIA, der EU-Richtlinie über elektromagnetische Verträglichkeit 89/336/EWG und der EU-Niederspannungsrichtlinie 73/23/EWG entspricht.

*We hereby certify that the product specified below is in accordance with the provision of EU Machinery Directive 98/37/EEC - Annex II A, EU Electromagnetic Compatibility Directive 89/336/EEC and EU Low Voltage Directive 73/23/EEC.*

**Produkt/Product:**

**TSH/TSU 071**  
**TSH/TSU 261**  
**TSH/TSU 521**

Angewendete Richtlinien, harmonisierte Normen und angewendete, nationale Normen:

*Guidelines, harmonised standards, national standards which have been applied:*

<b>EN 292-1</b>	<b>EN 50 081-1</b>
<b>EN 292-2</b>	<b>EN 50 082-2</b>
<b>EN 294</b>	<b>IEC 801 1-4</b>
<b>EN 61 010</b>	<b>VDE 0843-6</b>
<b>EN 55 011</b>	

Unterschrift/Signature:



Pfeiffer-Vacuum GmbH  
Berliner Strasse 43  
35614 Asslar  
Germany

(W. Dondorf)  
Geschäftsführer  
Managing Director

**Zentrale/Headquarters**

Pfeiffer Vacuum GmbH

Berliner Strasse 43  
D-35614 AsslarTelefon 06441/802-0  
Telefax 06441/802-202  
Hotline 06441/802-333  
<http://www.pfeiffer-vacuum.de>**Argentina**ARO S.A., Av. Belgrano 369,  
1092 Buenos Aires, telephone +54 / 11 4331 5766,  
telefax +54 / 11 4331 3572**Australia**Sciteck Australia Pty. Ltd., Suite 1B,  
10-18 Cliff Street, Milsons Point, NSW 2061,  
telephone +61 / 2 9954 1925, telefax +61 / 2 9954 1939**Austria**Pfeiffer Vacuum Austria GmbH  
Diefenbachgasse 35, A-1150 Wien,  
telephone +43 / 1 8941 704, telefax +43 / 1 8941 707  
Service Hotline: +43 / 1 8941704**Branch Office, Czech Republic**Pfeiffer Vacuum Austria GmbH, Branch Prague  
Zvonarska 885  
CZ-156 00 Praha 5  
telephone + 420/2 900 42981, telefax + 420/2 579 23014**Belgium / Luxemburg**Pfeiffer Vacuum Belgium N.V./S.A.  
Luxemburgstraat 5, B-9140 Temse  
telephone +32 / 3 710 5920, telefax +32 / 3 710 5929  
Service Hotline: +32 / 3 710 5922**Brazil**Elmi Tec  
Assistencia Técnica e Representação S/C Ltda.  
Rua Bernadino de Compos, 551-Brooklin  
CEP 04620-002 São Paulo, SP - Brasil  
telephone +55 / 11 5532 0740, telefax +55 / 11 5535 3598**Chile**BERMAT S.A., Coyancura 2283, Oficina 601  
Providencia, P.O. Box 9781, Santiago  
telephone +56 / 2 231 8877, telefax +56 / 2 231 4294**Colombia**Arotec Colombiana S.A., Carrera 16 No. 36-89  
P.O. Box 050 862, Santafe de Bogota / D.C.  
telephone +57 / 1 288 7799, telefax +57 / 1 285 3604**Denmark**Pfeiffer Vacuum Scandinavia AB, Vesterengen 2,  
DK-2630 Taastrup,  
telephone +45 / 43 52 38 00, telefax +45 / 43 52 38 50**France**Pfeiffer Vacuum France SAS  
45, rue Senouque, BP 139  
F-78531 BUC Cedex  
telephone +33 / (0)1 30 83 04 00,  
telefax +33 / (0)1 30 83 04 04**Germany**Pfeiffer Vacuum GmbH,  
Berliner Strasse 43, D-35614 Asslar  
telephone +49 / 6441 802 400, telefax +49 / 6441 802 399  
Service Hotline: +49 / 6441 802 333**Great Britain**Pfeiffer Vacuum Ltd.  
2-4 Cromwell Business Centre  
Howard Way, Interchange Park  
Newport Pagnell, MK16 9QS, United Kingdom  
telephone +44 / 1 908 500615, telefax +44 / 1 908 500616**Greece**Analytical Instruments S.A., 1 Mantzarou St.,  
GR-15451 Athens,  
telephone +30 / 1 674 8973, telefax +30 / 1 674 8978**Hong Kong**Pfeiffer Vacuum Asia Ltd.  
Units 06-07, 17/F, Workingfield Commercial Building,  
408-412 Jaffe Road, Hong Kong  
telephone +852 2575 6688, telefax +852 2575 6993**India**Pfeiffer Vacuum India Ltd.  
25-E Nicholson Road, Tarbunde  
Secunderabad 500 009,  
telephone +91 / 40 775 0014, telefax +91 / 40 775 7774**Israel**ODEM Scientific Applications Ltd.  
9 Hamazmera St., P.O.B. 2001 Nes Ziona  
telephone +972 8 938 0333, telefax +972 8 938 0334**Italy**Pfeiffer Vacuum Italia S.p.a.  
Via San Martino, 44 I-20017 RHO (Milano)  
telephone +39 / 2 93 99 051, telefax +39 / 2 93 99 05 33**Japan**Hakuto Co. Ltd., C.P.O. Box 25,  
Vacuum Scientific Instruments Division  
C.P.O. Box 25, Tokyo 100-91  
telephone +81 / 3 32 258 910, telefax +81 / 3 32 259 011**Korea**Pfeiffer Vacuum Korea Ltd.,  
703 Ho, 853-1, Hankuk Mulru, Dongchonri, Suzi-Eup,  
449-843 Yong-in City, Kyungkido  
telephone +82 / 31 266 0741, telefax +82 / 31 266 0747**Netherlands**Pfeiffer Vacuum Nederland BV  
Veldzigt 30a, NL-3454 PW De Meern,  
telephone +31 / 30 6666050, telefax +31 / 30 6662794**Peru**Ing. E. Brammert s.r.l., José Pardo 182,  
Apartado 173, PE-18 Miraflores,  
telephone +51 / 1 445 8178, telefax +51 / 1 445-1931**Poland**Softrade Sp.z.o.o, ul. Grunwaldzka 391,  
PL-60-173 Poznan, telephone +48 / 61 8677 168,  
telefax +48 / 61 8677 111**Portugal**Unilaser Lda, Taguspark  
Núcleo Central, sala nº 268, Estrada Cacém-  
Porto Salvo, P-2780 Oeiras  
telephone +351 / 1 421 7733, telefax +351 / 1 421 7744**Singapore**APP Systems Services Pte. Ltd, 2 Corporation Road  
06-14 Corporation Place, Singapore 618494,  
telephone +65 / 268 2024, telefax +65 / 268 6621**Spain**Tecnovac  
Tecnologia de Vacío S.L., Ronda de Poniente,  
6 Bajo F, Centro Empresarial Euronova,  
E-28760 Tres Cantos (Madrid)  
telephone +34 / 91 804 11 34, telefax +34 / 91 804 30 91**Sweden**Pfeiffer Vacuum Scandinavia AB  
Johanneslundsvägen 3  
S-194 61 Upplands Väsby  
telephone +46 / 590 748 10, telefax +46 / 590 748 88**Switzerland**Pfeiffer Vacuum Schweiz S.A.  
Förribuckstrasse 30, CH-8005 Zürich  
telephone +41 / 1 444 2255, telefax +41 / 1 444 2266**South Africa**Labotec Pty Ltd., P.O. Box 6553,  
Halfway House  
1685 Midrand  
telephone +27 / 11 315 5434, telefax +27 / 11 315 5882**Taiwan**HAKUTO Taiwan Ltd. Hsinchu office No. 103,  
Hsien Chen 11th Street, Chupei,  
HsinChu County, Taiwan, R.O.C.  
(zip/postal code: 302)  
telephone +886 / 3 554 1020, telefax +886 / 3 554 0867**Thailand**Hakuto (Thailand) Ltd.  
18th Floor, Chokchai Int'l Bldg.  
690 Sukhumvit Road  
Klongton, Klongtoey  
Bangkok 10110  
telephone +662 / 259 6244, telefax +662 / 259 6243**U.S.A.**Pfeiffer Vacuum, Inc.  
24 Trafalgar Square  
Nashua, NH 03063-1988  
USA  
telephone +1 / 603 578 6500, telefax +1 / 603 578 6550**Venezuela**Secotec S.A., Apartado 3452, Caracas 1010-A,  
telephone +58 / 212 573 8687, telefax +58 / 212 573 1932**Other countries**AVI - Applied Vacuum Industries GmbH  
Leginglenstrasse 17A; CH-7320 Sargans  
Switzerland  
telephone +41 / 81 710 03 80  
telefax +41 / 81 710 03 81**Scope of represented countries**Armenia, Azerbaijan, Bangladesh, Belarus, Bulgaria,  
Cambodia, Estonia, Georgia, Kazakhstan, Kingdom of  
Nepal, Kirghizia, Latvia, Lithuania, Maldives,  
Philippines, P.R. China, Rumania, Russia, Tajikistan,  
Turkmenistan, Ukraine, Uzbekistan, Vietnam**A.E.M.S.**Advanced Equipment Materials and Systems  
P.O. Box 25  
Föhrenweg 18  
FL-9496 Balzers  
telephone +423 / 380 0550  
telefax +423 / 380 0551**Scope of represented countries**Bahrain, Egypt, Iraq, Iran, Jordan, Kuwait, Lebanon,  
Lybia, Oman, Pakistan, Saudi-Arabia, Sudan, Syria,  
Turkey, United Arab Emirates, Yemen