

***Turbomolecular Pumps
For Corrosive Gas Processes***



TPH 2303 P C

PT 0094 BE/E (0407)

Index

	Page		Page
1. Safety Instructions	3	5. What To Do In Case	
1.1. For Your Orientation.....	3	Of Breakdowns?.....	16
1.2. Pictogram Definitions.....	3	6. Service	17
2. Understanding The Pump		7. Maintenance/Replacement	18
TPH 2303 P C.....	4	7.1. Replacing The Lubricant.....	18
2.1. Main Features.....	4	7.2. Cleaning The Lubricating Pump.....	18
Proper Use	4	7.3. Replacing The Lubricant Pump.....	19
Improper Use	5	8. Technical Data	20
2.3. Scope Of Delivery	5	8.1. Dimensions Diagram	21
3. Installation	6	9. Spare Parts	23
3.1. Preparations For Installation.....	6	10. Accessories	24
3.2. Installing The Pump, Connecting The		10.1. Lubricant.....	24
High Vacuum Side.....	6	Declaration of Contamination.....	25
3.3. Connecting The Fore-Vacuum Side	9	Manufacturer's Declaration	(last page)
3.4. Connecting The Cooling Unit.....	10		
Cooling From The Cooling Water Mains	10		
Cooling With The Recycled Water			
Cooling Unit TZK (Accessory)	10		
Cooling Water Monitoring	10		
3.5. Connecting The Electronic Drive Unit TCP 3000	11		
3.6. Connecting The Sealing Gas Valve.....	11		
3.7. Connection Diagram.....	12		
4. Operations	13		
4.1. Filling In The Lubricant.....	13		
4.2. Before Switching ON.....	13		
4.3. Switching ON	13		
4.4. Gas Type Dependent Operations	14		
4.5. Circulatory Lubrication.....	15		
4.6. Cycle Counter	15		
4.7. Switching OFF.....	15		
4.8. Shutting Down For Longer Periods	15		

Please note: Current operating instructions are available via internet www.pfeiffer-vacuum.net.

1. Safety Instructions

- ☞ Read and follow all instructions in this manual.
- ☞ Inform yourself regarding:
 - Hazards which can be caused by the pump;
 - Hazards which can be caused by your system.
 - Hazards which can be caused by the media being pumped.
- ☞ Avoid exposing any part of the body to vacuum.
- ☞ Observe the safety and accident prevention regulations.
- ☞ Regularly check that all accident prevention measures are being complied with.
- ☞ Do not operate the turbopump with an open high vacuum flange.
- ☞ Do not carry out any unauthorised conversions or alterations to the turbopump.
- ☞ When returning the turbopump observe the shipping instructions.
- ☞ The turbopump must be anchored in accordance with the installation instructions (please see Section 3.).
- ☞ Do not disconnect the pump cable during operations.
- ☞ When the turbopump is open, disconnect the electronic drive unit from the mains
- ☞ After switching off the turbopump, disconnect the electronic drive unit only after the rotor is stopped.
- ☞ When working on the turbopump, the high vacuum flange should only be opened after the rotor is stopped.
- ☞ When using sealing gas, the pressure in the hose connection should be limited to 2 bar via the overpressure valve.
- ☞ During operation temperatures of up to 65 °C can arise in the lower part of the turbopump. Take care to avoid burns!
- ☞ Keep leads and cables well away from hot surfaces (> 70 °C).
- ☞ Operate the turbopump only in conjunction with the relevant connection cable (please see Section 10. Accessories).
- ☞ The unit has been accredited protection class IP 64. When the unit is operated in environments which require other protection classes, the necessary measures must be taken.
- ☞ The mains connection must be subject to a safe connection to the PE (protection class 1).
- ☞ Do not loosen, remove or replace the housing screws, as otherwise the warranty for the safety of the turbopump will be voided.

Modifications reserved

1.1. For Your Orientation

Instruction in the text

➔ Working instruction: Here, you have to do something.

Symbols used

The following symbols are used throughout in illustrations:

- Ⓜ High vacuum flange
- Ⓥ Fore-vacuum flange
- ⓧ Cooling water connection
- Ⓛ Electric connection
- ⓐ Sealing gas connection
- ⓕ Venting connection

Abbreviations used

TCP = Electronic drive unit, turbopump

Position numbers

The same pump and accessory parts have the same position numbers in all illustrations.

1.2. Pictogram Definitions



Warning, danger of an electric shock.



Warning, danger of personal injury.



Caution, danger of damage to the pump or to the system.



Warning, danger of injury from rotating parts.



Please note, attention to particularly important information on the product, handling the product or to a particular part of the documentation.

2. Understanding The Pump TPH 2303 P C

2.1. Main Features



Cooling

Standard: Water cooling
 Integrated protective measures against excess temperatures: Where motor excess temperature is involved a warning is given and the drive switched off (please see Section 3.4.).



Non-stop operations at full power will result in damage to the pump and without the reaction of the self-protection feature.

Bearings

High vacuum side: Wear free permanent magnetic bearing.
 Fore-vacuum side: Oil circulatory lubricated ball bearing with ceramic balls.



The turbopumps must not be transported when filled with lubricant. When being fitted into or dismantled from a system, turbopumps may **only be positioned as shown in Section 3.2.** Other positions can cause the pumps to be contaminated with lubricant.

Abbreviations on the type plate of the pump

TPH 2303

Suffix "P": Purge gas connection for the prevention of the ingress of aggressive gases into the motor and bearing area.

Suffix "C": Surface protection for passive protection of the pump

Proper Use

- The Turbomolecular Pump TPH 2303 P C may only be used for the purpose of generating vacuum.
- The turbomolecular pump is designed to pump corrosive gases and vapours. Where corrosive gas processes are involved, gas bonding and particles which can damage the surfaces of the pump can be produced. The motor and bearing compartments have to be protected with sealing gas.
- The turbopump may only be used to pump those media against which they are chemically resistant. For other media the operator is required to qualify the pump for the processes involved.
- If the process produces dust, the maintenance intervals must be specified accordingly and sealing gas must be used.
- If the turbopump is to be operated with more than 50% of the permissible gas load then sealing gas must be used to ensure rotor cooling.
- The turbopump must be connected to a backing pump in accordance with Section 3.3.
- The turbopump may only be operated with the Pfeiffer Vacuum Electronic Drive Unit TCP 3000 and relevant cables.
- The turbopump may only be operated providing the ambient conditions in compliance with Protection Type IP 64 are observed.

Improper Use

The following is regarded, inter alia, as improper:

- The pumping of explosive gases.
- Operating the pump in areas where there is a danger of explosion.
- Operating the pump in areas there is a danger of radioactivity.
- The pumping of gases and vapours which attack the materials of the pumps.
- The pumping of corrosive gases without sealing gas.
- The pumping of condensating vapours.
- Operations involving impermissibly high levels of gas loads.
- Operations with improper gas modes.
- Operations with impermissibly high fore-vacuum pressure.
- Operations involving too high levels of heat radiation power (see Section 8. "Technical Data").
- Operating the pump in environments which require a protection class superior to IP 64.
- Installation of the pumps in systems where the turbomolecular pumps are subjected to impact-like stress and vibrations or the effect of periodically occurring forces.
- The use of other power supplies or accessories which are not named in this manual or which have not been agreed by the manufacturer.
- The connection to power supplies with earthing of a direct voltage pole.

The turbomolecular pumps and flange connections must not be used to tread on when climbing onto the system.

Improper use will cause all claims for liability and guarantees to be forfeited.

2.2. Scope Of Delivery

The turbopump scope of delivery includes:

- Lubricant F3 (40 ml) with filling syringe,
- protective covering for the high vacuum flange and the fore-vacuum flange.

3. Installation

3.1. Preparations For Installation



Do not carry out any unauthorised conversions or alterations to the turbopump.



In case the rotor blocks suddenly, torque levels up to **16,000 Nm** can occur which need to be absorbed by the system and the high vacuum flange.



The turbopumps must not be transported when filled with lubricant.

- Pumps must be filled with lubricant before being operated (see Section 4.1.).
- The maximum permissible rotor temperature of the pump is 120 °C. If the vacuum chamber or parts in the vacuum chamber are heated, the values stated in the technical data relating to the level of heat which may be radiated into the pump must not be exceeded. If necessary, suitable shielding must be fitted in the vacuum chamber before the turbopump (constructional suggestions available on request).
- The temperature of the high vacuum flange must not exceed 120 °C.
- Only remove the blank flange from the high and fore-vacuum side immediately before connection.
- Where magnetic fields of > 7 mT are involved suitable shielding must be provided (available on request).
- If the pump is baked out, the heating sleeve and the body of the pump must be insulated to prevent burns from accidental contact.
- Floor mounting of the turbomolecular pump is only admissible after consulting the manufacturer.



The person responsible for commissioning must ensure that the installation is carried out in accordance with the legal regulations and the pertinent industrial standards.

3.2. Installing The Pump, Connecting The High Vacuum Side



The utmost cleanliness must be observed when fitting all high vacuum parts. Unclean components prolong the pumping time. All flange components must be dry and free of grease and dust



To reliably prevent the pump from twisting if the rotor suddenly blocks, it is absolutely prohibited to secure a pump with an ISO-K flange on a vacuum chamber with an ISO-F flange or vice versa. Both flanges **must** be of the same type.

Installation with different flange types is carried out at the user's own risk. Pfeiffer Vacuum shall assume no liability whatsoever for any damage or injuries resulting from this kind of attachment.

Use a Pfeiffer Vacuum splinter shield or protective mesh

The use of a Pfeiffer Vacuum splinter shield or protective mesh in the high vacuum flange protects the turbopump against foreign bodies coming from the vacuum chamber but does reduce the volume flow rate as followed:

		Reduced volume flow rate [%]		
		N ₂	He	H ₂
Splinter shield	DN 200	26	13	10
	DN 250	23	10	7
Protective mesh	DN 200	8	3	3
	DN 250	6	3	2

Connecting via a Pfeiffer Vacuum vibration compensator

The high vacuum side can be flanged onto the vacuum chamber either directly or via a Pfeiffer Vacuum vibration compensator (see Section 10. Accessories).

When using a Pfeiffer vacuum vibration compensator, suitable securing needs to be introduced capable of absorbing the energy of the rotor should it suddenly block, since the vibration compensator itself alone cannot absorb the occurring forces. Please consult the manufacturer.



The maximum permissible temperature at the vibration compensator is 100 °C.

Installing the high vacuum flange

- In case the rotor blocks suddenly, torque levels up to **16,000 Nm** can occur which need to be absorbed by the system and the high vacuum flange.
- For installing the turbomolecular pumps to the high vacuum flange, the components listed in the following **must** be used exclusively. Otherwise the turbomolecular pump may twist or tear off. The components for installing the turbomolecular pumps are special designs from Pfeiffer Vacuum
- The minimum strength of 170 N/mm² of the flange material needs to be observed.

Installation is done as follows:

ISO-K flange

For installing an ISO-K to an ISO-K flange, the following components are available.

Connection nominal diameter	Designation	Order number
DN 200 ISO-K	Centering ring (coated)	PM 016 220 AU
	Centering ring (coated) with splinter shield	PM 016 221 AU
	Centering ring (coated) with protective mesh	PM 016 222 AU
	Bracket screws (24 pieces must be used)	PF 300 110 -T
DN 250 ISO-K	Centering ring (coated)	PM 016 225 AU
	Centering ring (coated) with splinter shield	PM 016 226 AU
	Centering ring (coated) with protective mesh	PM 016 227 AU
	Bracket screws (22 pieces must be used)	PF 300 110 -T

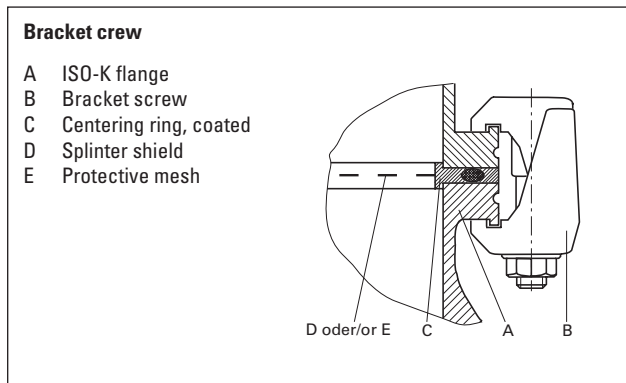

- ➔ The clamps need to be tightened crosswise in three steps. Tightening torque: 5 Nm, 15 Nm, 25 ±2 Nm.

ISO-F flange

For installing an ISO-F to an ISO-F flange there exist three variants.

Variant 1 - Hexagon screw with blind hole

Connection nominal diameter	Designation	Order number
DN 200 ISO-F	Centering ring (coated) and	PM 016 220 AU
	Centering ring (coated) with splinter shield	PM 016 221 AU
	Centering ring (coated) with protective mesh	PM 016 222 AU
	Hexagon screws (12 pieces must be used)	N 3024 479 1C
DN 250 ISO-F	Centering ring (coated) and	PM 016 225 AU
	Centering ring (coated) with splinter shield	PM 016 226 AU
	Centering ring (coated) with protective mesh	PM 016 227 AU
	Hexagon screws (12 pieces must be used)	N 3024 479 1C

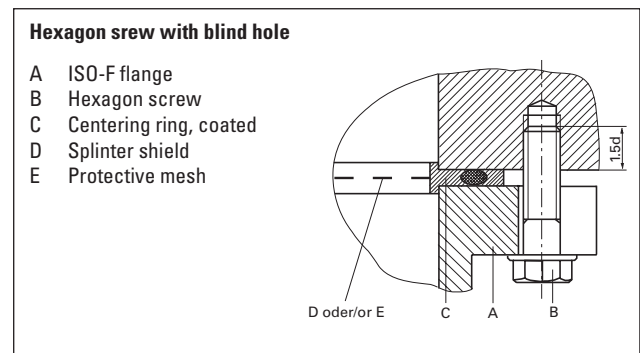

- ➔ For a flange material having a strength of > 270 N/mm² and with a blind hole the hexagon screw 1.5 d must be screwed in. The hexagon screws must be tightened crosswise in three steps. Tightening torque: 10 Nm, 20 Nm, 38 ±3 Nm.

Variant 2 - Stud screw with blind hole

Connection nominal diameter	Designation	Order-number
DN 200 ISO-F	Centering ring (coated)	PM 016 220 AU
	Centering ring (coated) with splinter shield	PM 016 221 AU
	Centering ring (coated) with protective mesh,	PM 016 222 AU
	Stud screws (12 pieces must be used)	N 3169 485 2C
	Nuts (12 pieces must be used)	N 3433 051 8P
DN 250 ISO-F	Centering ring (coated)	PM 016 225 AU
	Centering ring (coated) with splinter shield	PM 016 226 AU
	Centering ring (coated) with protective mesh,	PM 016 227 AU
	Stud screws (12 pieces must be used)	N 3169 485 2C
	Nuts (12 pieces must be used)	N 3433 051 8P

Stud screw with blind hole

- A ISO-F flange
- B Stud screw with nut
- C Centering ring, coated
- D Splinter shield
- E Protective mesh

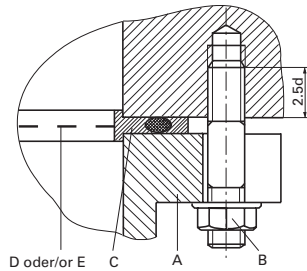

- ➔ For a flange material having a strength of 170-270 N/mm² and a screw-in flange, the stud screw 2.5 d must be screwed in. The nuts must be tightened crosswise in three steps.
Tightening torque: 10 Nm, 20 Nm, 38 ±3 Nm.

Variant 3 - Stud screw and clearance hole

(components as for variant 2; 24 pieces of nuts must be used)

Stud screw and clearance hole

- A ISO-F flange
- B Stud screw with two nuts
- C Centering ring, coated
- D Splinter shield
- E Protective mesh

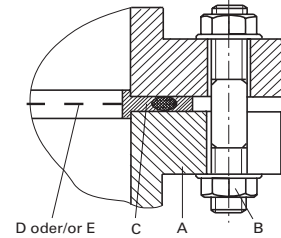

- ➔ For a flange material having a strength of > 170 N/mm² and a stud screw with clearance hole, the nuts must be tightened crosswise in three steps.
Tightening torque: 10 Nm, 20 Nm, 38 ±3 Nm.

Directly Flanging The Pump

The turbopump can be flanged onto the vacuum chamber vertically (0°) up to an angle of 90° maximum.



The fore-vacuum flange must always point downwards.

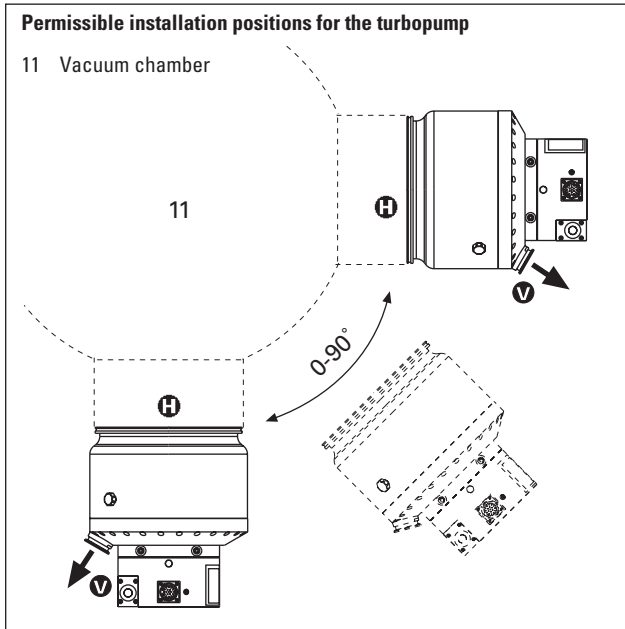

The maximum loading capacity of the high vacuum flange is 2000 N (equivalent to 200 kg). Asymmetric loading on the high vacuum flange must be avoided.

If the pump is being installed horizontally:
The fore-vacuum flange of the turbopump must be aligned downwards (maximum deviation $\pm 15^\circ$), otherwise the turbopump could become dirty and the lubricating pump not properly function.

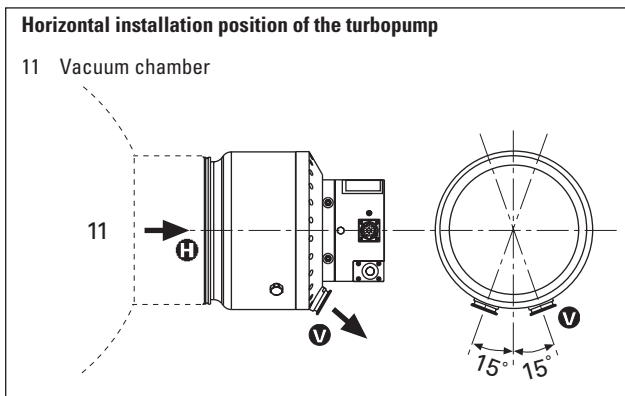

No forces from the piping system must be allowed to act on the pump where turbopumps are anchored. Suspend or support all pipes to the pump.

3.3. Connecting The Fore-Vacuum Side

- Backing pump: Fore-vacuum pressure please see Section 8. Technical Data
- Recommendation: Dry backing pumps or rotary vane vacuum pumps from the Pfeiffer Vacuum range.

Connecting the backing pump

All connections of the fore-vacuum line: With the usual small flange components or screwed hoses.



Be sure to conduct away the exhaust gases from the backing pump. Do not reduce the free cross section of the fore-vacuum flange with following components!



The exhausted process gases and vapours can represent a health hazard and can also be environmentally damaging. Comply with all the gas manufacturer's safety instructions!

- ➔ Fit the vacuum safety valve into the fore-vacuum line (integrated as standard on Pfeiffer Vacuum rotary vane pumps). This prevents vacuum chamber ventilation via the backing pump.
- ➔ On rigid pipe connections: fit a bellows in the connecting line for anti-vibration purposes.

Connecting the backing pump

- 1 High vacuum Connection
- 2 Fore-vacuum connection
- 20 Backing pump
- 21 Intake connection, backing pump
- 22 Vacuum safety valve
- 23 Fore-vacuum line

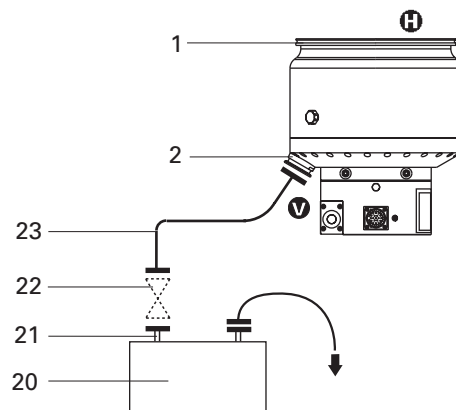

- ➔ The electrical connection for the backing pump: please refer to the operating instructions for the Electronic Drive Unit TCP 3000, PT 0087 BN.

3.4. Connecting The Cooling Unit

Turbopumps type TPH 2303 P C are to be operated with water cooling.

(For cooling water connections please refer to Section 8.1. Dimensions Diagram).

The cooling power must be at least 1000 W.

The cooling water can be drawn either

- from the cooling water mains, or
- from Recycled Water Cooling Unit TZK in closed circuit.

Cooling From The Cooling Water Mains



To prevent deposits collecting in the pump the cooling water must be filtered.

Minimum cooling water requirements:

Mechanically clean, optically clear, no turbidity, no sediment, chemically neutral, temperature >dew point.

Oxygen content:	max. 4 mg/kg
Chloride content:	max. 100 mg/kg
Carbonate hardness:	max. 10 ° dH
Consumption of potassium permanganate:	max. 10 mg/kg
Carbon dioxide:	Undetectable
Ammonia:	Undetectable
pH-value:	7 – 9
Max. fore-line over pressure:	max. 6 bar
Minimum flow rate at gas load max.:	180 l/h at 15 °C

Connection to the cooling water mains

- ➔ Fit dirt trap 33 (see Section 10. Accessories) into the supply line.
- ➔ Connect the supply line using a hose clamp onto one of the two cooling water connections 3.
- ➔ Connect the return line to the other cooling water connection 3 on the turbopump.
- ➔ Screw tight the cooling water connections with a torque of 10 Nm.
- ➔ Tighten all hose clamps and check hoses for firm seating.

Cooling from the cooling water mains

- 3 Cooling water connection
- 31 Supply line
- 32 Return line
- 33 Dirt trap
- 34 Cooling Water Monitor

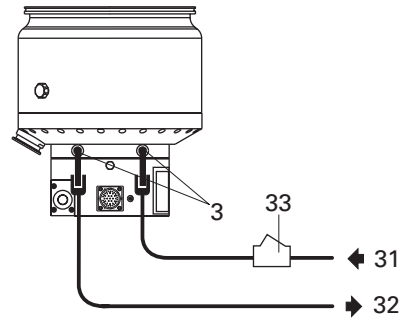

Cooling With The Recycled Water Cooling Unit TZK (Accessory)

Connection to the TZK

Dirt traps are not permissible in the lines.

All other steps as for connecting to the cooling water mains.

Cooling with Recycled Water Cooling Unit TZK

- 3 Cooling water connection
- 31 Supply line
- 32 Return line
- 34 Cooling Water Monitor
- 35 Recycled Water Cooling Unit TZK

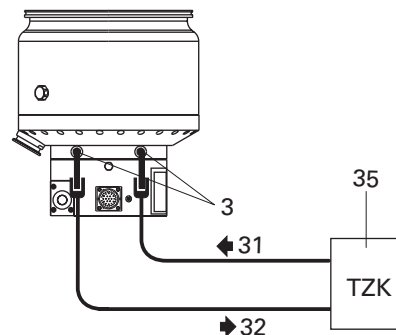

Cooling water monitoring

The cooling water temperature is monitored with a sensor in the pump.

When a limit temperature is reached at the sensor, the warning 58 is triggered on the TCP 3000.

If the temperature drops within 10 minutes below the limit temperature the warning goes out independently.

If the temperature does not drop below the limit temperature again within 10 minutes, the pump is switched off with the error 58.

The error must be cleared manually.

3.5. Connecting The Electronic Drive Unit TCP 3000

(please refer to Section 3.7. Connection Diagram)



Electrical connections must be carried out in accordance with local regulations. Voltage and frequency values on the type plate must concur with mains voltage and mains frequency values.

- ➔ Plug connecting cable 52 (please see Section 10. Accessories) with X2 into the Electronic Drive Unit TCP 3000 and with X7 into the turbopump. After plugging in, interlock bayonet lock (X2/X7).
- ➔ The connection X8 must not be connected on this pump model.



After having been supplied with operating voltage, the Electronic Drive Unit TCP 3000 carries out a self-test to check the supply voltage (duration approximately 8 seconds).



Voltages of 130 V_{eff} can occur on a running down pump on the open electric connection. There is a danger of an electric shock from touching the contacts. Only unplug the connector to the electronic drive unit when the turbopump is completely at rest and the electronic drive unit has been disconnected from the mains.

For further details please refer to Operating Instructions PT 0087 BN for the Electronic Drive Unit TCP 3000.

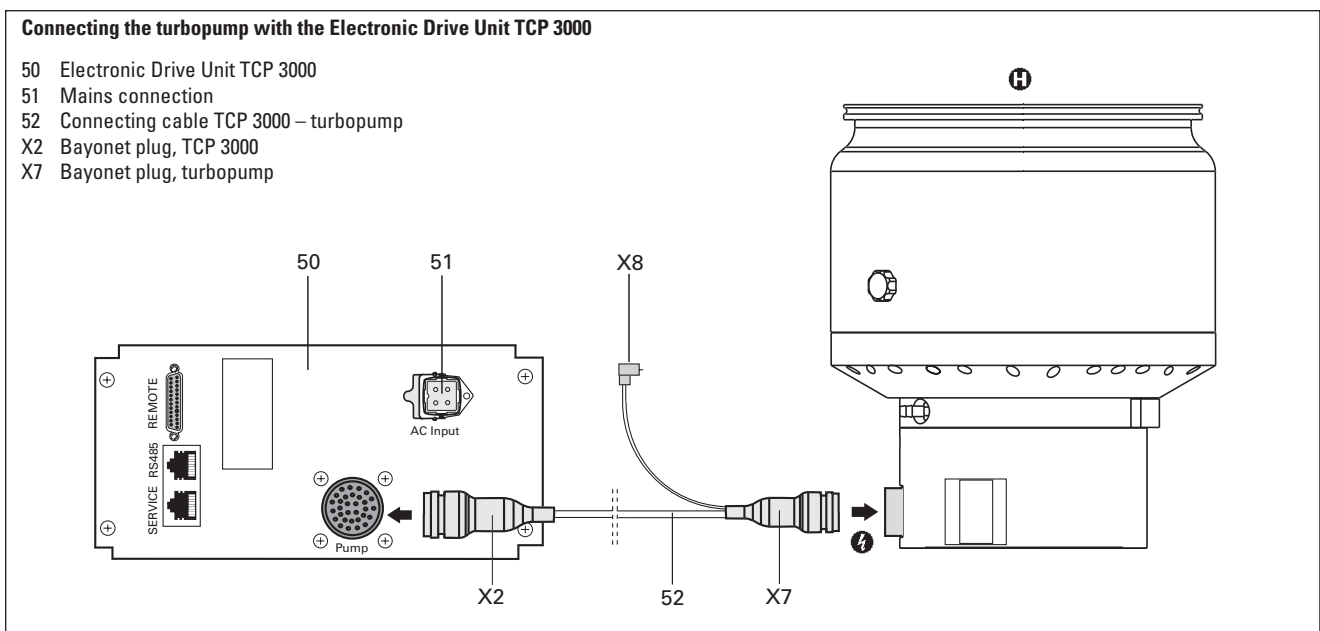

3.6. Connecting The Sealing Gas Valve

It is necessary to operate the turbopump using sealing gas which affords protection for the turbopump, particularly where corrosive and dusty processes are involved.

Even in non-corrosive processes, from 50% of the maximum gas load sealing gas should be used to ensure rotor cooling.

Connection is via a sealing gas valve (please see Section 10. accessories).

Please refer to Operating Instructions PM 800 229 BN for details on installing the sealing gas valve and adjusting the sealing gas flow.

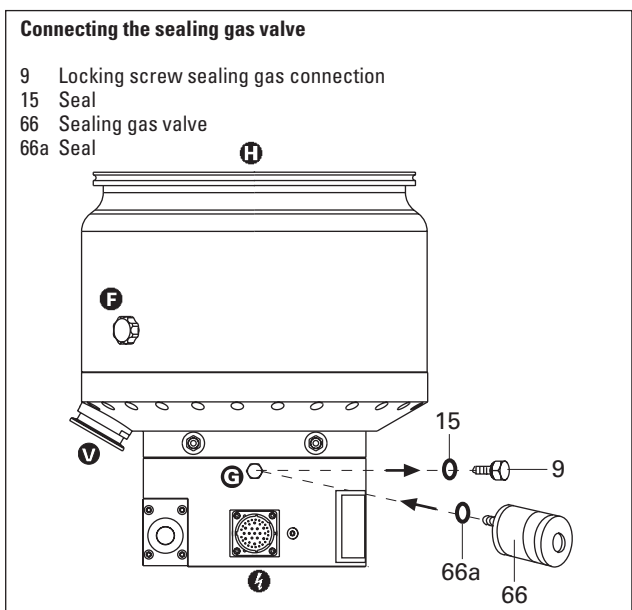

3.7. Connection Diagram

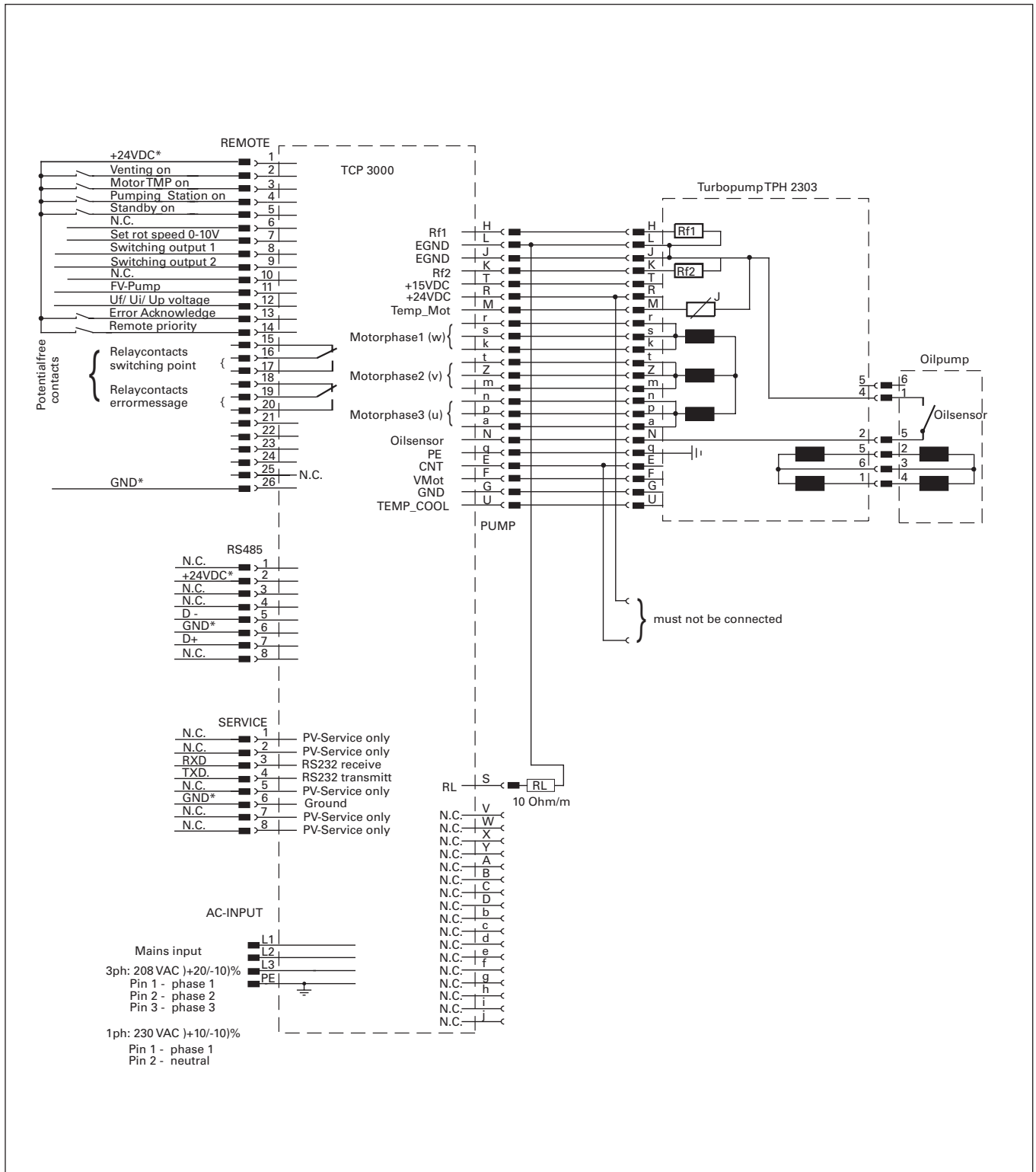

4. Operations

4.1. Filling In The Lubricant



Pumps must be filled with lubricant before being operated.
If possible fill in the lubricant in the fitting position of the pump.

Pumps are designed to operate with Lubricant "F3", contained with the delivery 40 ml (see type plate).



If "F3" is heated above 300 °C, toxic vapours which can harm the airways are given off. Do not allow "F3" to come into contact with tobacco products (danger of poisoning when ignited). The precautions necessary in the handling of chemicals must be observed.

Filling in the lubricant

- ➔ Unscrew lubricant filler screw 71 and, using the syringe A provided, inject approximately 40 ml of lubricant.



Where the set-up position is vertical or horizontal the maximum lubricant level in the sight glass is the lower edge of lubricant filler screw 71.

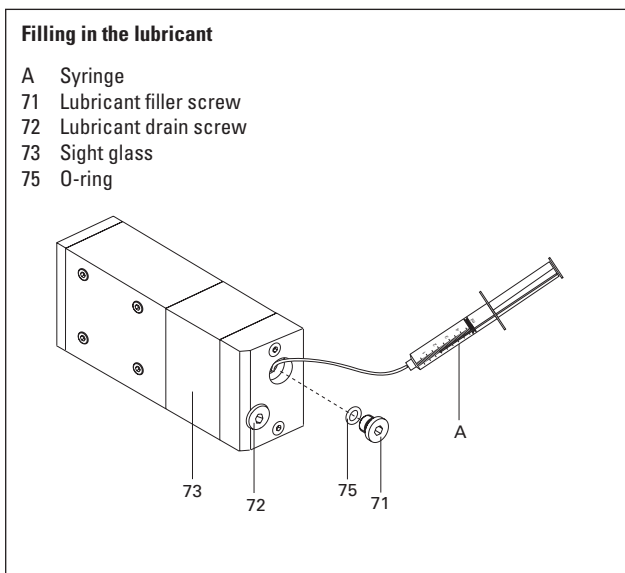

- ➔ Screw back in lubricant filler screw 71 with the O-ring 75.



It is essential to ensure that the lubricating pump is not over-filled with lubricant. Overfilling will cause the excess lubricant to be secreted from the hole for the lubricant filler screw 71.

4.2. Before Switching ON



Turbopump rotors rotate at high speed. When the high vacuum flange is open there is a danger of injury and of damage to the pump caused by objects falling into the pump. Therefore never operate the pump with open high vacuum flange!



Take care when pumping hazardous gases and observe the safety precautions of the gas manufacturer!

- ➔ With the sealing gas valve: open the sealing gas supply.
- ➔ Open the cooling water inlet and check the flow.
- ➔ Make the electrical connection between the turbopump and the Electronic Drive Unit TCP 3000 (please see Section 3.5.).

4.3. Switching ON

Details regarding the switching on of the turbopump are contained in Operating Instructions PT 0087 BN for the Electronic Drive Unit TCP 3000.



When switching on for the first time or after a change of lubricant, the contacts on the lubricating pump can open as a result of degassification. In such cases, as for other malfunctions, the electronic drive unit switches off the turbopump.

- ➔ In remote mode and if a malfunction has occurred, a malfunction acknowledgment is carried out automatically after pump OFF/ON (pin 2 on the remote plug).
- ➔ For operations via the front panel of the TCP 3000, the malfunction or warning signal is reset via the malfunction acknowledgment key.



Malfunction acknowledgment following a lubricant malfunction can occur up to five times. If this malfunction occurs again, the TCP 3000 should be disconnected from the mains for a short time.

4.4. Gas Type Dependent Operations

Where high level gas loads and rotation speeds are involved, the resulting friction subjects the rotor to the effect of great heat. To avoid over-heating, a power rotation speed characteristic line is implemented in the electronic drive unit; this ensures that where maximum gas loads are involved, the pump will operate at any rotation speed without the danger of damage arising.

The maximum power is dependent on the type of gas. Two characteristic lines are available for any type of gas in order to fully exploit the power potential of the pump:

- Gas mode "0" for gases with molecular mass ≥ 40 as, for example, Argon;
- Gas mode "1" for all lighter gases.

Works setting: Gas mode "0"

- ➔ Set the applicable gas mode on the electronic drive unit (please refer to the respective Operating Instructions PT 0087 BN).



Pumping gases with molecular mass ≥ 40 with the incorrect gas mode can cause damage to the pump. When pumping noble gases heavier than Argon it can come to the destruction of the pump. Please contact the manufacturer before using such gases.

For the vertex of the power characteristic line please refer to Section 8. Technical Data.

Maximum power is applied when the pump starts in order to limit the time required. Once the set rotation speed is attained, switching to the selected power characteristic line is automatic.

If the gas dependent mean maximum permissible power is exceeded, the rotation speed is reduced until equilibrium between the permissible power and gas friction is attained. The power limitation serves to protect the pump against thermal over-loading. In order to avoid rotation speed fluctuations it is recommended to set, in rotation speed setting mode, the equilibrium frequency or a somewhat lower frequency.



There can be types of pump whereby there is no differentiation between the two gas modes settings.

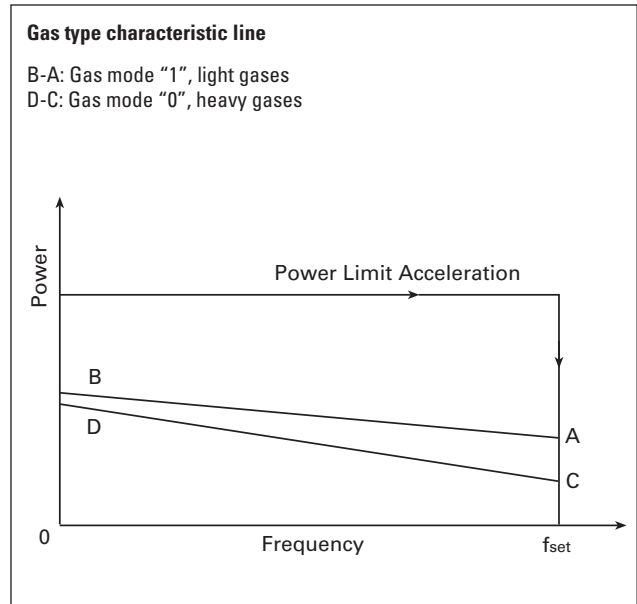

4.5. Circulatory Lubrication

The ball bearing on the fore-vacuum side is supplied with lubricant via the lubricant pump.

The circulation of the lubricant is monitored via a switching contact. If there is insufficient lubricant, the electronic drive unit switches off the turbopump. Monitoring is active only from 45% of the final rotation speed.

If, at a rotation speed of > 45% of the final rotation speed (for example through the degassification of the lubricant), the contact opens for ≥ 2 minutes, the electronic drive unit assumes a lubricant deficiency and switches off the turbopump.



In rotation speed setting mode with set speed below 45% of the rated rotation speed the pump is first accelerated to 45% and then adjusted to the selected rotation speed.

- ➔ Check the lubricant level.
- ➔ Acknowledge the malfunction (please see Section 4.3.).

4.5. Cycle Counter

The turbopumps are equipped with a 106 cycle counter.



Function

If the speed of the turbopump is decreased by more than 5 % by issuing a command to the electronic drive unit, then the cycle counter is increased by one when this speed is reached.



The rotor of the turbo pump is designed for **15,000** cycles. When the **15,000** cycles are reached, the rotor must be replaced.

If the turbopump is operated beyond the 15,000 cycles, there is a danger of complete destruction. Pfeiffer Vacuum shall assume no liability whatsoever for any damage or injuries resulting from such extended operation.

To replace the rotor, please contact your nearest Pfeiffer Vacuum Service Center.

4.7. Switching OFF

Details regarding the switching off of the turbopump are contained in Operating Instructions PT 0087 BN for the Electronic Drive Unit TCP 3000.

- ➔ In remote mode the pump is switched off after pump OFF (pin 2 on the remote plug).
- ➔ For operations via the front panel of the TCP 3000 the pump is switched off via the key ON/OFF.
- ➔ Close the fore-vacuum safety valve (if fitted).
- ➔ Do not switch off Electronic Drive Unit TCP 3000 nor disconnect from the mains until attainment of 0Hz rotation speed.



Where pumping operations involve aggressive gases and their reaction products it is necessary, after switching off the turbopump, to continue backing pump operation and sealing gas function for at least 15 minutes in order to ensure that the aggressive media are completely pumped off to protect the bearing and drive.

4.8. Shutting Down For Longer Periods



Vacuum pumps are sometimes used to pump aggressive or hazardous gases. There is a danger of personal injury resulting from coming into contact with process gases. Before removing a turbopump from the system, first:

- Vent the turbopump with a neutral gas or dry air.
- Ensure that there is no residual process gas in the system nor in the feeder lines.

If the turbopump is to be shut down for more than a year:

- ➔ Remove turbopump from the system.
- ➔ Change the lubricant (see Section 7.1.).
- ➔ Close the high vacuum flange and evacuate the turbopump via the fore-vacuum flange.
- ➔ Vent turbopump via the venting connection with nitrogen or dry air.
- ➔ Close fore-vacuum and venting connection by blank flanging.
- ➔ Place the pump vertically.
- ➔ In rooms with moist or aggressive atmospheres, the turbopump must be air-sealed in a plastic bag together with a bag of desiccant, e.g. silicagel.



If the pump has been shut down for **4 years** a bearing change must be carried out (please get in touch with Pfeiffer Vacuum Service). Usability of the F3 lubricant is 4 years without operation.

5. What To Do In Case Of Breakdowns?

Problem	Possible Causes	Remedy
Pump doesn't start; None of the integrated LEDs glow on the TCP 3000 ¹⁾	<ul style="list-style-type: none"> • Mains supply interrupted • Incorrect operations voltage supplied • No supply of operations voltage • Defect TCP 3000 	<ul style="list-style-type: none"> • Check mains supply • Supply correct operations voltage • Check mains supply • Inform Pfeiffer Vacuum Service of need for repair
Pump doesn't attain nominal rotation speed within the set - start-up time; Pump cuts out during operations	<ul style="list-style-type: none"> • Fore-vacuum pressure too high • Leak or too high levels of gas load • Rotor sluggish caused by defective bearing • Thermal overloading caused by: <ul style="list-style-type: none"> – Insufficient water flow – Fore-vacuum pressure too high – Ambient temperature too high • Lubricant or lubricant pump dirty • Lubricant deficiency 	<ul style="list-style-type: none"> • Check backing pump function • Check seals • Seek leak and repair • Supply of process gas too high; reduce gas load • Check bearing (noises?): Request Pfeiffer Vacuum Service to replace • Ensure free flow • Reduce fore-vacuum pressure • Reduce ambient temperature • Carry out lubricant change as per Section 7.1. or replace the lubricant pump as per Section 7.3. • Check lubricant and replace as necessary
Pump doesn't attain final pressure	<ul style="list-style-type: none"> • Pump dirty • Leak in vacuum chamber, lines or pump 	<ul style="list-style-type: none"> • If contaminated: Request Pfeiffer Vacuum Service to clean • Seek leak starting with vacuum chamber • Repair leak
Unusual operating noises	<ul style="list-style-type: none"> • Bearing damaged • Rotor damaged <ul style="list-style-type: none"> – Foreign particles in the blade area 	<ul style="list-style-type: none"> • Inform Pfeiffer Vacuum Service of need for repair • Inform Pfeiffer Vacuum Service of need for repair
Red LED on the TCP 3000 glows	<ul style="list-style-type: none"> • Collective malfunction 	<ul style="list-style-type: none"> • Differentiated malfunction display via the front display on the TCP 3000, parameter 303 possible. • Where control is via remote ([P:028]=0), confirm via pump ON/OFF. Where control is via the front panel, depress malfunction confirmation key. Where control is via SIO, transmit a malfunction reset command.
Red LED on the TCP 3000 blinks	<ul style="list-style-type: none"> • Warning mains power failure: 	<ul style="list-style-type: none"> • Differentiated warning display via the front display on the TCP 3000, parameter 303 possible. • Check mains supply/mains voltage

1) Please take into account to information in the Operating Instructions for the TCP 3000, PT 0087 BN.

6. Service

Do make use of our service facilities!

In the event that repairs are necessary a number of options are available to you to ensure any system down time is kept to a minimum:

- Have the pump repaired on the spot by our Pfeiffer Vacuum Service Engineers;
- Return the pump to the manufacturer for repairs;
- Replace the pump.



Please take into account that where Pfeiffer Vacuum Service replacement service is involved the standard operating parameters are always pre-set.

If your application requires different parameters, please modify accordingly.

Local Pfeiffer Vacuum representatives can provide full details.

Before returning:

- ➔ Dismantle all accessories.
- ➔ If the unit is free of harmful substances, please attach a clearly visible notice "Free of harmful substances" (both on the unit and also on the delivery note and any accompanying letters).

"Harmful substances" are substances and preparations as defined in the current, local, dangerous substances regulations; in the U.S.A. as "materials in accordance with the Code of Federal Regulations (CFR) 49 Part 173.240 Definition and Preparation". We will carry out the decontamination and invoice this work to you if you have not attached this note.

This also applies where the operator does not have the facilities to carry out the decontamination work.

Fill out the declaration of contamination

- ➔ In every case the "Declaration of Contamination" must be completed diligently and truthfully.
- ➔ A copy of the completed declaration must accompany the unit; any additional copies must be sent to your local Pfeiffer Vacuum Service Center.

Please get in touch with your local Pfeiffer Vacuum representatives if there are any questions regarding contamination.



Decontaminate units before returning or possible disposal. Do not return any units which are microbiologically, explosively or radioactively contaminated.

Returning contaminated units

If contaminated have to be returned for maintenance/repair, the following instructions concerning shipping must be followed:

- ➔ Neutralise the pump by flushing with nitrogen or dry air.
- ➔ Seal all openings to the air.
- ➔ Seal pump or unit in suitable protective foil.
- ➔ Ship units only in appropriate transport containers.



Repair orders are carried out according to our general conditions of sale and supply.

If repairs are necessary, please send the pump together with a short damage description to your nearest Pfeiffer Vacuum Service Center.

Contact addresses and telephone hotline

Contact addresses and telephone numbers can be found on the back cover of these operating instructions.

8. Maintenance / Replacement



No liability for personal injury nor material damage will be accepted for damages and operational interruptions which have been caused by improper maintenance; in addition, all guarantees become invalid.

The bearing should be changed every four years (request Pfeiffer Vacuum Service to change). Where extreme operating conditions or unclean processes are involved, the replacement interval should be checked with your Pfeiffer Vacuum Service Center.

You can change the lubricant and the lubricant pump yourself. Please contact your local Pfeiffer Vacuum Service for all other maintenance and service work.

7.1. Replacing The Lubricant

The lubricant should be replaced at least every 4 years. Where extreme operating conditions or unclean processes are involved, the replacement interval should be checked with your Pfeiffer Vacuum Service Center.



Lubricant screw 72 may only be opened if the turbopump has been vented to atmospheric pressure.



Drain of and fill in the lubricant in the fitting position if possible. If it is absolutely necessary to dismantle the pump to change the lubricant, this may only be carried out in the position shown in Section 3.2. otherwise the lubricant could contaminate the pump.



It is possible to detach the lubricant pump in order to carry out a lubricant change (please see Section 7.3.).

- ➔ Switch off the turbopump, vent to atmospheric pressure and allow to cool as necessary.
- ➔ Unscrew lubricant drain screw 72 and drain lubricant into a suitable container.



Lubricants can contain toxic substances from the medium pumped. Lubricant must be disposed of in accordance with the respective regulations. Safety instructions data sheet for the lubricant on request.

- ➔ Screw back in the lubricant drain screw 72 with the O-ring 75.
- ➔ Unscrew lubricant filler screw 71. Using the syringe provided inject approximately 40 ml (included in the delivery) of lubricant as per the type plate.



Where the set-up position is vertical or horizontal the maximum lubricant level in the sight glass is the lower edge of lubricant filler screw 71.

Filling in the lubricant

- A Syringe
- 71 Lubricant filler screw
- 72 Lubricant drain screw
- 73 Sight glass
- 75 O-ring

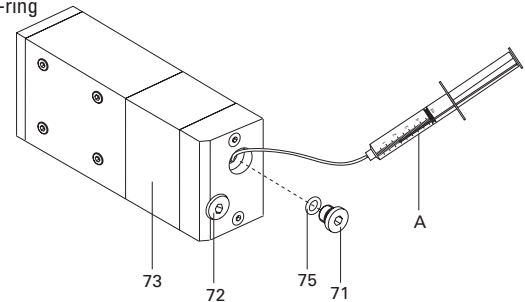

- ➔ Screw in lubricant filler screw 71 with the O-ring 75.



It is essential to ensure that the lubricant pump is not over-filled with lubricant. Overfilling will cause the excess lubricant to be secreted from the hole for the lubricant filler screw 71.

7.2. Cleaning The Lubricant Pump

If, after a malfunction on account of insufficient lubricant, the pump no longer accelerates to the operating rotation speed, the lubricant pump has to be cleaned.

For cleaning the lubricant pump please contact your local Pfeiffer Vacuum Service Center.

7.3. Replacing The Lubricant Pump

If after a malfunction due to an insufficient quantity of lubricant the turbopump cannot be accelerated again up to its operating speed, the lubricant pump needs to be replaced as detailed in the following.

Ordering number for the lubricant pump, see Section 9. Spare Parts.

- ➔ Switch off the turbopump, vent to atmospheric pressure (please see Section 4.6.) and allow to cool as necessary.
- ➔ Unscrew the socket cap screws 83 (4 pieces) from the lubricant pump 77 and remove the lubricant pump from the turbopump.

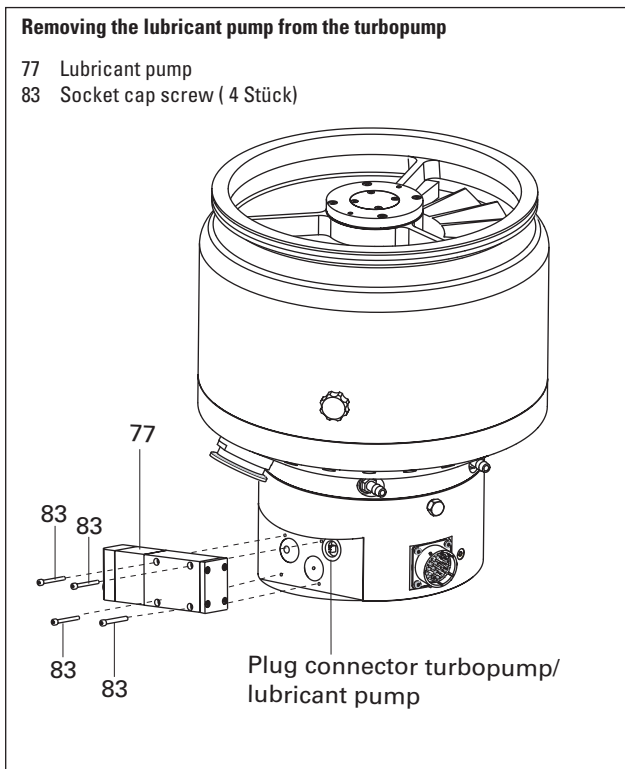

- ➔ Fill in lubricant F3 (approx. 40 ml) into the new lubricant pump as detailed in Section 7.1 (ordering number for “F3” see Section 10.1.).
- ➔ Install the lubricant pump back onto the turbomolecular pump again.

8. Technical Data

Feature	Unit	TPH 2303 P C	
Connection nominal diameter	Inlet Outlet	DN 200 ISO-K DN 40 ISO-KF G 1/8"	DN 250 ISO-K DN 40 ISO-KF G 1/8"
Venting connection			
Electronic drive unit		TCP 3000	
Nominal rotation speed	1/min	33,000	
Start-up time (up to 90% of the nominal rotation speed fore-vacuum pressure $\leq 0,1$ mbar)	min	2	
Noise level	dB (A)	47	
Final pressure, backing pump	mbar	≤ 0.2	
Maximum permissible rotor temperature	$^{\circ}\text{C}$	120	
Permissible heat radiation power	W	80	
Volume flow rate for:			
Nitrogen N_2	l/s	1500	2000
Helium He	l/s	1450	1950
Hydrogen H_2	l/s	1700	1900
Compression ratio for:			
N_2		$>1 \cdot 10^8$	
He		$2 \cdot 10^5$	
H_2		$4 \cdot 10^4$	
Maximum fore-vacuum pressure			
N_2	mbar	2.5	
He	mbar	1.3	
H_2	mbar	0.6	
Mean maximum permissible power at 550 Hz and alternating load	W		
	Gasmode "0"	753	
	Gasmode "1"	842	
Vertex power characteristics lines ¹⁾			
A	W / Hz	842 / 550	
B	W / Hz	1014 / 420	
C	W / Hz	753 / 550	
D	W / Hz	861 / 420	
Final pressure ²⁾			
with rotary vane vacuum pump	mbar	$< 1 \cdot 10^{-8}$	
with UniDry TM 050-4	mbar	$< 1 \cdot 10^{-8}$	
Lubricant			
Type		F3	
Filling volume	ml	40	
Cooling water consumption with water at 15 $^{\circ}\text{C}$ ³⁾	l/h	180	
Cooling water temperature	$^{\circ}\text{C}$	5 - 25	
Weight	kg	47	
Permissible magnetic field	mT	7	
Connection voltage	VAC / Hz 3 phases	85 - 250 / 50/60	
Protection class		IP 64	
Relative humidity of air	%	5 - 85 non condensing	
Cycles		15,000	

1) For gas type characteristics lines please refer to Section 4.4.

2) In accordance with DIN 28 428 the final pressure of a turbomolecular pump is that pressure which is attained in a measuring dome 48 hours after baking out.

3) With maximum gas throughput.

8.1. Dimensions Diagram

TPH 2303 P C,
DN 250 ISO-K/DN 200 ISO-K¹⁾

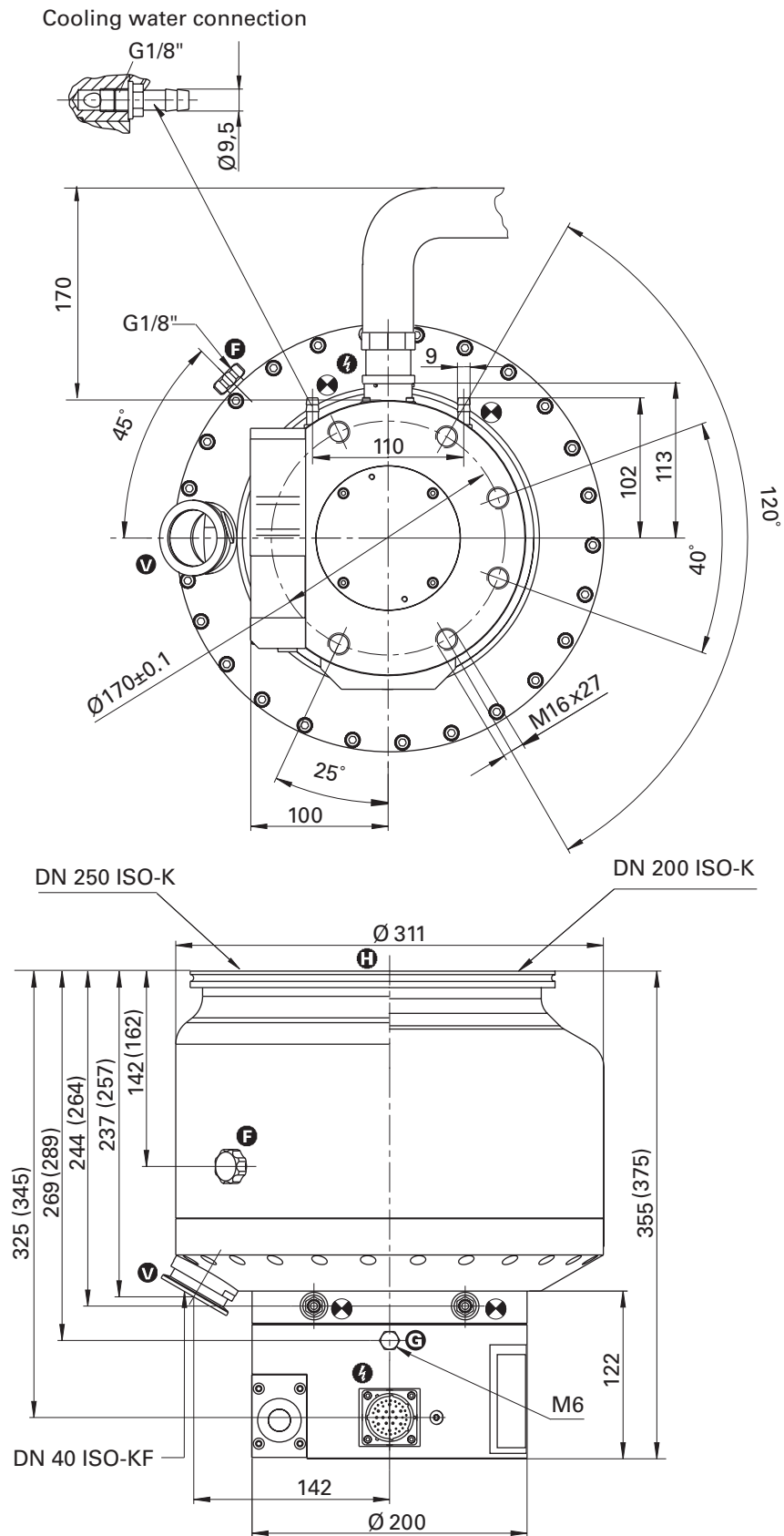

1) Values in parentheses apply to pumps DN 200 ISO-K

9. Spare Parts

Pos.	Description	Pieces	Size	Number	Comments	Ordering Quantity
	Spare parts TPH 2303 P C Set of seals TPH 2303 P C	1		PM 053 460 AT		
17 75	USIT-ring O-ring	3 2	6 x 2,2	P 3529 133 -A P 4070 088 PV		
71 72 77	Lubricant filler screw Lubricant drain screw Lubricant pump (complete)	1 1 1		N 3191 382 X N 3191 382 X PM 083 867 -T		

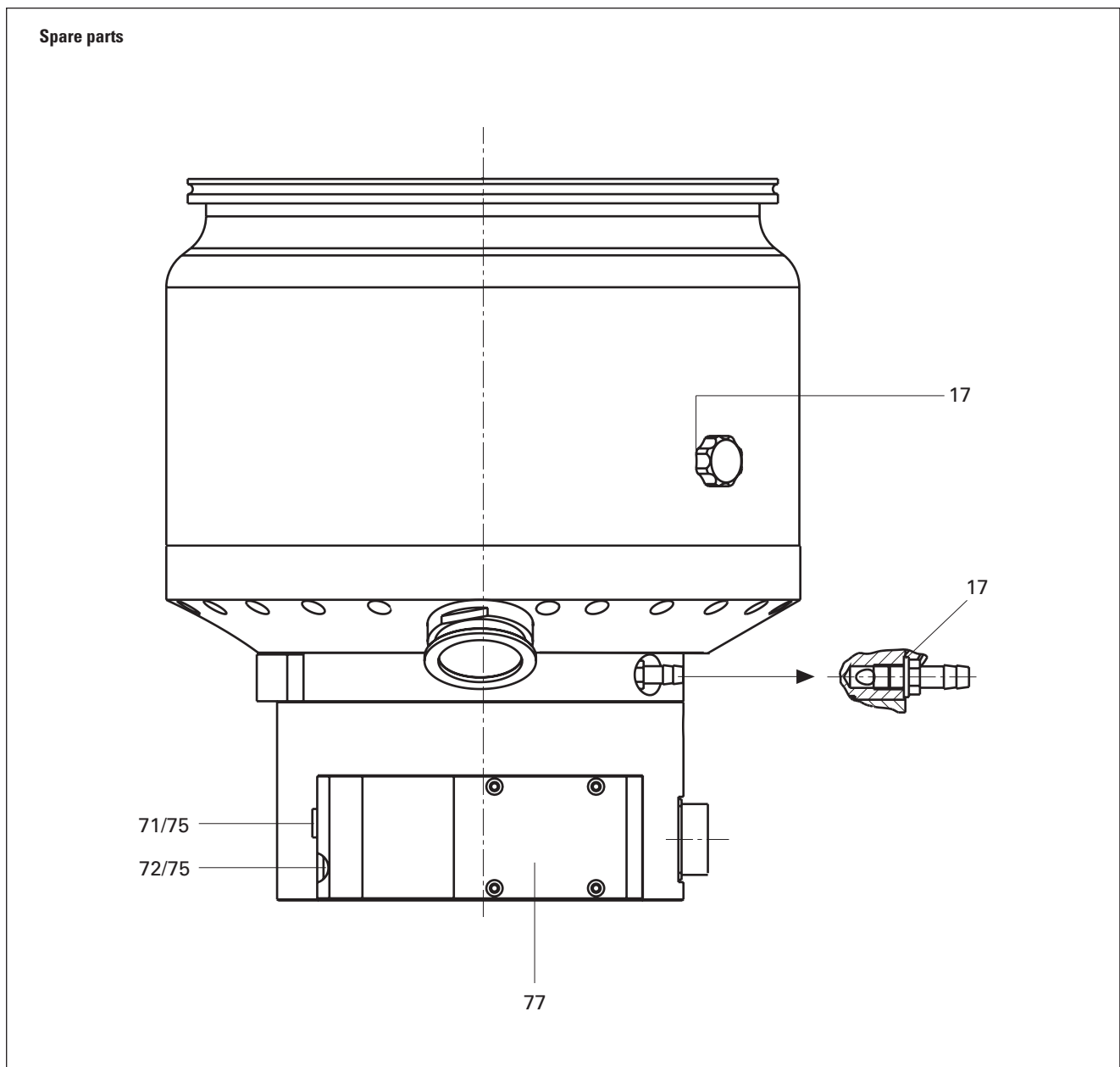

10. Accessories

Description	Size	Number	Comments/ Operating Instructions	Order Quantity
Components for cooling				
Dirt trap Recycled Water Cooling TZK 2000	R 3/8" 230 V, 50 Hz	P 4161 300 2R PM Z01 240	PM 800 369 BN	
Other accessories				
Electronic Drive Unit TCP 3000		PM C01 731		
Connecting cable TCP-turbopump	3 m	PM C51 863 AT	other lengths on request	
Level converter RS 232/485		PM 051 054 -X	PM 800 549 BN	
Hose connection	DN 16 ISO-KF-10	PF 144 020	for the sealing gas valve	
Sealing gas valve	DN 10 ISO-KF	PM Z01 142	PM 800 229 BN	
Fore-Vacuum Safety Valve TVV 001	115 V 230 V	PM Z01 206 PM Z01 205	PM 800 263 BN	
Syringe		PM 006 296 -U		

10.1. Lubricant

Lubricant	Amount	Order Number	Order Quantity
F3	40 ml 250 ml	PM 016 144 -T PM 006 313 -T	

When ordering accessories and spare parts please be sure to state the full part number. When ordering spare parts please state additionally the unit type and unit number (see type plate). Please use this list as an order form (by taking a copy).

Declaration of Contamination of Vacuum Equipment and Components

The repair and/or service of vacuum components will only be carried out if a correctly completed declaration has been submitted. Non-completion will result in delay.

The manufacturer could refuse to accept any equipment without a declaration.

This declaration can only be completed and signed by authorised and qualified staff:

1. Description of component:

- Equipment type/model: _____
- Code No.: _____
- Serial No.: _____
- Invoice No.: _____
- Delivery Date: _____

2. Reason for return:

3. Equipment condition

- Has the equipment been used?
yes no
- What type of pump oil was used?

- Is the equipment free from potentially harmful substances?
yes (go to section 5)
no (go to section 4)

4. Process related contamination of equipment

- toxic yes no
- corrosive yes no
- microbiological hazard*) yes no
- explosive*) yes no
- radioactive*) yes no
- other harmful substances yes no

*) We will not accept delivery of any equipment that has been radioactively or microbiologically contaminated without written evidence of decontamination!

Please list all substances, gases and by-products which may have come into contact with the equipment:

Tradename Product name Manufacturer	Chemical name (or Symbol)	Danger class	Precautions associated with substance	Action if spillage or human contact
1.				
2.				
3.				
4.				
5.				

5. Legally Binding Declaration

I hereby declare that the information supplied on this form is complete and accurate. The despatch of equipment will be in accordance with the appropriate regulations covering Packaging, Transportation and Labelling of Dangerous Substances.

Name of Organisation: _____

Address: _____ Post code: _____

Tel.: _____

Fax: _____ Telex: _____

Name: _____

Job title: _____

Date: _____ Company stamp: _____

Legally binding signature: _____

Herstellererklärung Manufacturer's Declaration

im Sinne folgender EU-Richtlinien:
pursuant to the following EU directives:

- **Maschinen/Machinery 98/37/EWG (Anhang/Annex II B)**
- **Elektromagnetische Verträglichkeit/Electromagnetic Compatibility 89/336/EWG**
- **Niederspannung/Low Voltage 73/23/EWG**

Hiermit erklären wir, dass das unten aufgeführte Produkt zum Einbau in eine Maschine bestimmt ist und dass deren Inbetriebnahme so lange untersagt ist, bis festgestellt wurde, dass das Endprodukt den Bestimmungen der EU-Richtlinie 98/37/EWG entspricht.

Das unten aufgeführte Produkt entspricht den Anforderungen der EU-Richtlinien **Maschinen 98/37/EWG, Elektromagnetische Verträglichkeit 89/336/EWG** und **Niederspannung 73/23/EWG**.

We hereby certify that the product specified below is intended for installation in a machine which is forbidden to be put into operation until such time as it has been determined that the end product is in accordance with the provision of EU Directive 98/37/EEC.

*The product specified below is in correspondence to the EU directives **Machinery 98/37/EEC, Electromagnetic Compatibility 89/336/EEC** and **EU Low Voltage 73/23/EEC**.*

Produkt/Product:

TPH 2303 P C

Angewendete Richtlinien, harmonisierte Normen und angewendete nationale Normen:

Guidelines, harmonised standards, national standards in which have been applied:

EN 292-1 EN 294 EN 1012-2
EN 292-2 EN 61 010

Unterschrift/Signature:



Pfeiffer Vacuum GmbH
Berliner Str. 43
35614 Asslar
Germany

(W. Dondorf)
Geschäftsführer
Managing Director

Herst.I/2003

Adressen • Addresses

Argentina

ARO S.A., Av. Belgrano 369,
1092 Buenos Aires, Phone: +54 / 11 4331 5766,
Fax: +54 / 11 4331 3572, Email: info@aroline.com.ar

Australia

Scitek Australia Pty. Ltd., Suite 1B,
10-18 Cliff Street, Milsons Point, NSW 2061,
Phone: +61 / 2 9954 1925, Fax: +61 / 2 9954 1939,
Email: contact@scitek.com.au

Austria

Pfeiffer Vacuum Austria GmbH
Diefenbachgasse 35, A-1150 Wien,
Phone: +43 / 1 8941 704, Fax: +43 / 1 8941 707
Service Hotline: +43 / 1 8941704,
Email: office@pfeiffer-vacuum.at

Branch Office, Czech Republic

Pfeiffer Vacuum Austria GmbH, Branch Prague
Zvonarska 885, CZ-156 00 Praha 5
Phone: + 420/257 923 888, Fax: + 420/257 923 014
Email: office@pfeiffer-vacuum.cz

Belgium / Luxemburg

Pfeiffer Vacuum Belgium N.V./S.A.
Luxemburgstraat 5, B-9140 Temse
Phone: +32 / 3 710 5920, Fax: +32 / 3 710 5929
Service Hotline: +32 / 3 710 5922,
Email: Sales@pfeiffer-vacuum.be

Brazil

Elmi Tec
Assistencia Técnica e Representação S/C Ltda.
Rua Bernardino de Campos, 551-Brooklin
CEP 04620-002 São Paulo, SP - Brasil
Phone: +55 / 11 5532 0740, Fax: +55 / 11 5535 3598,
Email: elmi-tec@elmi-tec.com.br

Chile

BERMAT S.A., Coyancura 2283, Oficina 601
Providencia, P.O. Box 9781, Santiago
Phone: +56 / 2 231 8877, Fax: +56 / 2 231 4294,
Email: bermat@bermat.cl

Colombia

Arotec Colombiana S.A., Carrera 16 No. 36-95
Apartado 050 862, Santafe de Bogota / Colombia
Phone: +57 / 1 288 7799, Fax: +57 / 1 285 3604,
Email: arotec@arotec.net

Denmark

Pfeiffer Vacuum Scandinavia AB, Vesterengen 2,
DK-2630 Taastrup, Phone: +45 / 43 52 38 00,
Fax: +45 / 43 52 38 50, Email: sales@pfeiffer-vacuum.dk

France

Pfeiffer Vacuum France SAS 45, rue Senouque, BP 139
F-78531 BUC Cedex, Phone: +33 / (0)1 30 83 04 00,
Fax: +33 / (0)1 30 83 04 04, Email: info@pfeiffer-vacuum.fr

Germany

Pfeiffer Vacuum GmbH,
Berliner Strasse 43, D-35614 Asslar
Phone: +49 / 6441 802 400, Fax: +49 / 6441 802 399
Service Hotline: +49 / 6441 802 333,
Email: Info@pfeiffer-vacuum.de

Great Britain

Pfeiffer Vacuum Ltd.
2-4 Cromwell Business Centre
Howard Way, Interchange Park
Newport Pagnell, MK16 9QS, United Kingdom
Phone: +44 / 1 908 500615, Fax: +44 / 1 908 500616,
Email: sales@pfeiffer-vacuum.co.uk

Greece

Analytical Instruments S.A., 1 Mantzarou St.,
GR-15451 Athens, Phone: +30 / 210 674 8973-7,
Fax: +30 / 210 674 8978, Email: contact@analytical.gr

Hong Kong

Pfeiffer Vacuum Asia Ltd.
c/o Hakuto Enterprises Ltd.
8th Floor World Trade Center
No. 280 Gloucester Road
Causeway Bay
Hong Kong
Phone: +852 2578 4921, Fax: +852 2807 2498,
Email: sales@pfeiffer-vacuum.com.hk

India

Pfeiffer Vacuum India Ltd.
25-5 Nicholson Road, Tarbund
Secunderabad 500 009,
Phone: +91 / 40 2775 0014, Fax: +91 / 40 2775 7774,
Email: pfeiffer@vsnl.net

Israel

ODEM Scientific Applications Ltd.
9 Hamazmera St., P.O.B. 2001 Nes Ziona
Phone: +972 8 938 0333, Fax: +972 8 938 0334,
Email: odemltd@isdn.net.il

Italy

Pfeiffer Vacuum Italia S.p.a.
Via San Martino, 44 I-20017 RHO (Milano)
Phone: +39 / 2 93 99 051, Fax: +39 / 2 93 99 05 33,
Email: contact@pfeiffer-vacuum.it

Japan

Hakuto Co. Ltd., C.P.O. Box 25,
Vacuum Scientific Instruments Division
C.P.O. Box 25, Tokyo 100-91, Phone: +81 / 3 32 258 910,
Fax: +81 / 3 32 259 011, Email: pfeiffer@hakuto.co.jp

Korea

Pfeiffer Vacuum Korea Ltd.,
703 Ho, 853-1, Hankuk Mulru, Dongchonri, Suzi-Eup,
449-843 Yong-in City, Kyungkido,
Phone: +82 / 31 266 0741, Fax: +82 / 31 266 0747,
Email: sales@pfeiffer-vacuum.co.kr

Netherlands

Pfeiffer Vacuum Nederland BV
Veldzigt 30a, NL-3454 PW De Meern,
Phone: +31 / 30 6666050, Fax: +31 / 30 6662794,
Email: Sales@pfeiffer-vacuum.nl

Peru

Ing. E. Brammert s.r.l., José Pardo 182,
Apartado 173, PE-18 Miraflores, Phone: +51 / 1 445 8178,
Fax: +51 / 1 445-1931, Email: braming@terra.com.pe

Poland

Softtrade Sp.z.o.o, ul. Grunwaldzka 391,
PL-60-173 Poznan, Phone: +48 / 61 8677 168,
Fax: +48 / 61 8677 111, Email: softtrade@softtrade.com.pl

Portugal

Tecnovac
Tecnologia de Vacio S.L.,
Sector Literatos, 38 - Local 1,
ES-28760 Tres Cantos (Madrid)
Phone: +34 / 91 804 11 34, Fax: +34 / 91 804 30 91,
Email: tecnovac@tecnovac.es

Singapore

APP Systems Services Pte Ltd, 11, Toh Guan Road East,
#03-01 APP Enterprise Building, Singapore 608603,
Phone: +65 / 6425 6611, Fax: +65 / 6560 6616,
Email: sales@appsyste.ms.com.sg

Spain

Tecnovac
Tecnologia de Vacio S.L.,
Sector Literatos, 38 - Local 1,
ES-28760 Tres Cantos (Madrid)
Phone: +34 / 91 804 11 34, Fax: +34 / 91 804 30 91,
Email: tecnovac@tecnovac.es

Sweden

Pfeiffer Vacuum Scandinavia AB
Johanneslundsvägen 3
SE-194 61 Upplands Väsby, Phone: +46 / 8 590 748 10,
Fax: +46 / 8 590 748 88, Email: sales@pfeiffer-vacuum.se

Switzerland

Pfeiffer Vacuum Schweiz S.A.
Förrlibuckstraße 30, CH-8005 Zürich
Phone: +41 / 1 444 2255, Fax: +41 / 1 444 2266
Email: info@pfeiffer-vacuum.ch

South Africa

Labotec Pty Ltd., P.O. Box 6553,
Halfway House, 1685 Midrand
Phone: +27 / 11 315 5434, Fax: +27 / 11 315 5882,
Email: sales@labotec.co.za

Taiwan

HAKUTO Taiwan Ltd. Hsinchu office No. 103,
Hsien Chen 11th Street, Chupei,
HsinChu County, Taiwan, R.O.C. (zip/postal code: 302)
Phone: +886 / 3 554 1020, Fax: +886 / 3 554 0867,
Email: leo-shih@hakuto.com.tw

Thailand

Hakuto (Thailand) Ltd.
18th Floor, Chokchail Intil Bldg.
690 Sukhumvit Road, Klongton, Klongtoey, Bangkok 10110
Phone: +662 / 259 6244, Fax: +662 / 259 6243,
Email: tmgroup@hakutothailand.com

U.S.A.

Pfeiffer Vacuum, Inc.
24 Trafalgar Square
Nashua, NH 03063-1988, USA
Phone: +1/ 603 578 6500, Fax: +1/ 603 578 6550,
Email: contact@pfeiffer-vacuum.com

Venezuela

Secotec S.A., Apartado 3452, Caracas 1010-A,
Phone: +58 / 212 573 8687, Fax: +58 / 212 573 1932,
Email: secotec@cantv.net

Other countries

AVI - Applied Vacuum Industries GmbH
Leginglenstrasse 17A; CH-7320 Sargans

Switzerland

Phone: +41 / 81 710 03 80
Fax: +41 / 81 710 03 81
Email: avi@bluewin.ch

Scope of represented countries

Armenia, Azerbaijan, Bangladesh, Belarus, Bulgaria, Cambodia, Estonia, Georgia, Kazakhstan, Kingdom of Nepal, Kirghizia, Latvia, Lithuania, Maldivia, Philippines, P.R. China, Rumania, Russia, Tajikistan, Turkmenistan, Ukraine, Uzbekistan, Vietnam

A.E.M.S.

Advanced Equipment Materials and Systems
P.O. Box 25
Föhrenweg 18
FL-9496 Balzers
Phone: +423/ 380 0550
Fax: +423/ 380 0551
Email: aems@adon.li

Scope of represented countries

Bahrain, Egypt, Iraq, Iran, Jordan, Kuwait, Lebanon, Lybia, Oman, Pakistan, Saudi-Arabia, Sudan, Syria, Turkey, United Arab Emirates, Yemen

Zentrale/Headquarters

Pfeiffer Vacuum GmbH
Berliner Strasse 43
D-35614 Asslar

Telefon 06441/802-0
Telefax 06441/802-202
Hotline 06441/802-333
www.pfeiffer-vacuum.net

PFEIFFER  **VACUUM**