

# **Turbomolecular Pumps**

## **For Up-side Down Installation**



**TPH 2101 U P**  
**TPH 2101 U P C**

# Index

	Page	Page
<b>1. Safety Instructions.....</b>	<b>3</b>	
1.1. For Your Orientation .....	3	
1.2. Pictogram Definitions .....	3	
<b>2. Understanding The Pumps.....</b>	<b>4</b>	
2.1. Main Features .....	4	
Proper Use.....	4	
Improper Use.....	5	
2.2. Differences Between The Pump Types.....	5	
2.3. Scope Of Delivery .....	5	
<b>3. Installation.....</b>	<b>6</b>	
3.1. Preparations For Installation .....	6	
3.2. Connecting The High Vacuum Side .....	6	
3.3. Connecting The Fore-Vacuum Side .....	8	
3.4. Connecting The Cooling Unit.....	9	
3.5. Connecting The Electronic Drive Unit TC 750	10	
3.6. Installing The Power Supply .....	10	
3.7. Installing The Cover Plate For The TC 750.....	11	
3.8. Connecting The Venting Valve.....	12	
3.9. Connecting The Sealing Gas Valve .....	12	
3.10. Connecting The Remote Control Unit.....	13	
3.11. Connecting The Serial Interface RS 485 .....	14	
Connection.....	14	
Connecting The RS 485 .....	14	
3.12. Connections Diagram .....	15	
<b>4. Operations.....</b>	<b>16</b>	
4.1. Filling In The Lubricant.....	16	
4.2. Before Switching ON.....	16	
4.3. Switching ON.....	17	
4.4. Gas Type Dependent Operations .....	17	
4.5. Circulatory Lubrication .....	18	
4.6. Switching OFF And Venting.....	18	
4.7. Shutting Down For Longer Periods .....	18	
4.8. Operations With The DCU 001/DCU 600 or HPU 001 .....	18	
4.9. Operations With The Remote Control Unit.....	19	
Venting Release (Optional) .....	19	
Motor, Turbopump .....	19	
Pumping Station .....	19	
Heating/Reset .....	19	
Standby.....	19	
Rotation Speed Setting Operations Via Input PWM .....	19	
Switching Outputs .....	19	
<b>5. Monitoring Operations.....</b>	<b>20</b>	
5.1. Operations Display Via LED .....	20	
5.2. Turbopump Temperature Monitoring .....	20	
<b>6. What To Do In Case     Of Breakdowns?.....</b>	<b>21</b>	
<b>7. Service .....</b>	<b>22</b>	
<b>8. Maintenance/Replacing .....</b>	<b>23</b>	
8.1. Replacing The Lubricant .....	23	
8.2. Cleaning The Lubricating Pump .....	24	
8.3. Replacing The Lubricating Pump .....	24	
8.4. Replacing The Electronic Drive Unit TC 750 ...	24	
<b>9. Technical Data .....</b>	<b>25</b>	
9.1. Dimensions Diagram .....	26	
<b>10. Spare Parts .....</b>	<b>27</b>	
<b>11. Accessories .....</b>	<b>28</b>	
11.1. Lubricant .....	28	
<b>Declaration of Contamination .....</b>	<b>29</b>	
<b>Manufacturer's Declaration .. (last page)</b>		

**Please note:** Current operating instructions are available via [www.pfeiffer-vacuum.net](http://www.pfeiffer-vacuum.net)

For information about certifications, if applicable, please see the signet on the pump or:

ESF [www.tuvdotcom.com](http://www.tuvdotcom.com)

ESF TUVdotCOM-ID 0000021320

# 1. Safety Instructions

- ☞ Read and follow all instructions in this manual.
- ☞ Inform yourself regarding:
  - Hazards which can be caused by the pump;
  - Hazards which can be caused by your system.
  - Hazards which can be caused by the media being pumped.
- ☞ Avoid exposing any part of the body to vacuum.
- ☞ Observe the safety and accident prevention regulations.
- ☞ Regularly check that all accident prevention measures are being complied with.
- ☞ Do not operate the turbopump with open high vacuum flange.
- ☞ Do not carry out any unauthorised conversions or alterations to the turbopump with TC 750.
- ☞ When returning the turbopump observe the shipping instructions.
- ☞ The turbopump must be anchored in accordance with the installation instructions (please refer to Section 3.).
- ☞ Do not disconnect the plug between the TC 750 and accessory components during operations.
- ☞ Disconnect the voltage supply to the TC 750 before opening the turbopump.
- ☞ When working on the turbopump, the high vacuum flange should only be opened once the rotor is at rest.
- ☞ When using sealing gas, the pressure in the hose connection should be limited to 2 bar via the overpressure valve.
- ☞ If a heater is in use temperatures of up to 120 °C can arise in the area of the high vacuum flange. Take care to avoid burns!
- ☞ During operations temperatures of up to 65 °C can arise in the lower part of the turbopump. Take care to avoid burns!
- ☞ Keep leads and cables well away from hot surfaces (> 70 °C).
- ☞ Operate the turbopump with TC 750 only in conjunction with the relevant power supply (accessory).
- ☞ The unit has been accredited protection class IP 30. When the unit is operated in environments which require other protection classes, the necessary measures must be taken. When the turbopump is water cooled the enclosed cover plate for the TC 750 must be installed by an electrical specialist, in order to attain protection class IP 54.
- ☞ The mains connection must be subject to a safe connection to the PE (protection class 1).
- ☞ If the turbopump and the TC 750 are operated separately (only permissible with the agreement of the manufacturer) the turbopump must be connected to the PE.
- ☞ The turbopump and the TC 750 must only be disconnected from each other when the turbopump is completely at rest and the TC 750 has been disconnected from the power supply.
- ☞ The cause of any operating voltage leakage to earth (red LED flashes) must be eliminated to avoid the danger of an electric shock.
- ☞ The housing screws do not loosen, pull tight, remove or replace, since otherwise the guarantee for the security of the turbopump expires.

Modifications reserved.

## 1.1. For Your Orientation

### Instruction in the text

➔ Working instruction: here, you have to do something.

### Symbols used

The following symbols are used throughout in illustrations:

- ⓘ High vacuum flange
- Ⓥ Fore-vacuum flange
- ⓕ Venting connection
- ❄ Cooling water connection
- ⚡ Electric connection
- Ⓒ Sealing gas connection

### Abbreviations used

DCU = Display and operating unit  
HPU = Display and operating unit  
TC = Electronic drive unit, turbopump  
TPS = Power supply

### Position numbers

The same pump and accessory parts have the same position numbers in all illustrations.

## 1.2. Pictogram Definitions



Warning, danger of personal injury.



Caution, danger of damage to the pump or to the system.



Warning, danger of injury from rotating parts.



Please note, attention to particularly important information on the product, handling the product or to a particular part of the documentation.

## 2. Understanding The Pumps

### 2.1. Main Features

Turbopumps TPH 2101 U P/TPH 2101 U P C with the TC 750 form a complete unit. Voltage is supplied by power supply (see Section 11. Accessories).



On delivery, the pumps have been set up for operations in remote mode. Remote plug 8d (please refer to Section 3.5.) should therefore be disconnected from the TC 750 if operations with the DCU 001/DCU 600 or HPU 001 are required.

#### Turbomolecular Pump TPH 2101 U P

- 1 High vacuum flange
- 2 Fore-vacuum flange
- 3 Cooling water connection
- 4 Venting screw
- 8 Electronic Drive Unit TC 750
- 71 Lubricant filler screw
- 72 Lubricant drain screw
- 73 Sight glass



#### Cooling

Standard: Water cooling  
 Integrated protective measures against excess temperatures:  
 The Electronic Drive Unit TC 750 reduces the rotor rotation speed.

#### Bearings

High vacuum side: Wear free permanent magnetic bearing.  
 Fore-vacuum side: Oil circulatory lubricated ball bearing with ceramic balls.



The turbopumps must **not** be transported when filled with lubricant.

When being fitted into or dismantled from a system, turbopumps may only be positioned as shown in Section 3.2. Other positions can cause the pumps to be contaminated with lubricant.

#### Ambient conditions

The turbomolecular pump needs to be installed in compliance with the following ambient conditions:

<b>Installation location:</b>	protected against the weather (rooms within buildings)
<b>Temperature:</b>	+5 °C to +40 °C
<b>Relative humidity of the air:</b>	max. 80 % at $T \leq 31$ °C up to max. 50% at $T \leq 40$ °C
<b>Air pressure:</b>	77 kPa - 106 kPa
<b>Installation altitude:</b>	2000 m max.
<b>Pollution degree:</b>	2
<b>Overvoltage category:</b>	II
<b>Connection voltage:</b>	140 VDC $\pm 5\%$

#### Proper Use

- The Turbomolecular Pumps TPH 2101 U P and TPH 2101 U P C may only be used for the purpose of generating vacuum.
- The Turbomolecular Pumps TPH 2101 U P C are designed to pump corrosive gases and vapours. Where corrosive gas processes are involved, gas bonding and particles which can damage the surfaces of the pump can be produced. The motor and bearing compartments have to be protected with sealing gas.
- The turbopumps may only be used to pump those media against which they are chemically resistant. For other media the operator is required to qualify the pumps for the processes involved.
- If the process produces dust, the maintenance intervals must be specified accordingly and sealing gas must be used.
- If the pump is to be operated with more than 50% of the permissible gas load then sealing gas should be used to ensure rotor cooling.
- The turbopump must be connected to a backing pump in accordance with Section 3.3..
- Only Pfeiffer Vacuum power supplies may be used to operate the TC 750. The use of other power supplies requires the prior agreement of the manufacturer and equalisation with the valid specification.
- Without the cover plate for the TC 750 the pumps may only be operated providing the ambient conditions in compliance with Protection Type IP 30 are observed.

## Improper Use

The following is regarded, inter alia, as improper:

- The pumping of explosive gases.
- Operating the pumps in areas where there is a danger of explosion.
- Operating the pumps in areas where there is a danger of radioactivity.
- The pumping of gases and vapours which attack the materials of the pumps.
- The pumping of corrosive gases without sealing gas.
- The pumping of condensating vapours.
- Operations involving impermissibly high levels of gas loads.
- Operations with impermissibly high fore-vacuum pressure.
- Operations with improper gas modes.
- Operations involving too high levels of heat radiation power (see Section 9. Technical Data).
- Venting with rates higher than in Section 4.6. stated.
- Operating the pump in environments without the cover plate for the TC 750 which require a protection class superior to IP 30.
- Installation of the pumps in systems where the turbomolecular pumps are subjected to impact-like stress and vibrations or the effect of periodically occurring forces.
- The use of other power supplies or accessories which are not named in this manual or which have not been agreed by the manufacturer.
- The connection to power supplies with earthing of a direct voltage pole.

The turbomolecular pumps and flange connections must not be used to tread on when climbing onto the system.

Improper use will cause all claims for liability and guarantees to be forfeited.

## 2.2. Differences Between The Pump Types

TPH 2101 U P  
TPH 2101 U P C

Standard version  
Corrosive gas version

Feature	TPH 2101 U P	TPH 2101 U P C
High vacuum flange	ISO-K	ISO-K
High vacuum seal	Elastomer seal	Elastomer seal
Attainable final pressure	$< 1 \cdot 10^{-7}$ mbar	$< 1 \cdot 10^{-7}$ mbar

### Abbreviations on the type plate of the pump

#### TPH 2101

- Suffix "U": Upside down fitting of the turbomolecular pump
- Suffix "P": Purge gas connection for the prevention of the ingress of aggressive gases into the motor and bearing area
- Suffix "C": Surface protection for passive protection of the pump

## 2.3. Scope Of Delivery

The turbopump scope of delivery includes:

- Lubricant F3 (40 ml) with filling syringe,
- cover plate for the TC 750 to fulfilled the conditions for protection class IP 54 (please see Section 3.7.),
- protective covering for the high vacuum flange and the fore-vacuum flange.



The fastening parts at the high vacuum flange are not sufficient for the attachment of the turbopump at a recipient (please refer to Section. 3. Installation).

# 3. Installation

## 3.1. Preparations For Installation



Do not carry out any unauthorised conversions or alterations to the turbopump.



In case the rotor blocks suddenly, torque levels up to **16000 Nm** can occur which need to be absorbed by the system and the high vacuum flange.



The turbopumps must not be transported when filled with lubricant.

- Pumps must be filled with lubricant before being operated (see Section 4.1.).
- If the turbopump is to be operated with the DCU 001 or HPU 001, the remote plug 8d on the TC 750 (please see Section 3.5.) should be disconnected and then proceed in accordance with the corresponding operating instructions.
- The maximum permissible rotor temperature of the pump is 120 °C. If the vacuum chamber or parts in the vacuum chamber are heated, the values stated in the technical data relating to the level of heat which may be radiated into the pump must not be exceeded. If necessary, suitable shielding must be fitted in the vacuum chamber before the turbopump (constructional suggestions available on request).
- The temperature of the high vacuum flange must not exceed 120 °C.
- Only remove the blank flange from the high and fore-vacuum side immediately before connection.
- Where magnetic fields of > 7 mT are involved suitable shielding must be provided (available on request).
- If the pump is baked out, the heating sleeve and the body of the pump must be insulated to prevent burns from accidental contact.
- Floor mounting of the turbomolecular pump is admissible after consulting the manufacturer.



The person responsible for commissioning must ensure that the installation is carried out in accordance with the legal regulations and the pertinent industrial standards.

## 3.2. Connecting The High Vacuum Side



The utmost cleanliness must be observed when fitting all high vacuum parts. Unclean components prolong the pumping time. All installation units for the flange must be with installation grease-free, dust free and drying.



To reliably prevent the pump from twisting if the rotor suddenly blocks, it is absolutely prohibited to secure a pump with an ISO-K flange on a vacuum chamber with an ISO-F flange or vice versa. Both flanges **must be** of the same type.

Installation with different flange types is carried out at the user's own risk. Pfeiffer Vacuum shall assume no liability whatsoever for any damage or injuries resulting from this kind of attachment.

### Use a Pfeiffer Vacuum splinter shield or protective mesh

The use of a Pfeiffer Vacuum splinter shield or protective mesh in the high vacuum flange protects the turbopump against foreign bodies coming from the vacuum chamber but does reduce the volume flow rate as followed:

		Reduced volume flow rate [%]		
		N <sub>2</sub>	He	H <sub>2</sub>
Splinter shield	DN 200	25	13	10
	DN 250	23	10	7
Protective mesh	DN 200	7	4	2
	DN 250	6	3	2

### Connecting via a Pfeiffer Vacuum vibration compensator

The high vacuum side can be flanged onto the vacuum chamber either directly or via a Pfeiffer Vacuum vibration compensator (see Section 11. Accessories).

When using a Pfeiffer vacuum vibration compensator, suitable securing needs to be introduced capable of absorbing the energy of the rotor should it suddenly block, since the vibration compensator itself alone cannot absorb the occurring forces. Please consult the manufacturer.



The maximum permissible temperature at the vibration compensator is 100 °C.

## Installing the high vacuum flange

- In case the rotor blocks suddenly, torque levels up to **16000 Nm** can occur which need to be absorbed by the system and the high vacuum flange.
- For installing the turbomolecular pumps to the high vacuum flange, the components listed in the following **must** be used exclusively. Otherwise the turbomolecular pump may twist or tear off. The clamps, bolts, nuts and centering rings are special designs from Pfeiffer Vacuum.
- The minimum strength of 170 N/mm<sup>2</sup> of the flange material needs to be observed.

Installation is done as follows:

## ISO-K

For installing an ISO-K to an ISO-K flange the following components are available.

Connection nominal-diameter	Designation	Order-number
DN 200 ISO-K	bracket screws (24 pieces must be used)	PF 300 110 -T
	Centering ring (coated)	PM 016 220 AU
	Centering ring (coated) with splinter shield	PM 016 221 AU
	Centering ring (coated) with protective mesh	PM 016 222 AU
DN 250 ISO-K	bracket screws (22 pieces must be used)	PF 300 110 -T
	Centering ring (coated)	PM 016 225 AU
	Centering ring (coated) with splinter shield	PM 016 226 AU
	Centering ring (coated) with protective mesh	PM 016 227 AU

### Bracket crew

- A ISO-K flange
- B Bracket screw
- C Centering ring, coated
- D Splinter shield
- E Protective mesh

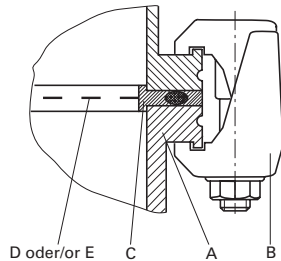

- ➔ The clamps need to be tightened crosswise in three steps. Tightening torque: 5 Nm, 15 Nm, 25 ± 2 Nm.

## Directly Flanging The Pump

The turbopump can be flanged onto the vacuum chamber vertically (up-side down) up to an angle of 90° maximum.



The fore-vacuum flange must always point downwards.

### Permissible installation position

11 Vacuum chamber

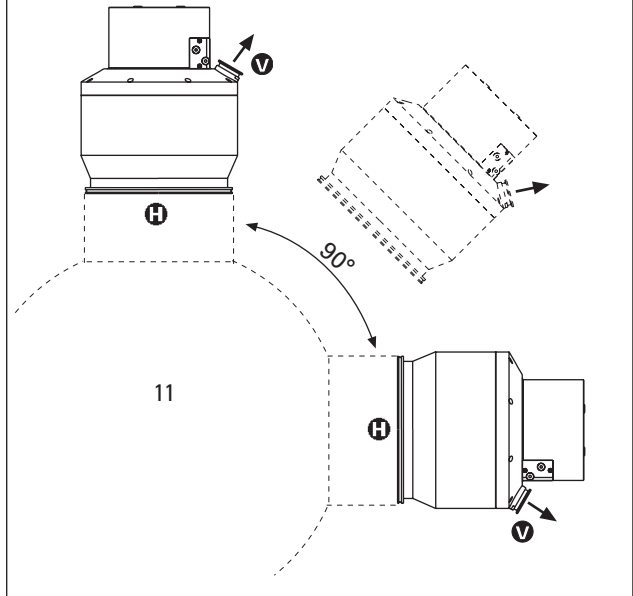

The maximum loading capacity of the high vacuum flange is 2000 N. Asymmetric loading on the high vacuum flange must be avoided.



When operating, a turbopump which has been installed in the upside down position must not be tilted by more than 3° in the opposite direction to the fore-vacuum flange otherwise lubricant is not secured.

### Operating in the upside down position

11 Vacuum chamber

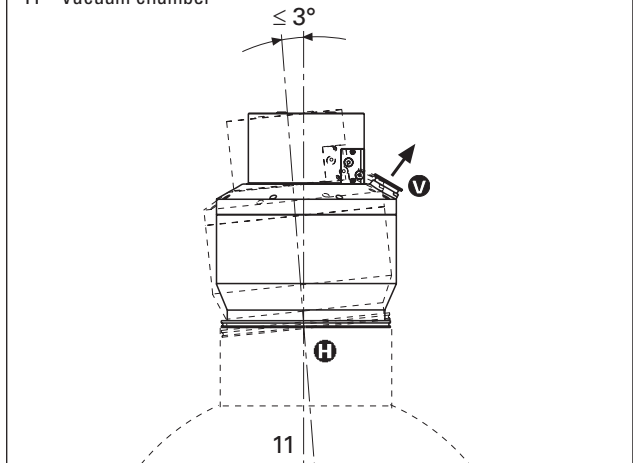

### Horizontal installation position of the turbopump

11 Vacuum chamber

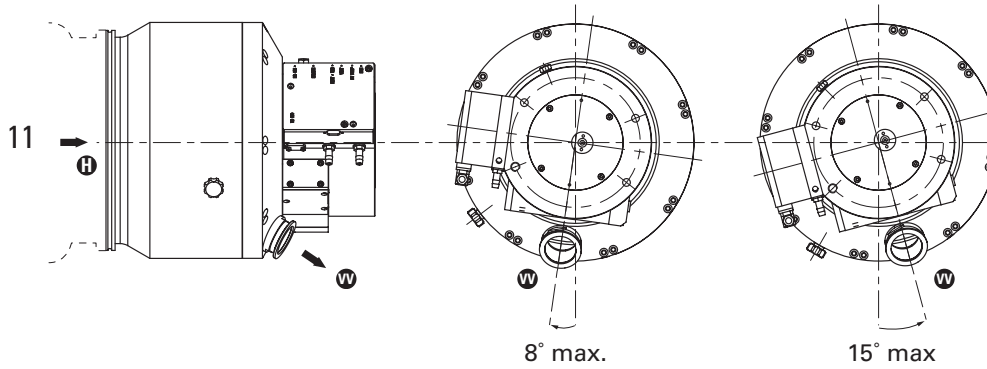

### Horizontal installation position of the turbopump

The fore-vacuum flange of the turbopump must be aligned vertical downwards, otherwise the turbopump could become dirty and the lubricating pump not properly function. The deviation of the fore-vacuum flange from the perpendicular must not exceed the following values (view onto the fore-vacuum side):

Clockwise: 8° max.  
Counter-clockwise: 15° max.



No forces from the piping system must be allowed to act on the pump where turbopumps are anchored.  
Suspend or support all pipes to the turbopump.

### 3.3. Connecting The Fore-Vacuum Side

Backing pump: Fore-vacuum pressure please see "Technical Data"  
Recommendation: Dry Backing Pumps or Rotary Vane Vacuum Pumps from the Pfeiffer Vacuum range.

#### Connecting the backing pump

All connections of the fore-vacuum line: With the usual small flange components or screwed hoses.



Be sure to conduct away the exhaust gases from the backing pump. Do not reduce the free cross section of the fore-vacuum flange with following components.



The exhausted process gases and vapours can represent a health hazard and can also be environmentally damaging.  
Comply with all the gas manufacturer's safety instructions.  
Check the seal of the fore-vacuum line before commissioning.

- ➔ With rigid pipe connections: Fit a bellows in the connecting line to reduce vibration.
- ➔ The fore-vacuum lines should be designed so that they will not break in the event of rotation of the pump at the high vacuum flange.
- ➔ The electrical connection of the backing pump is made via a relay box (please see Section 11. Accessories) whose

### 3.4. Connecting The Cooling Unit

The Turbopumps TPH 2101 U P/TPH 2101 U P C have been designed to be water cooled as standard.  
(cooling water connection please refer to Section 9.1. Dimensions Diagram)



When the turbopump is water cooled the enclosed cover plate for the TC 750 must be installed by an electrical specialist, in order to attain protection class IP 54 (please see Section 3.7.).

#### Water Cooling

The cooling water can be drawn either

- from the cooling water mains, or
- from Recycled Water Cooling Unit TZK in closed circuit.

#### Cooling from the cooling water mains

To prevent deposits collecting in the pump the cooling water must be filtered.

#### Minimum cooling water requirements:

Mechanically clean, optically clear, no turbidity, no sediment, chemically neutral, temperature >dew point.

Oxygen content:	max. 4 mg/kg
Chloride content:	max. 100 mg/kg
Carbonate hardness:	max. 10 ° dH
Consumption of potassium permanganate:	max. 10 mg/kg
Carbon dioxide:	Undetectable
Ammonia:	Undetectable
pH-value:	7 – 9
Max. fore-line overpressure:	max. 6 bar
Minimum flow rate at gas load max.:	100 l/h at 15 °C

#### Connection to the cooling water mains

- ➔ Fit the dirt trap (Accessory) in the supply line.
- ➔ Connect the supply line with hose clips onto one of the two cooling water connections.
- ➔ Connect the return line to the other cooling water connection of the turbopump.
- ➔ Tighten cooling water connection to a torque of 10 Nm.
- ➔ Tighten all hose clips and check for firm seating of the hoses.

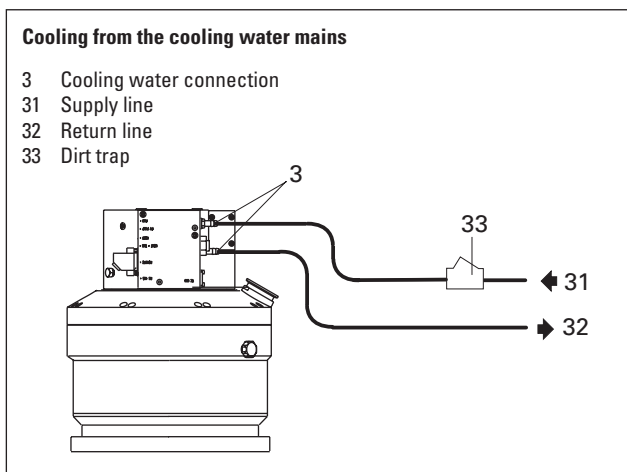

### Cooling with the Recycled Water Cooling Unit TZK (Accessory)

#### Connection to the TZK

Dirt traps are impermissible in the lines.

All other steps as for connecting to the cooling water mains.

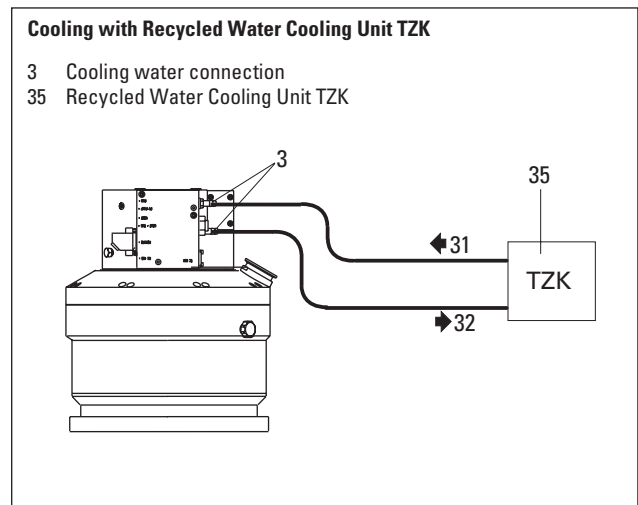

### 3.5. Connecting The Electronic Drive Unit TC 750



The turbopump and the Electronic Drive Unit TC 750 are connected and together form a single unit.  
The connecting cable 8a has to be ordered separately in the required length (see Section 11. Accessories).

- ➔ Unscrew screw with tooth lock 8c from the TC 750 (above the connection X4)<sup>1)</sup>.
- ➔ Plug the plug X4 on connecting cable 8a into the connection X4 on the TC 750 and screw in screw 8b.
- ➔ Secure plug X4 on the TC 750 with a screw and tooth lock 8c<sup>1)</sup>.
- ➔ Connect plug X2 on connecting cable 8a with Power Supply TPS 600/DCU 600 ("Accessories") on connection X2.
- ➔ Using screws and toothlock 8c (two pieces, included with the cable consignment) secure plug X2 to power supply 105<sup>1)</sup>.



Once operations voltage has been supplied, the TC 750 performs a self test on the supply voltage. The supply voltage for the turbopumps is 140 VDC  $\pm$  5% in accordance with EN 60 742.

If the turbopump is to be operated with the Display and Operating Unit DCU 001/DCU 600 or HPU 001, the remote plug 8d on the TC 750 should be disconnected and then proceed in accordance with the respective operating instructions.

1) Only with cable PM 051 843 -T (please see Section 11.)

### 3.6. Installing The Power Supply



Voltage may only be supplied with the Pfeiffer Vacuum power supplies (please see Section 11. Accessories).  
The use of other power supplies requires the prior agreement of the manufacturer and equalization with the valid specification (power supply specifications available on request).



Operations with TPS 600/DCU 600 are only possible in the connection voltage range 185-265 V AC.  
For operations in the connected voltage range 90 - 132 VAC please refer to Operating Instructions "Pumping Operations With DCU", PM 0547 BN.

Please refer to Operating Instructions PM 0521 BN for details on Power Supply TPS 600.



The mains connection must be freely accessible at all times.

#### Connecting the TC 750 with Power Supply TPS 600/DCU 600

- X1 Mains connection
- X2 Connection, Power Supply TPS 600
- X4 Connection TC 750
- S1 ON/OFF switch
- 8 Electronic Drive Unit TC 750
- 8a Connecting cable, TC 750 – TPS/DCU
- 8b Screw
- 8c Screw with tooth lock (2 pieces)
- 8d Remote plug
- 105 Power Supply TPS 600

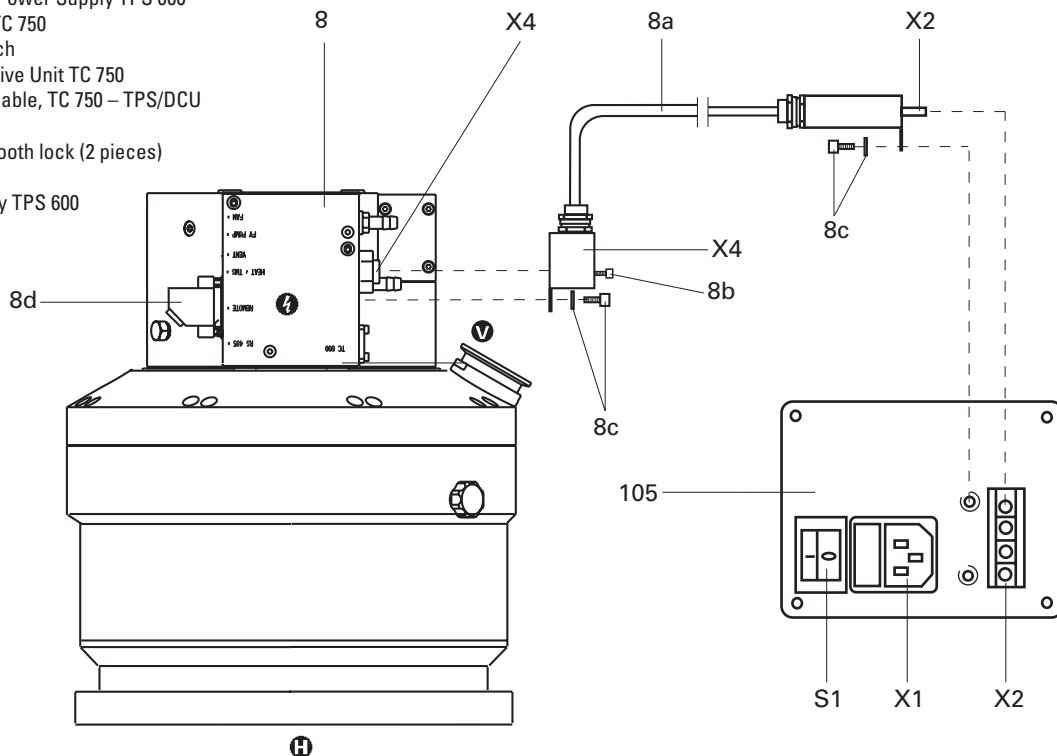

### 3.7. Installing The Cover Plate For The TC 750

The turbomolecular pump with integrated Electronic Drive Unit TC 750 has an IP 30 protection class rating.

When the turbopump is water cooled the enclosed cover plate for the TC 750 **must** be installed by an electrical specialist, in order to attain protection class IP 54



**WARNING** Before installing the cover plate, the Electronic Drive Unit TC 750 must be disconnected from the power supply. The speed of the turbomolecular pump must be 0 Hz.



**PLEASE NOTE** Before beginning with any installation work involving the cover plate for the Electronic Drive Unit TC 750, the remote plug 8d (see Section 3.6.) must be removed. When using the remote plug, the cover of the remote plug must be unscrewed from the remote plug.

- ➔ First the cable clamp must be removed from the TC 750.
- ➔ Thereafter unscrew the 3 cylinder head screws with slot (M3) from the TC 750.
- ➔ Stick on the enclosed sealing to the bottom section 107a.
- ➔ Bolt the bottom section 107a to the TC 750 with the hexagon socket screws 107b (3 pieces). The sealing surface must rest against the TC 750.
- ➔ Insert the O-ring 107c into the bottom section.

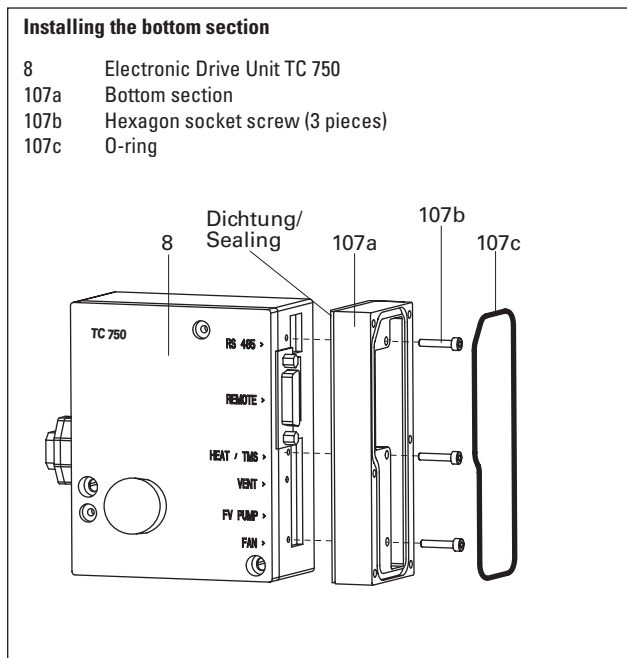

- ➔ First pull the corresponding cables through the inserts with screwed cable glands and the cover 107d and insert the cables at the TC 750.
- In case the pump is operated using the remote control, the remote control unit must be connected in accordance with Section 3.10. and the connections diagram (Section 3.12).

#### Inserts and Screw fittings

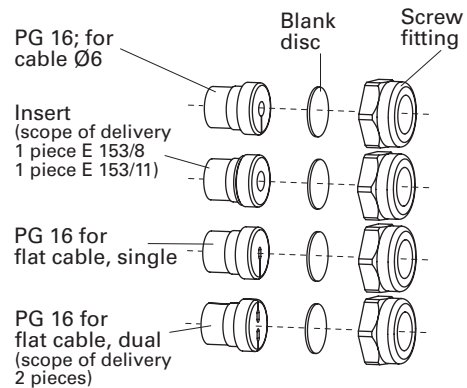

#### The cable arrangement is as follows:

- Accessories (venting valve, backing pump) in PG 16 with flat cable (single or dual)
- Interface cable RS 485 in PG 16; for cable dia. 6
- Connecting cable for remote control etc. in insert E 153/8 or E 153/11.

- ➔ Thereafter screw the cover 107d to the bottom section 107a with the screws 107e (6 pieces). Particularly ensure that the O-ring 107c is properly seated!

#### Installing the cover

- 8 Electronic Drive Unit TC 750
- 107a Bottom section
- 107c O-ring
- 107d Cover
- 107e Screw (6 pieces)

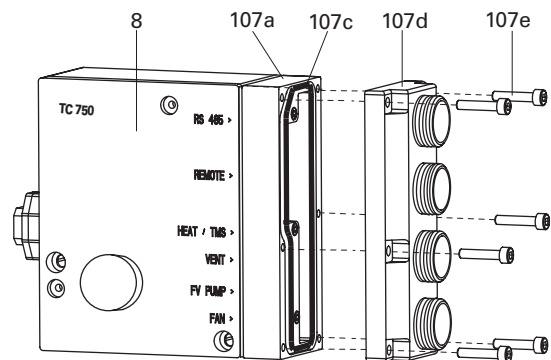

- ➔ Firmly tighten the screwed cable glands at the cover 107d.



**PLEASE NOTE** If a cable feedthrough remains unoccupied, a blank disc must be inserted instead of the cable.

After installing the cover plate, the requirements of protection class IP 54 are fulfilled. The turbomolecular pump may then be operated once more.

### 3.8. Connecting The Venting Valve

The venting valve (see Section 11. Accessories) provides automatic venting in the event of a power failure and switching off.

#### Fitting the venting valve

- ➔ Unscrew the venting screw 4 (see Section 2.1.) from the venting connection of the turbopump.
- ➔ Screw in venting valve 42 with seal (USIT ring) on hexagonal SW 14.

#### Electrical connection

- ➔ Plug control lead 42a into the connection "VENT" of the TC 750 (8) on the turbopump.

Release for venting is executed via remote plug pin 2 (pre-set on delivery, please see Section 4.9.).

The venting mode of the venting valve is selected via the DCU or Serial Interface RS 485.

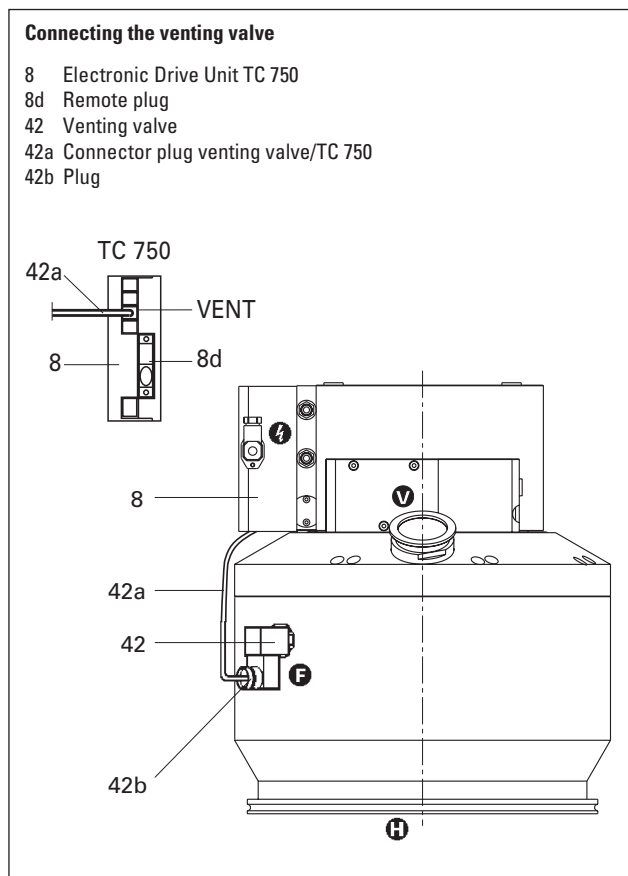

The maximum pressure at the venting valve is 1.5 bar absolute.

Please refer to Operating Instructions PM 0507 BN for details on Venting Valve TVF 005.

### 3.9. Connecting The Sealing Gas Valve

For protection purposes the turbopump should be operated with sealing gas, particularly where corrosive and dusty processes are involved.

Even in non-corrosive processes, from 50% of the maximum gas load sealing gas should be used to ensure rotor cooling.

Connection is made via the sealing gas valve (please see Section 11. Accessories).

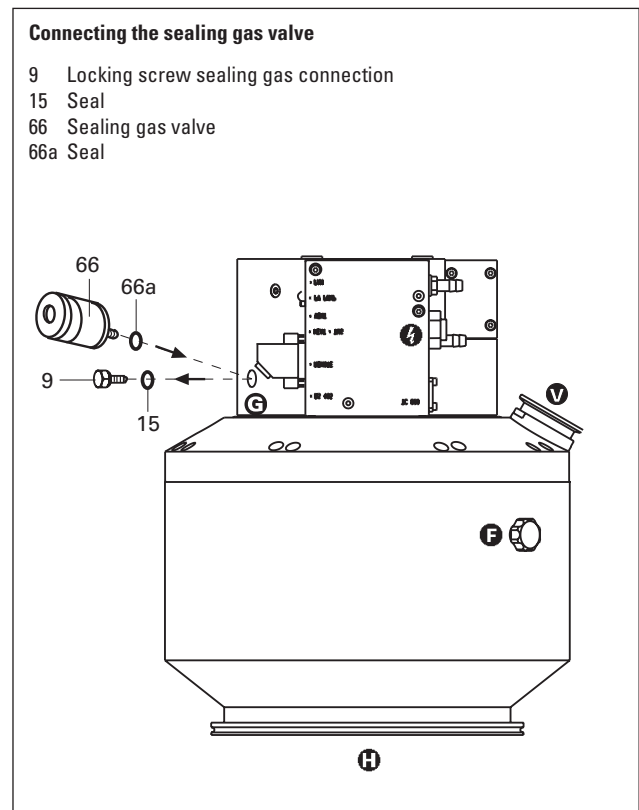

Please refer to Operating Instructions PM 0229 BN for details on installing the sealing gas valve and adjusting the sealing gas flow.

### 3.10. Connecting The Remote Control Unit

Remote control options for various functions are provided with the connection "REMOTE" on the TC 750 via the 15-pole D-Sub-Connector. Shielded cable must be used. Shielding is on the plug side of the TC 750 connected to the TC casing.

The inputs 2-6 are activated by connecting them to the + 24 V on pin 1 (active high) (please see Section 3.12. Connection Diagram).

**Pin occupancy and remote plug functions**  
(please see following table).

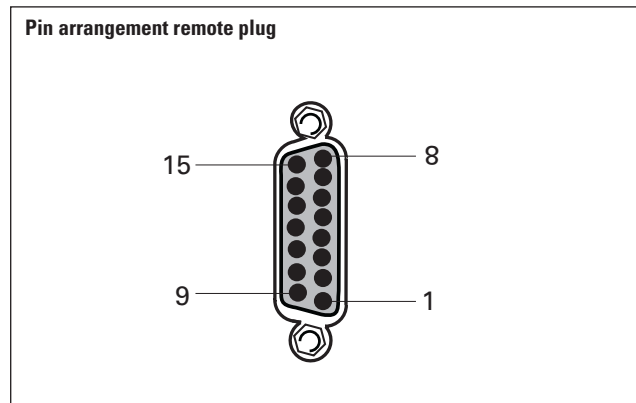

When connecting supply voltage, the turbopump is started.

**On delivery:**  
**Pin 1, Pin 2, Pin 3 and Pin 4 are bridged in the mating plug.**

Pin occupancy and remote plug functions		
Pin nr.	Input open (low)	Input closed (high) on + 24V (pin 1)
1	+24 V	
2	venting blocked (see Section 3.8.)	venting released (see Section 3.8.)
3	motor, turbopump off	motor, turbopump on: the turbopump is driven, current flows through the motor coils
4	pumping station off	pumping station on: the turbopump is driven, backing pump is started via the relay box
5	heating off  optional: sealing gas valve off <sup>1)</sup>	heating on: the heating is switched on once the rotation speed switchpoint is attained and off when the rotation speed switchpoint is unattained optional: sealing gas valve on <sup>1)</sup>
5		reset: by supplying a pulse (T < 2s) with an amplitude of 24V a malfunction acknowledgement can be processed
6	standby off	standby on: pump is accelerated to 66% of its nominal rotation speed
7	rotation speed setting mode off	the rotation speed can be changed by feeding a PWM signal to this pin or via Serial Interface RS 485 (see Section 4.9. "Rotation Speed Setting Mode")
8	<b>Output (low)</b> rotation speed switchpoint not attained	<b>Output (high)</b> rotation speed switchpoint attained; output can be loaded with 24 V/50 mA
9	<b>Output (low)</b> Collective malfunction message	<b>Output (high)</b> malfunction-free operations; output can be loaded with 24 V/50 mA
10	Mass (ground)	_____
11	Contact Output 1: Switchpoint attained	contact <sup>2)</sup> between pin 11 and pin 12 closed if the turbopump is above the switchpoint
12	Contact Output 1: Switchpoint attained	
13	Contact Output 2: Collective malfunction message	contact <sup>2)</sup> between pin 13 and pin 14 open in the event of a collective malfunction
14	Contact Output 2: Collective malfunction message	
15	Analog output	rotation speed proportional output voltage 0 - 10 VDC = 0 - 100 % * fend/load R ≥ 10 kΩ

1) The Option must be set via the Serial Interface RS 485.

(see Operating Instructions PM 0547 BN, Pumping operations with DCU)

2) The following technical data is applicable for the contacts:

$U_{max} = 50 \text{ VDC}$   
 $I_{max} = 1 \text{ A}$

### 3.11. Connecting The Serial Interface RS 485

An external operating component (DCU 001, DCU 600 or HPU 001) or – using a level converter – an external computer can be connected via the connection "RS 485" on the TC 750 with the use of a shielded 8 pole modular connecting cable contained with the delivery.

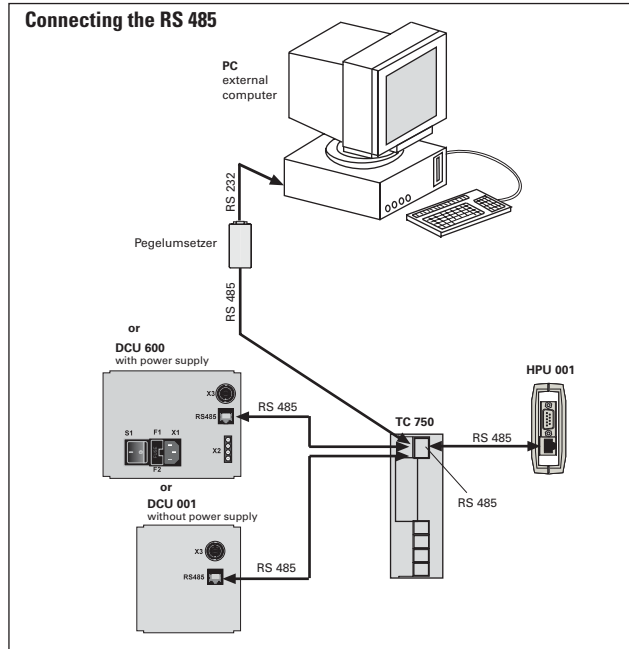

The serial interface is galvanically and safely separated from the maximum supply voltage from the TC 750.

#### Connection

Description	Value
Serial Interface Type:	RS 485
Baud rate:	9600 baud
Data file word length:	8 bit
Parity:	no (no parity)
Start bits:	1
Stop bits:	1..2

The electrical connections are internally optically decoupled.

PIN	Arrangement
1	not connected
2	+24V output ( $\leq 210$ mA loading capacity)
3	not connected
4	not connected
5	RS 485: D+ (DO / RI)
6	Gnd
7	RS 485: D- ( $\overline{DO}$ / $\overline{RI}$ )
8	not connected

RS 485



1 ... 8

(View from the plug side of the TC 750)



It is possible to connect an RS 232 (e.g. PC) via a level converter (please see Section 11. Accessories).

### Connecting The RS 485

#### Connecting to a fixed bus system:

- ➔ Connect all units with D+ (pin 5/RS 485) and D- (pin7/RS 485) to the bus.
- ➔ The bus must be completed at both ends.

The connections should be made in accordance with the specification of the Serial Interface RS 485.

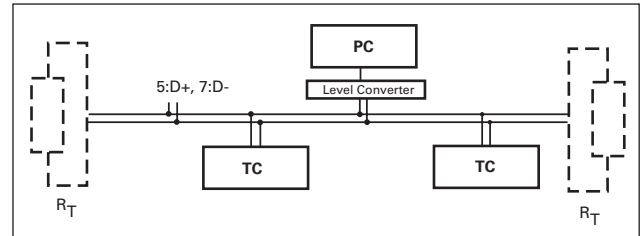

All units connected to the bus must have differing serial interface addresses (parameter 797). The group address of the TC 750 is 960.



Only safety low voltages (SELV) may be connected to Serial Interface RS 485 .

All switched on remote functions have priority over the serial interface functions.



Please refer to the separate Operating Instructions PM 0488 BN for more detailed information on operations via Serial Interface RS 485 and its electronic data.

Profibus DP Gateway TIC 250 is available (accessory) for connecting an Electronic Drive Unit TC 750 to a Profibus DP. Please refer to the respective Operating Instructions PM 0599 BN for detailed information on the operation of the TIC 250.

### 3.12. Connections Diagram

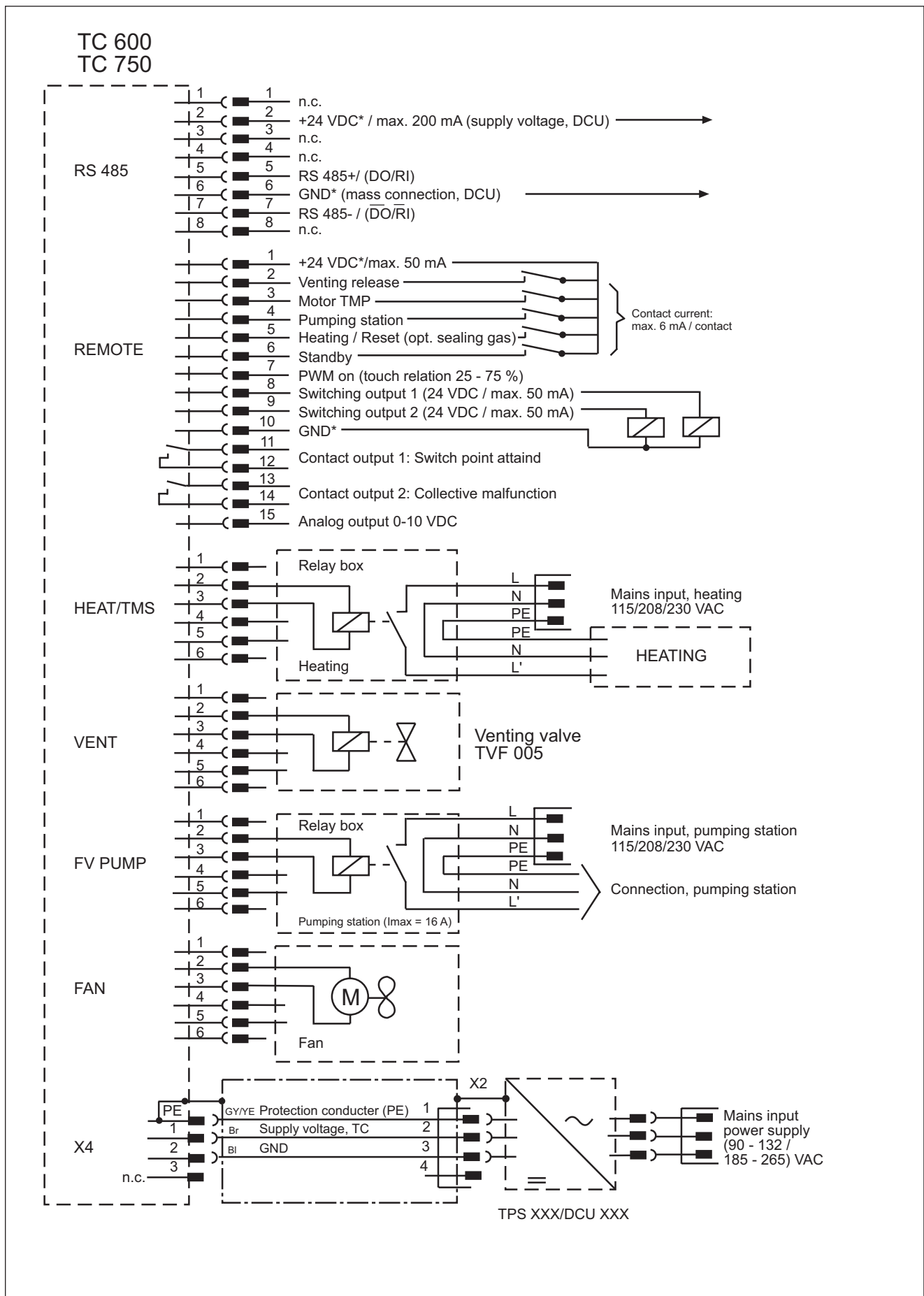

## 4. Operations

### 4.1. Filling In The Lubricant



Pumps must be filled with lubricant before being operated.

If possible fill in the lubricant in the fitting position of the pump.

Pumps are designed to operate with Lubricant "F3" contained with the delivery 40 ml (see type plate).



If "F3" is heated above 300 °C, toxic vapours which can harm the airways are given off. Do not allow "F3" to come into contact with tobacco products (danger of poisoning when ignited). The precautions necessary in the handling of chemicals must be observed.

#### Filling in the lubricant

- ➔ Unscrew lubricant filler screw 71 and, using the syringe provided, inject approximately 40 ml of lubricant.



Where the set-up position is vertical or horizontal the maximum lubricant level in the sight glass is the lower edge of lubricant filler screw 71.

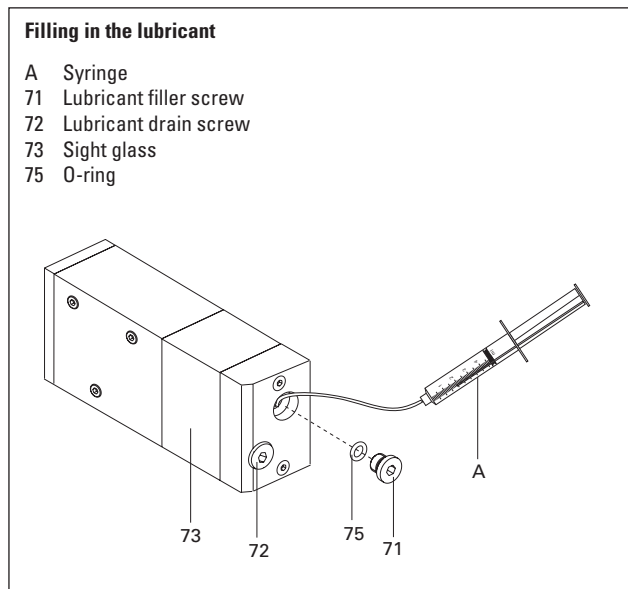

- ➔ Screw back in lubricant filler screw 71 with the O-ring 75.



It is essential to ensure that the lubricating pump is not over-filled with lubricant. Overfilling will cause the excess lubricant to be secreted from the hole for the lubricant filler screw 71.

If necessary, dismantle the lubricating pump from the pump and fill up with lubricant (please see Section 8.1).

### 4.2. Before Switching ON

Sections 4.2 to 4.6. refer only to operating the pump in its condition on delivery, without the DCU/HPU display and operating unit. The bridges "venting release", "motor, TMP ON" and "pumping station ON" are fitted in the remote control plug.

The pump starts automatically once voltage is supplied.

Please refer to Section 4.8. regarding the switching on with the Display And Operating Unit DCU 001/DCU 600 or HPU 001.



Turbopump rotors rotate at high speed. When the high vacuum flange is open there is a danger of injury and of damage to the pump caused by objects falling into the pump. Therefore never operate the pump with open high vacuum flange!



Take care when pumping hazardous gases and observe the safety precautions of the gas manufacturer!

- ➔ With sealing gas: Open the sealing gas supply.
- ➔ Open cooling water supply and check flow.
- ➔ Plug connecting cable 8a (see Section 11. Accessories) into the TC 750 and connect with Power Supply TPS 600 on X2 (please see Section 3.5.).



The following pre-settings have been programmed:

– Start-up time	11 min
– Rotation speed switchpoint	80%
– Automatic venting	50%

These settings can only be altered via Serial Interface RS 485 (DCU, HPU or PC); please refer to the respective operating instructions.

### 4.3. Switching ON

- ➔ Switch on the turbopump with switch S1 on the power supply.
- Once the self test has been successfully completed on the TC 750 (duration approximately 30 seconds), both the turbopump and the backing pump (if connected) begin operating.

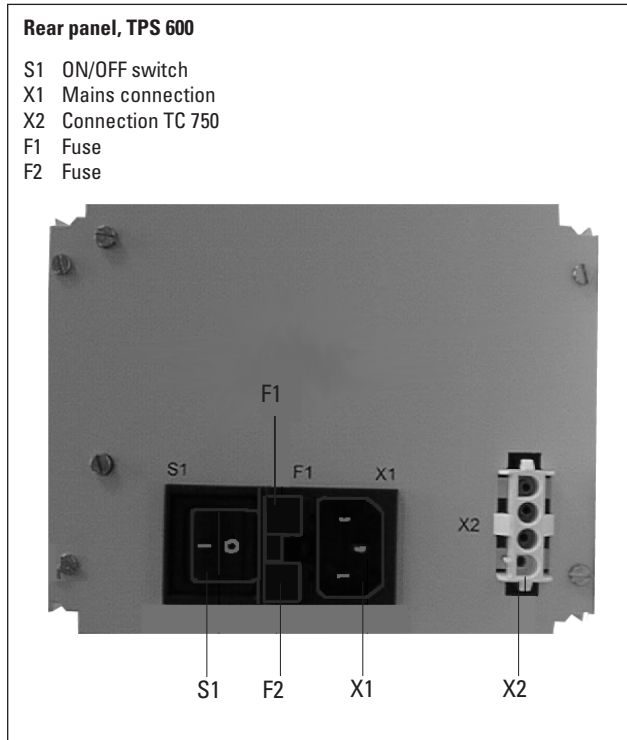

**PLEASE NOTE** When the unit is switched on for the first time or after a lubricant change the contact to the lubricating pump can open as a result of the degassification of the lubricant. In such cases, as for other malfunctions, the electronic drive unit shuts down the turbopump.

- ➔ The turbopump must be re-started with switch S1 on the power supply.

### 4.4. Gas Type Dependent Operations

**CAUTION** Water cooling is required if the pumps are to be operated with gas load.

Where high level gas loads and rotation speeds are involved, the resulting friction subjects the rotor to the effect of great heat. To avoid over-heating, a power rotation speed characteristic line is implemented in the TC 750; this ensures that where maximum gas loads are involved, the pump will operate at any rotation speed without the danger of damage arising.

The maximum power is dependent on the type of gas. Two characteristic lines are available for any type of gas in order to fully exploit the power potential of the pump:

- "Gas Mode 0" for gases with molecular mass  $\geq 40$  as, for example, Argon;
- "Gas Mode 1" for all lighter gases.

Works setting: "Gas mode 0"

- ➔ Set the applicable gas mode on the TC 750 via the DCU or HPU (please refer to the respective operating instructions).



**WARNING** Pumping gases with molecular mass  $\geq 40$  with the incorrect gas mode can cause damage to the pump. When pumping noble gases heavier than Argon it can come to the destruction of the pump. Please contact the manufacturer before using such gases.

For the vertex of the power characteristic line please refer to Section 9. Technical Data.

Maximum power is applied when the pump starts in order to limit the time required. Once the set rotation speed is attained, switching to the selected power characteristic line is automatic.

If the gas dependent maximum power is exceeded, the rotation speed is reduced until equilibrium between the permissible power and gas friction is attained. The power limitation serves to protect the pump against thermal overloading. In order to avoid rotation speed fluctuations it is recommended to set, in rotation speed setting mode, the equilibrium frequency or a somewhat lower frequency.



**PLEASE NOTE** There can be types of pump whereby there is no differentiation between the two "gas modes" settings.

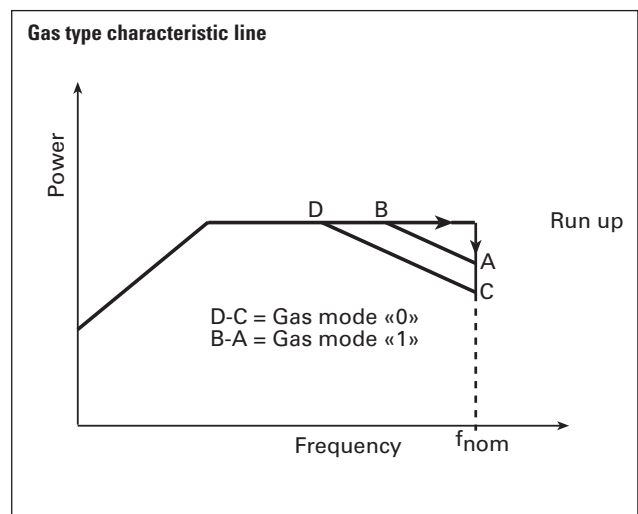

## 4.5. Circulatory Lubrication

The ball bearing on the fore-vacuum side is supplied with lubricant via the lubricating pump.

The circulation of the lubricant is monitored via a switching contact. If there is insufficient lubricant, the electronic drive unit switches off the turbopump. Monitoring is active only from 60% of the final rotation speed.

If, at a rotation speed of > 60% of the final rotation speed (for example through the degassification of the lubricant), the contact opens for  $\geq 2$  minutes, the electronic drive unit assumes a lubricant deficiency and switches off the turbopump.



In rotation speed setting mode with set speed below 60% of the rated rotation speed the pump is first accelerated to 60% and then adjusted to the selected rotation speed.

- ➔ Check the filling level of the lubricant.
- ➔ Re-start the turbopump with switch S1 on the power supply.

## 4.6. Switching OFF And Venting

To avoid contamination occurring when switching off, the pump should be vented before shut-down.

- ➔ Switch off both turbopump and backing pump on the power supply at the same time with switch S1. Where corrosive gas processes are involved, the sealing gas supply should be shut off after approximately 10 minutes and both turbo pump and backing pump switched off with switch S1.
- ➔ Venting  
There are three possibilities to vent turbopump:
  - **Manual venting** with the use of the venting screw (status on delivery).
  - **Venting with the venting valve** TVF 005 (see Section 11. Accessories) which is selectable via the remote control (please see Section 4.9.), or via the DCU/HPU (see respective operating instructions).
  - **Venting in two stages** when the vacuum chamber should be vented as quickly as possible.  
First stage: venting with a pressure increase rate of 15 mbar/s for 20 seconds.  
Second stage: venting with an optionally large venting valve.  
The valve cross-section for a venting rate of 15 mbar/s must be compatible with the size of the vacuum chamber. Where small vacuum chambers are involved, the Pfeiffer Vacuum Venting Valve TVF 005 can be used for first stage venting.
- ➔ Shut off water supply.

## 4.7. Shutting Down For Longer Periods



Vacuum pumps are sometimes used to pump aggressive or hazardous gases. There is a danger of personal injury resulting from coming into contact with process gases. Before removing a turbopump from the system, first:

- Vent the turbopump with a neutral gas or dry air.
- Ensure that there is no residual process gas in the system nor in the feeder lines.

If the turbopump is to be shut down for more than **a year**:

- ➔ Remove turbopump from the system.
- ➔ Change the lubricant (see Section 8.1.).
- ➔ Close the high vacuum flange and evacuate the turbopump via the fore-vacuum flange.
- ➔ Vent turbopump via the venting connection with nitrogen or dry air.
- ➔ Close fore-vacuum and venting connection by blank flanging.
- ➔ Place the pump vertically on the high vacuum flange.
- ➔ The pump must be stored in buildings within a temperature range of -25 °C to +55 °C.
- ➔ In rooms with moist or aggressive atmospheres, the turbopump must be air-sealed in a plastic bag together with a bag of dessicant.



If the pump has been shut down for **3 years** a bearing change must be carried out (please get in touch with Pfeiffer Vacuum Service).

## 4.8. Operations With The DCU 001/ DCU 600 or HPU 001

Operations with the DCU 001 or DCU 600 or HPU 001 should be carried out in accordance with the relevant Operating Instructions:

PM 0477 BN "DCU description" and.  
PM 0547 BN "Operating the pump with the DCU",  
PT 0101 BN "Display and Operating Unit HPU 001".



Operations with the DCU 001/DCU 600, the remote plug 8d on the Electronic Drive Unit TC 750 should be disconnected (please see Section 3.5.).

## 4.9. Operations With The Remote Control Unit

Remote control operations can be performed via the connection with the designation "REMOTE" on the TC 750.

The connection is via a 15 pole D-Sub connector.

Pin arrangement and remote plug functions please see table under Section 3.10..

Inputs 2-6 are activated if they are connected with the +24 V on pin 1 (active high).



**On delivery there is a bridge between pin 1, pin 2, pin 3 and pin 4 on the TC 750 mating plug.** When operations voltage is supplied and a successfully completed TC 750 self-test the turbopump and any connected backing pump will be started.

### Venting Release (Optional)

**Automatic venting:**  
(works setting on the remote plug pin 2 high)

Venting frequency	Switch off the pumping station	Mains power failure <sup>1)</sup>
< 330 Hz (correspond to 50% of the final rotation speed)	venting valve opens for 3600 s (1 h) (works setting)	venting valve opens and closes on attainment of approximately 15% of the final rotation speed

1) When mains power is restored the venting procedure is interrupted.

**Venting OFF (works setting on the remote plug pin 2 low):**

Venting does not take place.

**Other venting modes:**

Other venting modes can be selected via the DCU or HPU.

### Motor, Turbopump

When the pumping station is switched on and once the self test has been successfully completed (duration approximately 30 seconds), the turbopump is set in operation.

During operations, the turbopump can be switched on and off while the pumping station is switched on.

Thereby the turbopump will not be vented.

### Heating/Reset

**Heating (optional)**

Once the rotation speed switchpoint is attained the heating unit is switched on; when the rotation speed switchpoint is fallen below the heating unit is switched off.

**Reset**

The heating input has two functions (please see Section 3.10., point 5 "Reset").

### Standby

The pump can be operated optionally at 66% of its nominal rotation speed (standby ON) or at its nominal rotation speed (standby OFF).

### Pumping Station

Any connected pumping station components are started up (e.g. backing pump, venting valve, air cooling) and with simultaneous activation of the input "motor, turbopump" the turbopump is set in operation once the self test has been successfully completed (duration approximately 30 seconds).

### Rotation Speed Setting Operations Via Input PWM

The supply of pulse width modulated signals (PWM) with a ground frequency of 100 Hz  $\pm 20\%$  with an amplitude of maximum 24 V and a touch ratio of 25-75% enables the rotation speed to be set in the range from 50-100% of the nominal rotation speed.

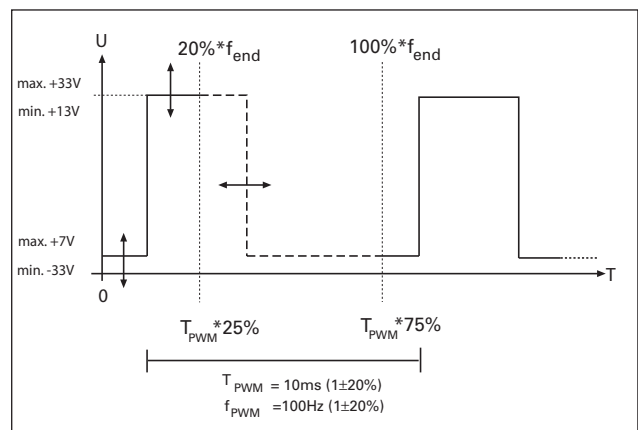

If no signal is present the pump runs up to its final rotation speed.

**Available as accessories (please see Section 11.):**

- A PWM adapter box for rotation speed setting operations for the turbopump.
- A Brake Unit TBU 600 which enables, in rotation speed setting mode, faster braking on turbopumps with TC 750.

### Switching Outputs

Switching outputs 1 and 2 can be loaded with a maximum 24 V / 50 mA per output. The following functions are assigned to the switching outputs:

**Switching output 1:** Active high when the rotation speed switchpoint is attained. The switchpoint for the turbopump is set at 80% of the nominal rotation speed. It can be used, for example, for a message "pump ready to operate".

**Switching output 2:** Active low with a malfunction - collective malfunction message

The connection of a relay is made between pin 10 (mass) and the respective switching output pin 8 or pin 9 (see Section 3.12. Connections Diagram).

# 5. Monitoring Operations

## 5.1. Operations Display Via LED

Certain operations modes of the turbopump and the TC 750 can be ascertained via the two integrated LEDs located on the front panel of the TC 750.

The following operations modes are displayed:

LED		Cause
green	red	
glows		<ul style="list-style-type: none"> <li>– Power supply OK</li> <li>– Function "pumping station ON" carried out</li> </ul>
flashes (1/12 s active)		<ul style="list-style-type: none"> <li>– Power supply OK</li> <li>– Pumping station OFF</li> </ul>
blinks (1/2 s active)		<ul style="list-style-type: none"> <li>– Mains power supply failure</li> </ul>
	glows	<ul style="list-style-type: none"> <li>– Collective malfunction (for example, start-up time error, excess temperature, turbopump or TC 750, lubricant deficiency)</li> <li>– Switching output 2 active (low)</li> </ul>
	blinks (1/2 s active)	<ul style="list-style-type: none"> <li>– Warning (for example, earth leakage fault in the voltage supply, mains power supply failure)</li> </ul>

## 5.2. Turbopump Temperature Monitoring

Where impermissible motor temperatures are involved or the temperature of the casing is too high, the motor current is reduced. This can lead to dipping below the set rotation speed switchpoint and results in the turbomolecular pump being switched off.

LED on the TC 750 glows red: Collective malfunction.



Differentiated malfunction and warning signals are only possible with the use of the DCU or HPU.

## 6. What To Do In Case Of Breakdowns?

Problem	Possible Causes	Remedy
Pump doesn't start; None of the integrated LEDs glow on the TC 750	<ul style="list-style-type: none"> <li>• Power supply interrupted</li> <li>• Incorrect operations voltage supplied</li> <li>• Pins 1-3 and 1- 4 on the remote-plug not connected</li> <li>• No supply of operations voltage</li> <li>• Defect TC 750</li> <li>• Reduction in the voltage in the cable</li> </ul>	<ul style="list-style-type: none"> <li>• Check fuse in the power supply</li> <li>• Check plug contacts on the power supply</li> <li>• Check power supply feeder line</li> <li>• Check voltage on the power supply (140 DC) at connection X2</li> <li>• Supply correct operations voltage</li> <li>• Connect pins 1-3 and 1- 4 on the remote plug</li> <li>• Check plug contacts on the power supply</li> <li>• Replacing the TC 750 (see Section 8.4.)</li> <li>• Use suitable cable</li> </ul>
Pump doesn't attain nominal rotation speed within the set start-up time; Pump cuts out during operations	<ul style="list-style-type: none"> <li>• Fore-vacuum pressure too high</li> <li>• Leak or too high levels of gas load</li> <li>• Rotor sluggish caused by defective bearing</li> <li>• TC start-up time too short</li> <li>• Thermal overloading caused by: <ul style="list-style-type: none"> <li>– Insufficient water flow</li> <li>– Insufficient air supply</li> <li>– Fore-vacuum pressure too high</li> <li>– Ambient temperature too high</li> </ul> </li> <li>• Lubricant or lubricating pump dirty</li> <li>• Lubricant deficiency</li> </ul>	<ul style="list-style-type: none"> <li>• Check backing pump function</li> <li>• Check seals</li> <li>• Seek leak and repair</li> <li>• Supply of process gas too high; reduce</li> <li>• Check bearing (noises?): Request Pfeiffer Vacuum Service to replace</li> <li>• Set longer start-up time with the DCU, HPU or PC</li> <li>• Ensure free flow</li> <li>• Ensure adequate air supply</li> <li>• Reduce fore-vacuum pressure</li> <li>• Reduce ambient temperature</li> <li>• Carry out lubricant change as per Section 8.1. or clean the lubricating pump as per Section 8.2.</li> <li>• Check lubricant and replace as necessary</li> </ul>
Pump doesn't attain final pressure	<ul style="list-style-type: none"> <li>• Pump dirty</li> <li>• Leak in vacuum chamber, lines or pump</li> </ul>	<ul style="list-style-type: none"> <li>• Bake out pump</li> <li>• If seriously contaminated: Request Pfeiffer Vacuum Service to clean</li> <li>• Seek leak starting with vacuum chamber</li> <li>• Repair leak</li> </ul>
Unusual operating noises	<ul style="list-style-type: none"> <li>• Bearing damaged</li> <li>• Rotor damaged <ul style="list-style-type: none"> <li>– Foreign particles in the blade area</li> </ul> </li> <li>• Splinter shield (if fitted) not seated firmly</li> </ul>	<ul style="list-style-type: none"> <li>• Inform Pfeiffer Vacuum Service of need for repair</li> <li>• Inform Pfeiffer Vacuum Service of need for repair</li> <li>• Check seat of splinter shield</li> </ul>
Red LED on the TC 750 glows	<ul style="list-style-type: none"> <li>• Collective malfunction</li> </ul>	<ul style="list-style-type: none"> <li>• Reset via mains OFF/ON or remote pin 5</li> <li>• Different malfunction display with a DCU or HPU possible<sup>1)</sup></li> </ul>
Red LED on the TC 750 blinks	<ul style="list-style-type: none"> <li>• Warning from: <ul style="list-style-type: none"> <li>– Mains power failure</li> <li>– Supply voltage short circuit to earth</li> </ul> </li> <li>• Wrong setting for nominal rotation speed (Parameter 777)</li> </ul>	<ul style="list-style-type: none"> <li>• Different warning display with a DCU or HPU possible<sup>1)</sup></li> <li>• Check power supply voltage</li> <li>• Check the power supply mains connection</li> <li>• Check the power supply voltage for short circuit to earth</li> <li>• Enter 525 Hz for parameter 777 (see operating instruction PM 0547 BN "Pumping Operations With DCU"). If there is no DCU/HPU available contact Pfeiffer Vacuum Service .</li> </ul>

1) Without a DCU or HPU inform Pfeiffer Vacuum Service to check the cause of trouble.

## 7. Service

### Do make use of our service facilities

In the event that repairs are necessary a number of options are available to you to ensure any system down time is kept to a minimum:

- Have the pump repaired on the spot by our Pfeiffer Vacuum Service Engineers;
- Return the pump to the manufacturer for repairs;
- Replace the pump.

Local Pfeiffer Vacuum representatives can provide full details.



Please take into account that where Pfeiffer Vacuum Service replacement service is involved the standard operating parameters are always pre-set.

If your application requires different parameters, please modify accordingly.



The turbopump and the Electronic Drive Unit TC 750 form a single unit and must therefore be returned complete for repair purposes. Before returning the unit it should be ensured that the power supply is not the cause of the malfunction.

### Before returning:

- ➔ Dismantle all accessories.
- ➔ If the unit is free of harmful substances please attach a clearly visible notice "Free of harmful substances" (both on the unit and also on the delivery note and any accompanying letters).

"Harmful substances" are substances and preparations as defined in the current, local, dangerous substances regulations; in the U.S.A. as "materials in accordance with the Code of Federal Regulations (CFR) 49 Part 173.240 Definition and Preparation". We will carry out the decontamination and invoice this work to you if you have not attached this note.

This also applies where the operator does not have the facilities to carry out the decontamination work.

### Fill out the declaration of contamination

- ➔ In every case the "Declaration of Contamination" must be completed diligently and truthfully.
- ➔ A copy of the completed declaration must accompany the unit; any additional copies must be sent to your local Pfeiffer Vacuum Service Center.

Please get in touch with your local Pfeiffer Vacuum representatives if there are any questions regarding contamination.



Decontaminate units before returning or possible disposal. Do not return any units which are microbiologically, explosively or radioactively contaminated.

### Returning contaminated units

If contaminated have to be returned for maintenance/repair, the following instructions concerning shipping must be followed:

- ➔ Neutralise the pump by flushing with nitrogen or dry air.
- ➔ Seal all openings to the air.
- ➔ Seal pump or unit in suitable protective foil.
- ➔ Return equipment only in suitable, rugged shipping containers and by complying with the currently valid shipping regulations.



Repair orders are carried out according to our general conditions of sale and supply.

If repairs are necessary, please send the pump together with a short damage description to your nearest Pfeiffer Vacuum Service Center.

## 8. Maintenance/Replacement



No liability for personal injury nor material damage will be accepted for damages and operational interruptions which have been caused by improper maintenance; in addition, all guarantees become invalid.

The bearing should be changed every 3 years (request Pfeiffer Vacuum Service to change). Where extreme operating conditions or unclean processes are involved, the replacement interval should be checked with your Pfeiffer Vacuum Service Center.

You can replace the lubricant, the lubricant pump and the Electronic Drive Unit TC 750 yourself.

Please contact your local Pfeiffer Vacuum Service for all other maintenance and service work.



Ensure no mechanical forces act on the Electronic Drive Unit TC 750.

### 8.1. Replacing The Lubricant

The lubricant should be replaced at least once a year. Where extreme operating conditions or unclean processes are involved, the replacement interval should be checked with your Pfeiffer Vacuum Service Center.



Lubricant screw 72 may only be opened if the turbopump has been vented to atmospheric pressure.



Detach the lubricant pump is required in order to carry out a lubricant change.

- ➔ Switch off the turbopump, vent to atmospheric pressure (see Section 4.6.) and allow to cool as necessary.
- ➔ Remove the lubricant pump from the turbopump as per Section 8.3..
- ➔ Unscrew lubricant drain screw 72 and drain lubricant into a suitable container.



Lubricants can contain toxic substances from the medium pumped. Lubricant must be disposed of in accordance with the respective regulations. Safety instructions data sheet for the lubricant on request.

- ➔ Screw back in the lubricant drain screw 72 with the O-ring 75.
- ➔ Unscrew lubricant filler screw 71. Using the syringe provided inject approximately 40 ml of lubricant as per the type plate (order number for "F3" see Section 11.1.).



Where the set-up position is vertical or horizontal the maximum lubricant level in the sight glass is the lower edge of lubricant filler screw 71.

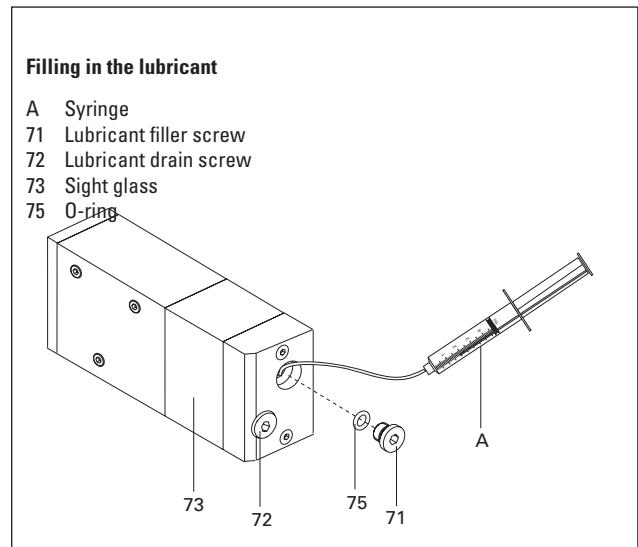

It is essential to ensure that the lubricating pump is not over-filled with lubricant. Overfilling will cause the excess lubricant to be secreted from the hole for the lubricant filler screw 71.

- ➔ Screw in lubricant filler screw 71 with the O-ring 75.
- ➔ Re-fit the lubricant pump to the turbopump.

## 8.2. Cleaning The Lubricant Pump

If, after a malfunction on account of insufficient lubricant, the pump no longer accelerates to the operating rotation speed, the lubricant pump has to be cleaned or replaced (See Section 8.3.).

For cleaning the lubricant pump please contact your local Pfeiffer Vacuum Service.

## 8.3. Replacing The Lubricant Pump

If, after a malfunction on account of insufficient lubricant, the pump no longer accelerates to the operating rotation speed, the lubricant pump has to be replaced as detailed in the following.

Order number for the lubricant pump, see Section 10. Spare Parts.

- ➔ Switch off the turbopump, vent to atmospheric pressure (please see Section 4.6.) and allow to cool as necessary.
- ➔ Unscrew screws 83 (3 pieces) from the lubricant pump 77 and remove the lubricant pump from the turbopump.

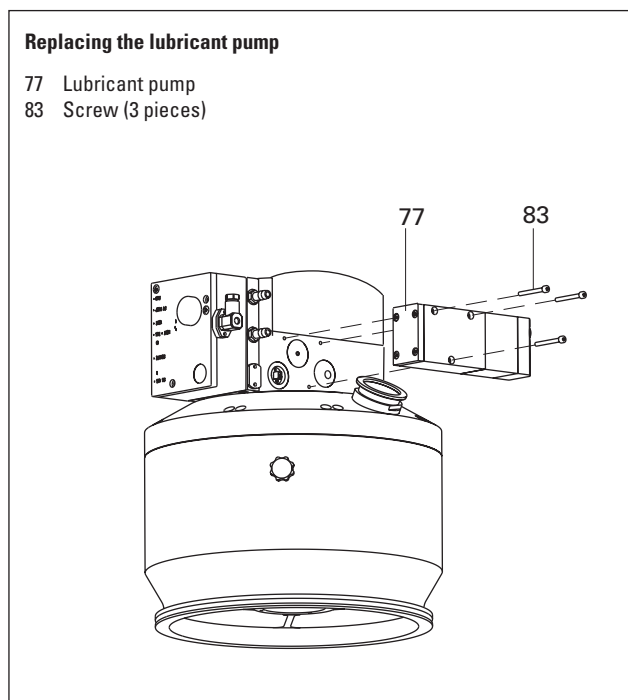

- ➔ Fill in lubricant into the new lubricant pump as detailed in Section 8.1 (order number for "F3" see Section 11.1.).
- ➔ Install the lubricant pump back onto the turbomolecular pump.

## 8.4. Replacing The Electronic Drive Unit TC 750



Turbopump and Electronic Drive Unit TC 750 must only be disconnected from each other when the turbopump is completely at rest and the turbopump has been disconnected from the power supply.

Remove the Electronic Drive Unit TC 750 from the turbopump as follows:

- ➔ If necessary, remove the turbopump from the system.
- ➔ Unscrew screws 8c (2 pieces) from the Electronic Drive Unit 8 and remove the TC 750 from the turbopump.

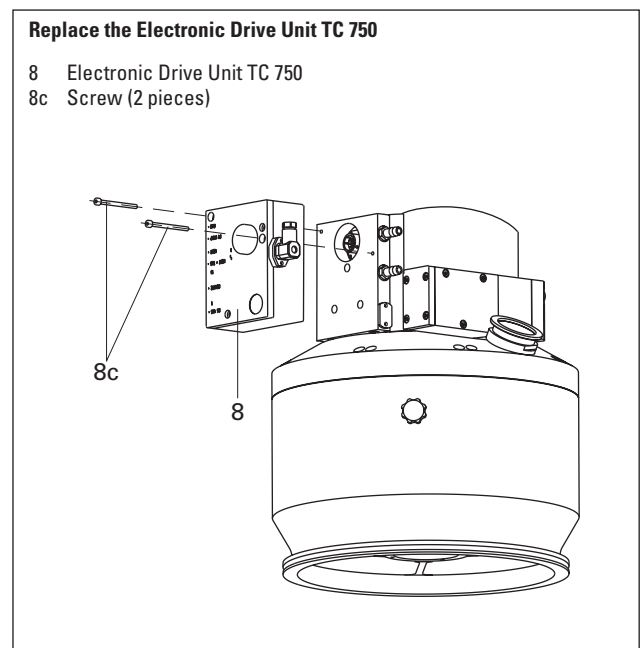

- ➔ Assemble the new Electronic Drive Unit TC 750 (for order number please see Section 10. Spare Parts) on the turbopump and connect again.



Please take into account that after replacement the Electronic Drive Unit TC 750 the standard operating parameters are always pre-set. If your application requires different parameters, please modify accordingly.

## 9. Technical Data

Feature	Unit	TPH 2101 U P	
		TPH 2101 U P C	
Connection nominal diameter:			
Inlet		DN 200 ISO-K	DN 250 ISO-K
Outlet		DN 40 ISO-KF	
Venting connection		G 1/8"	
Nominal rotation speed	Hz (1/min)	525 (31 500)	
Standby rotation speed	Hz (1/min)	350 (21 000)	
Start-up time (up to 90% of the nominal rotation speed fore-vacuum pressure $\leq 0.1$ mbar)	min	8	
Max. noise level <sup>1)</sup>	dB (A)	47	
Final pressure, backing pump	mbar	$\leq 0.2$	
Integral leak rate <sup>2)</sup>	mbar l/s	$< 2 \cdot 10^{-8}$	
Maximum permissible rotor temperature	°C	120	
Permissible heat radiation power	W	80	
Volume flow rate for:			
Nitrogen N <sub>2</sub>	l/s	1400	1900
Helium He	l/s	1700	1900
Hydrogen H <sub>2</sub>	l/s	1650	1850
Compression ratio for:			
N <sub>2</sub>		$> 10^8$	
He		$2 \cdot 10^5$	
H <sub>2</sub>		$3 \cdot 10^4$	
Maximum fore-vacuum pressure			
N <sub>2</sub>	mbar	1.5	
He	mbar	1	
H <sub>2</sub>	mbar	0.5	
Maximum gas throughput <sup>3) 4)</sup>			
with HV pressure of 0.1 mbar			
N <sub>2</sub>	mbar/l/s	approx. 25	
Ar	mbar/l/s	approx. 25	
with nominal rotation speed (water cooling)			
N <sub>2</sub>	mbar/l/s	15.0	15.0
Ar	mbar/l/s	14.5	14.5
with voltage range 90 - 132 VAC			
N <sub>2</sub>	mbar l/s	8.1	8.1
Vertex power characteristics lines <sup>5)</sup>			
A	W / Hz	750 / 525	
B	W / Hz	750 / 525	
C	W / Hz	750 / 525	
D	W / Hz	750 / 525	
Final pressure <sup>6)</sup>			
with rotary vane vacuum pump	mbar	$< 1 \cdot 10^{-7}$	
with UniDry™ 050-4	mbar	$< 1 \cdot 10^{-7}$	
Lubricant			
Type		F3	
Filling volume	ml	40	
Cooling water consumption			
with water at 15 °C <sup>7)</sup>	l/h	100	
Cooling water temperature	°C	5 - 25	
Weight	kg	39	38
Permissible magnetic field	mT	7	
Connection voltage	VDC	140 $\pm$ 5%	
Current consumption	A	5.4	
Power	W	750	
Protection class <sup>8)</sup>		IP 30	
Shipping and storage temperature	°C	-25 bis +55	
Relative humidity	%	5 - 85 non condensing	

1) Distance from the pump 1 m

2) Measured at a helium concentration of 20%, 10 s measurement time

3) If the pump is to be operated with more than 50% of the maximum gas load, sealing gas must be used.

4) Backing pump 120 m<sup>3</sup>/h.

5) For gas typ characteristics lines please refer to Section 4.4.

6) In accordance with DIN 28 428 the final pressure of a turbomolecular pump is that pressure which is attained in a measuring dome 48 hours after baking out.

7) With maximum gas throughput.

8) Protection class IP 54 is afforded for the Electronic Drive Unit TC 750 by installing the provided cover plate (see Section 3.7.).

## 9.1. Dimensions Diagram

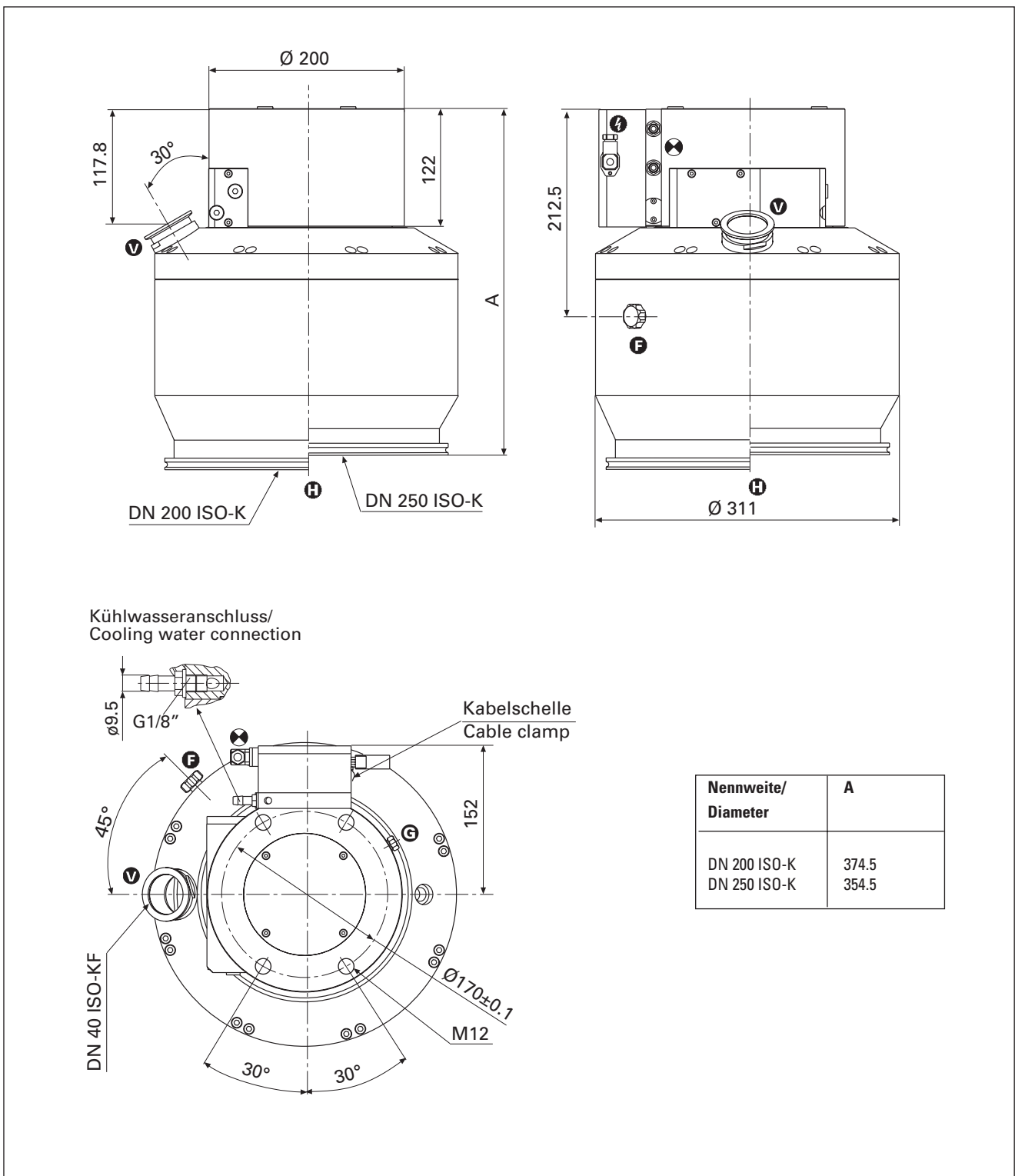

# 10. Spare Parts

Pos.	Description	Pieces	Size	Number	Comments	Ordering Quantity
<b>Spare parts TPH 2101 U P / TPH 2101 U P C</b>						
8	Electronic Drive Unit TC 750	1		PM C01 713	see Section 8.4.	
8d	Remote plug	1		P 0920 668 E		
17	Seal ring for water connection	2		P 3529 133 -A		
71	Lubricant filler screw	1		N 3191 382 X		
72	Lubricant drain screw	1		N 3191 382 X		
75	O-ring	2	6 x 2.2	P 4070 088 PV	see Section 8.3.	
77	Lubricant pump (complete)	1	for F3	PM 083 868 -		

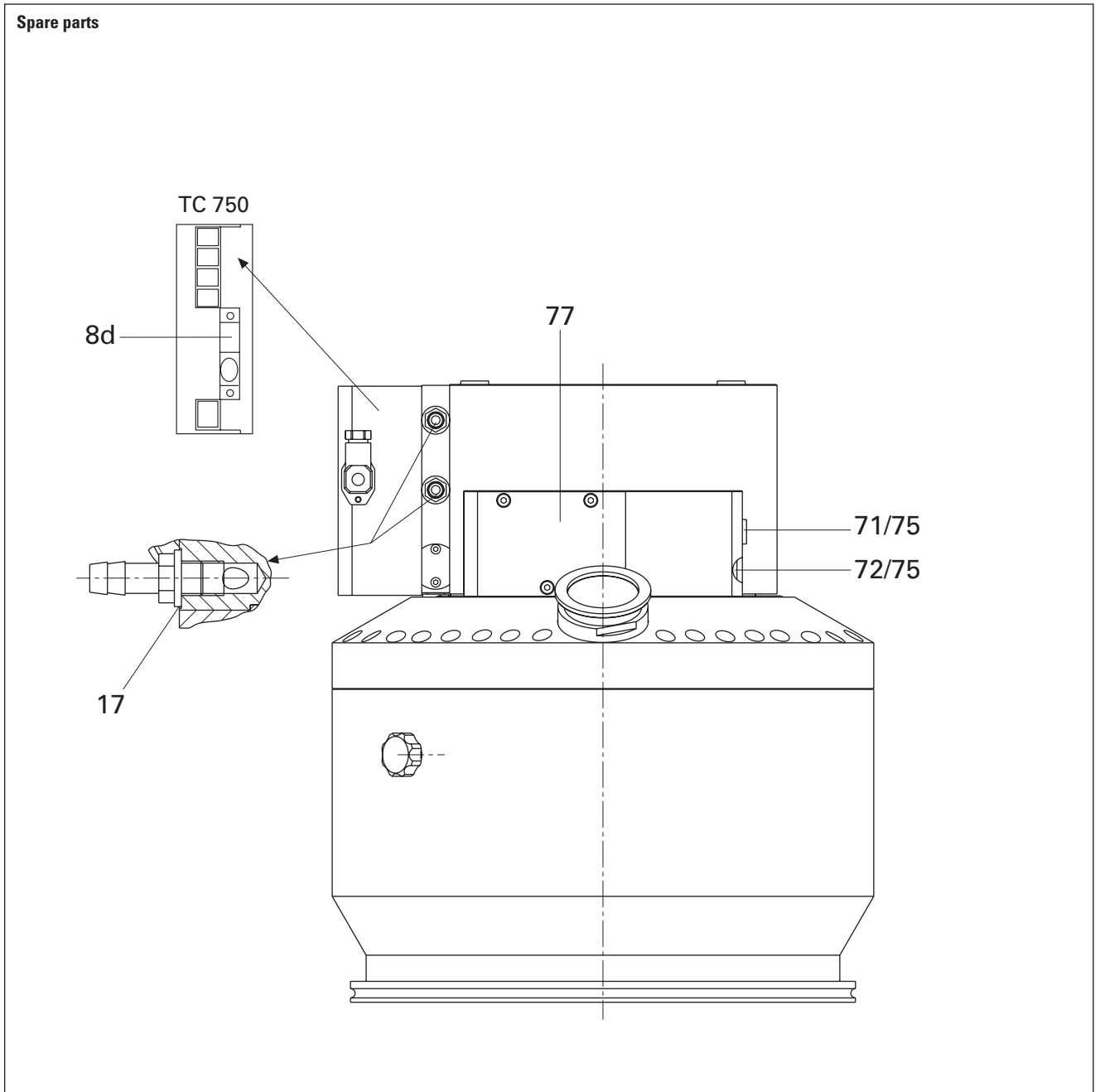



## Declaration of Contamination of Vacuum Equipment and Components

The repair and/or service of vacuum components will only be carried out if a correctly completed declaration has been submitted. Non-completion will result in delay.

The manufacturer could refuse to accept any equipment without a declaration.

**This declaration can only be completed and signed by authorised and qualified staff:**

**1. Description of component:**

- Equipment type/model: \_\_\_\_\_
- Code No.: \_\_\_\_\_
- Serial No.: \_\_\_\_\_
- Invoice No.: \_\_\_\_\_
- Delivery Date: \_\_\_\_\_

**2. Reason for return:**

\_\_\_\_\_

\_\_\_\_\_

\_\_\_\_\_

\_\_\_\_\_

**3. Equipment condition**

- Has the equipment been used?  
yes  no
- What type of pump oil was used?  
\_\_\_\_\_
- Is the equipment free from potentially harmful substances?  
yes  (go to section 5)  
no  (go to section 4)

**4. Process related contamination of equipment**

- toxic yes  no
- corrosive yes  no
- microbiological hazard\*) yes  no
- explosive\*) yes  no
- radioactive\*) yes  no
- other harmful substances yes  no

\*) We will not accept delivery of any equipment that has been radioactively or microbiologically contaminated without written evidence of decontamination!

Please list all substances, gases and by-products which may have come into contact with the equipment:

Tradename Product name Manufacturer	Chemical name (or Symbol)	Danger class	Precautions associated with substance	Action if spillage or human contact
1.				
2.				
3.				
4.				
5.				

### 5. Legally Binding Declaration

I hereby declare that the information supplied on this form is complete and accurate. The despatch of equipment will be in accordance with the appropriate regulations covering Packaging, Transportation and Labelling of Dangerous Substances.

Name of Organisation: \_\_\_\_\_

Address: \_\_\_\_\_ Post code: \_\_\_\_\_

Tel.: \_\_\_\_\_

Fax: \_\_\_\_\_ Telex: \_\_\_\_\_

Name: \_\_\_\_\_

Job title: \_\_\_\_\_

Date: \_\_\_\_\_ Company stamp: \_\_\_\_\_

Legally binding signature: \_\_\_\_\_



# Manufacturer's Declaration

pursuant to the following EU directives:

- **Machinery 98/37/EEC (Annex II B)**
- **Electromagnetic Compatibility 89/336/EEC**
- **Low Voltage 2006/95/EEC**

We hereby certify that the product specified below is intended for installation in a machine which is forbidden to be put into operation until such time as it has been determined that the end product is in accordance with the provision of EU Directive 98/37/EEC.

The product specified below is in correspondence to the EU directives Machinery **98/37/EEC**, Electromagnetic Compatibility **89/336/EEC** and Low Voltage **2006/95/EEC**.

**TPH 2101 UP**  
**TPH 2101 UPC**

Guidelines, harmonised standards, national standards in languages and specifications which have been applied:

EN 294

EN 1012-2

EN 12100-1

EN 12100-2

EN 61010

Signatures / Unterschriften:

Pfeiffer-Vacuum GmbH  
Berliner Strasse 43  
35614 Asslar  
Germany

(M. Bender)  
Managing Director  
Geschäftsführer

(Dr. M. Wiemer)  
Managing Director  
Geschäftsführer

Konf/Herst/2007

**Vacuum is nothing, but everything to us!**



**Turbopumps**



**Rotary vane pumps**



**Roots pumps**



**Dry compressing pumps**



**Leak detectors**



**Valves**



**Components and feedthroughs**



**Vacuum measurement**



**Gas analysis**



**System engineering**



**Service**

**PFEIFFER**  **VACUUM**

Pfeiffer Vacuum Technology AG · Headquarters/Germany

Tel. +49-(0) 64 41-8 02-0 · Fax +49-(0) 64 41-8 02-2 02 · [info@pfeiffer-vacuum.de](mailto:info@pfeiffer-vacuum.de) · [www.pfeiffer-vacuum.net](http://www.pfeiffer-vacuum.net)