

## ***Turbomolecular Pumps For Up-side Down Installation***



***TPH 2101 U P  
TPH 2101 U P C***

|   | Page      |   | Page      |
|---|-----------|---|-----------|
| <b>1. Safety Instructions .....</b>                   | <b>3</b>  | 4.8. Operations With The DCU 001 / DCU 600 .....  | 16        |
| 1.1. For Your Orientation.....                        | 3         | 4.9. Operations With The Remote Control Unit..... | 16        |
| 1.2. Pictogram Definitions.....                       | 3         | Venting Release (Optional).....                   | 17        |
| <b>2. Understanding The Pumps</b>                     |           | Motor, Turbopump .....                            | 17        |
| <b>TPH 2101 U P and TPH 2101 U P C.....</b>           | <b>4</b>  | Pumping Station .....                             | 17        |
| 2.1. Main Features.....                               | 4         | Heating/Reset .....                               | 17        |
| Proper Use .....                                      | 4         | Standby.....                                      | 17        |
| Improper Use .....                                    | 5         | Rotation Speed Setting Operations                 |           |
| 2.2. Differences Between The Pump Types.....          | 5         | Via Input PWM .....                               | 17        |
| 2.3. Scope Of Delivery .....                          | 5         | Switching Outputs.....                            | 17        |
| <b>3. Installation.....</b>                           | <b>6</b>  | <b>5. Monitoring Operations .....</b>             | <b>18</b> |
| 3.1. Preparations For Installation.....               | 6         | 5.1. Operations Display Via LED.....              | 18        |
| 3.2. Installing The Pump, Connecting The              |           | 5.2. Turbopump Temperature Monitoring .....       | 18        |
| High Vacuum Side.....                                 | 6         | <b>6. What To Do In Case</b>                      |           |
| 3.3. Connecting The Fore-Vacuum Side .....            | 7         | <b>Of Breakdowns? .....</b>                       | <b>19</b> |
| 3.4. Connecting The Cooling Unit.....                 | 8         | <b>7. Service.....</b>                            | <b>20</b> |
| 3.5. Connecting The Electronic Drive Unit TC 750..... | 8         | <b>8. Maintenance.....</b>                        | <b>21</b> |
| 3.6. Connecting The Venting Valve.....                | 10        | 8.1. Replacing The Lubricant.....                 | 21        |
| 3.7. Installing The Power Unit .....                  | 10        | 8.2. Cleaning The Lubricating Pump.....           | 22        |
| 3.8. Connecting The Sealing Gas Valve .....           | 10        | <b>9. Technical Data.....</b>                     | <b>24</b> |
| 3.9. Connecting The Remote Control Unit .....         | 11        | 9.1. Dimensions Diagram .....                     | 25        |
| 3.10. Connecting The Serial Interface RS 485 .....    | 12        | <b>10. Spare Parts.....</b>                       | <b>26</b> |
| Connection .....                                      | 12        | <b>11. Accessories .....</b>                      | <b>28</b> |
| Connecting The RS 485 .....                           | 12        | 11.1. Lubricant.....                              | 28        |
| 3.11. Connections Diagram.....                        | 13        | <b>Declaration of Contamination.....</b>          | <b>29</b> |
| <b>4. Operations.....</b>                             | <b>14</b> | <b>Manufacturer's Declaration.....(last page)</b> |           |
| 4.1. Filling In The Lubricant.....                    | 14        |   |           |
| 4.2. Before Switching ON.....                         | 14        |   |           |
| 4.3. Switching ON.....                                | 15        |   |           |
| 4.4. Gas Type Dependent Operations .....              | 15        |   |           |
| 4.5. Circulatory Lubrication.....                     | 16        |   |           |
| 4.6. Switching OFF And Venting .....                  | 16        |   |           |
| 4.7. Shutting Down For Longer Periods .....           | 16        |   |           |

**Please note:** Current operating instructions are available via [www.pfeiffer-vacuum.de](http://www.pfeiffer-vacuum.de) under "Infoservice".

# 1. Safety Instructions

- ☞ Read and follow all instructions in this manual.
- ☞ Inform yourself regarding:
  - Hazards which can be caused by the pump;
  - Hazards which can be caused by your system.
  - Hazards which can be caused by the media being pumped.
- ☞ Avoid exposing any part of the body to vacuum.
- ☞ Observe the safety and accident prevention regulations.
- ☞ Regularly check that all accident prevention measures are being complied with.
- ☞ Do not operate the turbopump with open high vacuum flange.
- ☞ Do not carry out any unauthorised conversions or alterations to the turbopump with TC 750.
- ☞ When returning the turbopump observe the shipping instructions.
- ☞ Use at least 12 bracket screws to connect the high vacuum flange (ISO-flange).
- ☞ The turbopump must be anchored in accordance with the installation instructions.
- ☞ Do not disconnect the plug between the TC 750 and accessory components during operations.
- ☞ Disconnect the voltage supply to the TC 750 before opening the turbopump.
- ☞ When working on the turbopump, the high vacuum flange should only be opened once the rotor is at rest.
- ☞ When using sealing gas, the pressure in the hose connection should be limited to 2 bar via the overpressure valve.
- ☞ If a heater is in use temperatures of up to 120 °C can arise in the area of the high vacuum flange. Take care to avoid burns!
- ☞ During operations temperatures of up to 65 °C can arise in the lower part of the turbopump. Take care to avoid burns!
- ☞ Keep leads and cables well away from hot surfaces (> 70 °C).
- ☞ Operate the turbopump with TC 750 only in conjunction with the relevant power unit (accessory).
- ☞ The unit has been accredited protection class IP 30. When the unit is operated in environments which require other protection classes, the necessary measures must be taken. Protection class IP 54 is afforded by retro-fitting a cover plate (accessory) to the TC 750.
- ☞ The mains connection must be subject to a safe connection to the PE (protection class 1).
- ☞ If the turbopump and the TC 750 are operated separately (only permissible with the agreement of the manufacturer) the turbopump must be connected to the PE.
- ☞ The turbopump and the TC 750 must only be disconnected from each other when the turbopump is completely at rest and the TCP 750 has been disconnected from the power supply.
- ☞ The cause of any operating voltage leakage to earth (red LED flashes) must be eliminated to avoid the danger of an electric shock.

Modifications reserved.

## 1.1. For Your Orientation

### Instruction in the text

➔ Working instruction: here, you have to do something.

### Symbols used

The following symbols are used throughout in illustrations:

- Ⓜ High vacuum flange
- Ⓥ Fore-vacuum flange
- Ⓧ Venting connection
- Ⓝ Cooling water connection
- Ⓛ Electric connection
- Ⓞ Sealing gas connection

### Abbreviations used

DCU = Operating and display control unit

TC = Electronic drive unit, turbopump

TPS = Power unit

TMP = Turbomolecular pump

### Position numbers

The same pump and accessory parts have the same position numbers in all illustrations.

## 1.2. Pictogram Definitions



Danger of burns from touching hot parts.



Danger of personal injury.



Danger of damage to the pump or to the system.



Danger of injury from rotating parts.



Attention to particularly important information on the product, handling the product or to a particular part of the documentation.

## 2. Understanding The Pumps

### TPH 2101 U P And TPH 2101 U P C

#### 2.1. Main Features

Turbopumps TPH 2101 U P/TPH 2101 U P C with the TC 750 form a complete unit. Voltage is supplied by power unit (see "Accessories").



On delivery, the pumps have been set up for operations in remote mode. Remote plug 8d (please refer to Section 10.) should therefore be disconnected from the TC 750 if operations with the DCU are required.



#### Cooling

Standard: Water cooling

Integrated protective measures against excess temperatures:  
The Electronic Drive Unit TC 750 reduces the rotor rotation speed.

#### Bearings

High vacuum side: Wear free permanent magnetic bearing.

Fore-vacuum side: Oil circulatory lubricated ball bearing with ceramic balls.



The turbopumps must **not** be transported when filled with lubricant.

When being fitted into or dismantled from a system, turbopumps may **only be positioned as shown in Section 3.2**. Other positions can cause the pumps to be contaminated with lubricant.

#### Proper Use

- The Turbomolecular Pumps TPH 2101 U P and TPH 2101 U P C may only be used for the purpose of generating vacuum.
- The Turbomolecular Pumps TPH 2101 U P C are designed to pump corrosive gases and vapours. Where corrosive gas processes are involved, gas bonding and particles which can damage the surfaces of the pump can be produced. The motor and bearing compartments have to be protected with sealing gas.
- The turbopumps may only be used to pump those media against which they are chemically resistant. For other media the operator is required to qualify the pumps for the processes involved.
- If the process produces dust, the maintenance intervals must be specified accordingly and sealing gas must be used.
- If the pump is to be operated with more than 50% of the permissible gas load then sealing gas should be used to ensure rotor cooling.
- The turbopump must be connected to a backing pump in accordance with Section 3.3.
- Only PFEIFFER power units may be used to operate the TC 750. The use of other power units requires the prior agreement of the manufacturer and equalisation with the valid specification.
- The pumps may only be operated providing the ambient conditions in compliance with Protection Type IP 30 are observed.

## Improper Use

The following is regarded, inter alia, as improper:

- The pumping of explosive gases.
- Operating the pumps in areas where there is a danger of explosion.
- The pumping of gases and vapours which attack the materials of the pumps.
- The pumping of corrosive gases without sealing gas.
- The pumping of condensating vapours.
- Operations involving impermissibly high levels of gas loads.
- Operations with impermissibly high fore-vacuum pressure.
- Operations with improper gas modes.
- Operations involving too high levels of heat radiation power (see Section 9. "Technical Data").
- Operating the pump in environments which require a protection class superior to IP 30.
- The use of other power units or accessories which are not named in this manual or which have not been agreed by the manufacturer.
- The connection to power units with earthing of a direct voltage pole.

Improper use will cause all claims for liability and guarantees to be forfeited.

## 2.2. Differences Between The Pump Types

**TPH 2101 U P**            **Standard version**  
**TPH 2101 U P C**        **Corrosive gas version**

| Feature                   | TPH 2101 U P             | TPU 2101 U P C           |
|---------------------------|--------------------------|--------------------------|
| High vacuum flange        | ISO-K                    | ISO-K                    |
| High vacuum seal          | Viton                    | Viton                    |
| Attainable final pressure | $< 1 \cdot 10^{-8}$ mbar | $< 1 \cdot 10^{-8}$ mbar |

### Abbreviations on the rating plate of the pump

#### TPH 2101

- Suffix "C": Surface protection for passive protection of the pump
- Suffix "P": Purge gas connection for the prevention of the ingress of aggressive gases into the motor and bearing area
- Suffix "U": Upside down fitting of the turbomolecular pump

## 2.3. Scope Of Delivery

The turbopump scope of delivery includes:

- Lubricant F3 (40 cm<sup>3</sup>) with filling syringe.

## 3. Installation

### 3.1. Preparations For Installation



Do not carry out any unauthorised conversions or alterations to the turbopump.

- Pumps must be filled with lubricant before being operated (see Section 4.1.).
- The turbopumps must **not** be transported when filled with lubricant.
- If the turbopump is to be operated with the DCU, the remote plug 8d on the TC 750 should be disconnected (please see Section 10.) and then proceed in accordance with Operating Instructions "Pumping Operations With The DCU", PM 800 547 BN.
- The maximum permissible rotor temperature of the pump is 120 °C. If the vacuum chamber or parts in the vacuum chamber are heated, the values stated in the technical data relating to the level of heat which may be radiated into the pump must not be exceeded. If necessary, suitable shielding must be fitted in the vacuum chamber before the turbopump (constructional suggestions available on request).
- Only remove the blank flange from the high and fore-vacuum side immediately before connection.
- Where magnetic fields of > 7 mT are involved suitable shielding must be provided (available on request).
- If the pump is baked out, the heating sleeve and the body of the pump must be insulated to prevent burns from accidental contact.
- In the event of a sudden standstill of the rotor, torques of up to 6000 Nm can arise and these must be taken up by the turbopump and frame. Pumps must be anchored as follows:
  - ISO flange with 12 bracket screws,
  - or
  - underside of the pump with 4 screws M12, screws quality 10.9. at least.

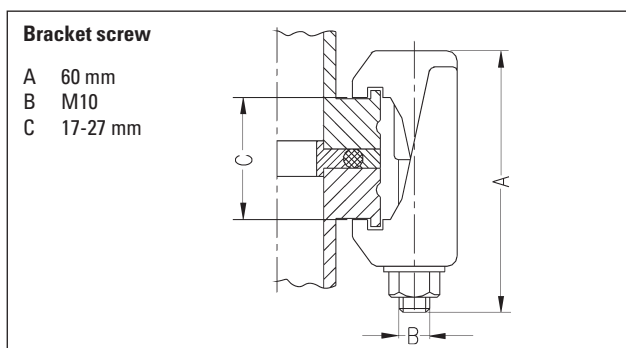

The person responsible for commissioning must ensure that the installation is carried out in accordance with the legal regulations and the pertinent industrial standards.

### 3.2. Installing The Pump, Connecting The High Vacuum Side



The utmost cleanliness must be observed when fitting all high vacuum parts. Unclean components prolong the pumping time.

#### Use a splinter shield

The use of a splinter shield (accessory) in the high vacuum flange protects the turbopump against foreign bodies coming from the vacuum chamber but does reduce the volume flow rate of the pump by approximately 15%.

The high vacuum side can be flanged onto the vacuum chamber either directly or via a bellows or a PFEIFFER vibration compensator (see "Accessories").

#### Connecting via bellows

If the high vacuum side is to be flanged via a bellows, the turbopump must be secured for example via the holes on the underside of the turbopump (please see dimensions diagram). The fastening must be able to withstand the torque referred to in Section 3.1.

#### Connecting via a PFEIFFER vibration compensator



The maximum permissible temperature at the vibration compensator is 100 °C.

Where a vibration compensator is in use, a freely suspended turbopump can be flanged onto the vacuum chamber. Additional protective casing must be provided to take up the energy of the rotor in the event of a malfunction (please discuss this question with the manufacturer).

### Directly Flanging The Pump

The turbopump can be flanged onto the vacuum chamber vertically (up-side down) up to an angle of 90° maximum.



The fore-vacuum flange must always point downwards.

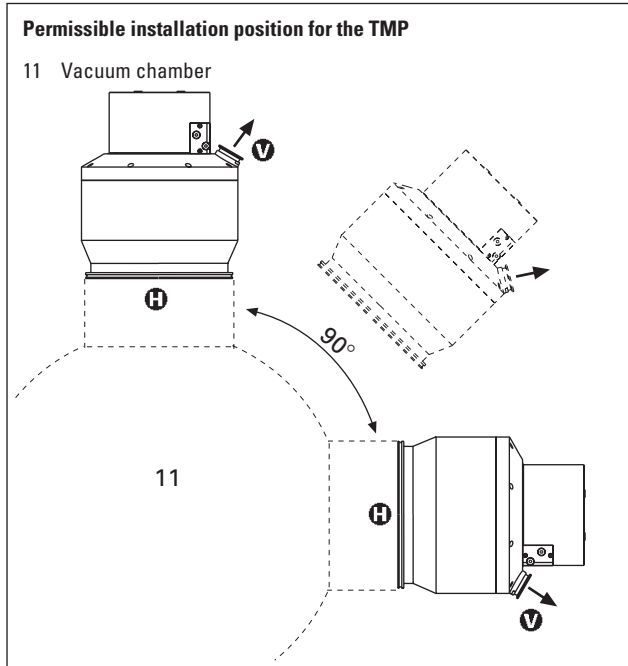

The maximum loading capacity of the high vacuum flange is 2000 N. Asymmetric loading on the high vacuum flange must be avoided.



When operating, a turbopump which has been installed in the upside down position must not be tilted by more than 3° in the opposite direction to the fore-vacuum flange otherwise lubricant is not secured.

If the pump is being installed horizontally:  
The fore-vacuum flange of the turbopump must be aligned downwards (maximum deviation  $\pm 15^\circ$ ), otherwise the turbopump could become dirty and the lubricating pump not properly function.

### Horizontal installation position of the turbopump

11 Vacuum chamber

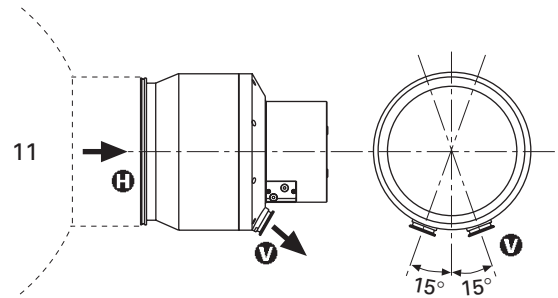

No forces from the piping system must be allowed to act on the pump where turbopumps are anchored. Suspend or support all pipes to the turbopump.

### 3.3. Connecting The Fore-Vacuum Side

Backing pump: Fore-vacuum pressure please see "Technical Data"

Recommendation: Dry Backing Pumps or Rotary Vane Vacuum Pumps from the PFEIFFER range.

#### Connecting the backing pump

All connections of the fore-vacuum line: With the usual small flange components or screwed hoses.



Be sure to conduct away the exhaust gases from the backing pump. Do not reduce the free cross section of the fore-vacuum flange with following components.



The exhausted process gases and vapours can represent a health hazard and can also be environmentally damaging. Comply with all the gas manufacturer's safety instructions.

- ➔ With rigid pipe connections: Fit a bellows in the connecting line to reduce vibration.
- ➔ The electrical connection of the backing pump is made via a relay box (Accessory) whose control line is connected to "FV PUMP" on the TC 750.

Please refer to Operating Instructions PT 800 030 BN for details on the relay box, backing pump and its installation.

### 3.4. Connecting The Cooling Unit

The Turbopumps TPH 2101 U P/TPH 2101 U P C have been designed to be water cooled as standard.  
(cooling water connection please refer to Section 9.1. Dimensions Diagram)

#### Water Cooling

The cooling water can be drawn either

- from the cooling water mains, or
- from Recycled Water Cooling Unit TZK in closed circuit.

#### Cooling from the cooling water mains

To prevent deposits collecting in the pump the cooling water must be filtered.

#### Minimum cooling water requirements:

Mechanically clean, optically clear, no turbidity, no sediment, chemically neutral, temperature >dew point.

|  |                  |
|--|------------------|
| Oxygen content:                        | max. 4 mg/kg     |
| Chloride content:                      | max. 100 mg/kg   |
| Carbonate hardness:                    | max. 10 ° dH     |
| Consumption of potassium permanganate: | max. 10 mg/kg    |
| Carbon dioxide:                        | Undetectable     |
| Ammonia:                               | Undetectable     |
| pH-value:                              | 7 – 9            |
| Max. fore-line overpressure:           | max. 6 bar       |
| Minimum flow rate at gas load max.:    | 100 l/h at 15 °C |

#### Connection to the cooling water mains

- ➔ Fit the dirt trap (Accessory) in the supply line.
- ➔ Connect the supply line with hose clips onto one of the two cooling water connections.
- ➔ Connect the return line to the other cooling water connection of the turbopump.
- ➔ Tighten cooling water connection to a torque of 10 Nm.
- ➔ Tighten all hose clips and check for firm seating of the hoses.

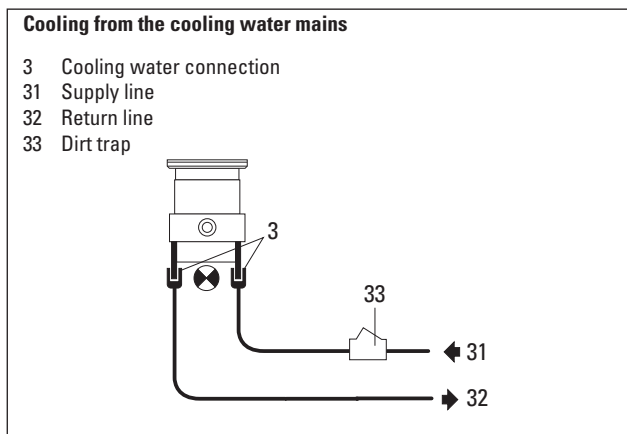

### Cooling with the Recycled Water Cooling Unit TZK (Accessory)

#### Connection to the TZK

Dirt traps are impermissible in the lines.

All other steps as for connecting to the cooling water mains.

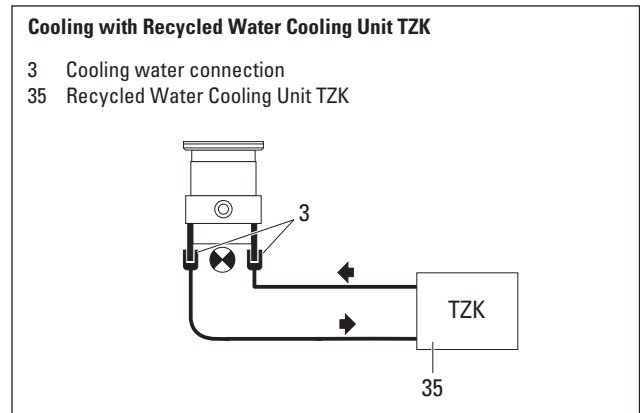

### 3.5. Connecting The Electronic Drive Unit TC 750



The turbopump and the Electronic Drive Unit TC 750 are connected and together form a single unit.  
The connecting cable 8a has to be ordered separately in the required length (see "Accessories").

- ➔ Unscrew screw with tooth lock 8c from the TC 750 (above the connection X4).
- ➔ Plug the plug X4 on connecting cable 8a into the connection X4 on the TC 750 and screw in screw 8b.
- ➔ Secure plug X4 on the TC 600 with a screw and tooth lock 8c.
- ➔ Connect plug X2 on connecting cable 8a with power unit TPS 600/DCU 600 ("Accessories") on connection X2.
- ➔ Using screws and toothlock 8c (two pieces, included with the cable consignment) secure plug X2 to power unit 105.



Once operations voltage has been supplied, the TC 750 performs a self test on the supply voltage.  
The supply voltage for the turbopumps is 140 VDC  $\pm$  5% in accordance with EN 60 742.

If the turbopump is to be operated with the Display and Operating Unit DCU 001/DCU 600, the remote plug 8d on the TC 750 (please see Section 10.) should be disconnected and then proceed in accordance with Operating Instructions PM 800 477 BN.

#### Connecting the TC 750 with Power Unit TPS 600/DCU 600

- X1 Mains connection
- X2 Connection, Power Unit TPS 600
- X4 Connection TC 750
- S1 ON/OFF switch
- 8 Electronic Drive Unit TC 750
- 8a Connecting cable, TC 750 – TPS/DCU
- 8b Screw
- 8c Screw with tooth lock (3 pieces)
- 105 Power Unit TPS 600

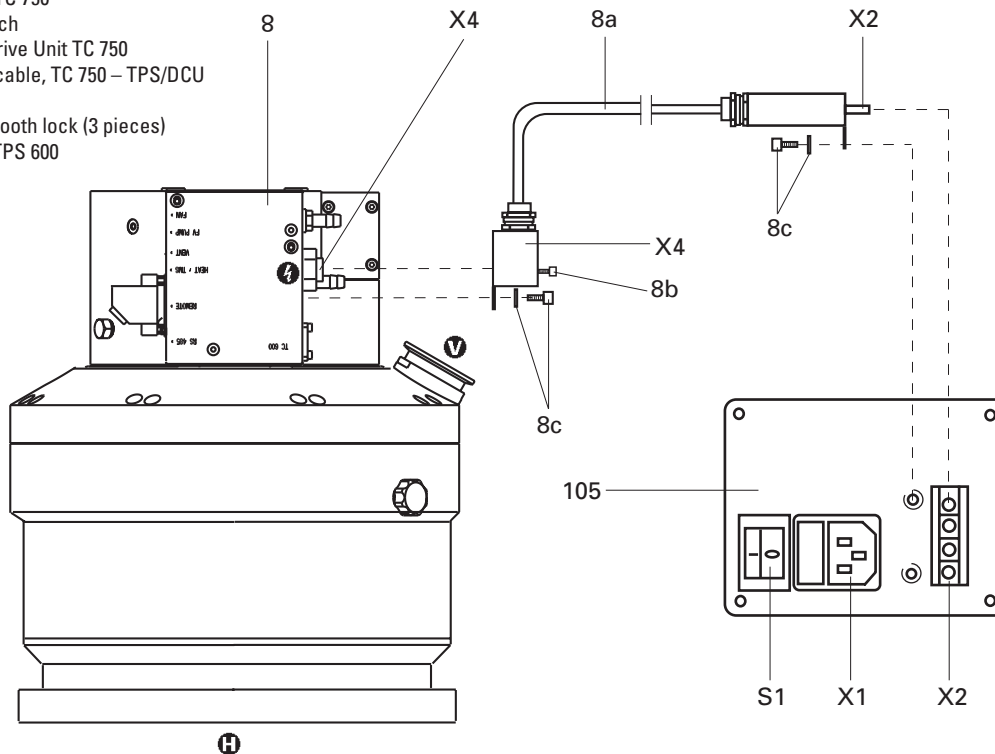

### 3.6. Connecting The Venting Valve

The venting valve (Accessory) provides automatic venting in the event of a power failure and switching off.

#### Fitting the venting valve

- ➔ Unscrew the venting screw 4 (see Section 2.1.) from the venting connection of the turbopump.
- ➔ Screw in venting valve 42 with seal (USIT ring) on hexagonal SW 14.

#### Electrical connection

- ➔ Plug control lead 42a into the connection "VENT" of the TC 750 (8) on the turbopump.

Release for venting is executed via remote plug pin 2 (pre-set on delivery, please see Section 4.9.).

The venting mode of the venting valve is selected via the DCU or Serial Interface RS 485.



The maximum pressure at the venting valve is 1.5 bar absolute.

Please refer to Operating Instructions PM 800 507 BN for details on Venting Valve TVF 005.

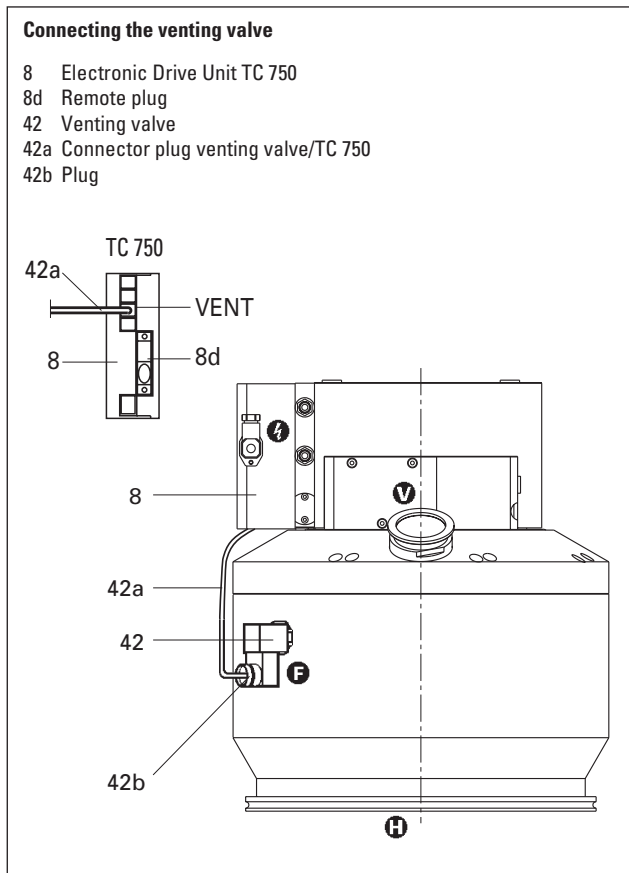

### 3.7. Installing The Power Unit



Voltage may only be supplied with the PFEIFFER power units (please see "Accessories").

The use of other power units requires the prior agreement of the manufacturer and equalization with the valid specification (power unit specifications available on request).



Operations with TPS 600/DCU 600 are only possible in the connection voltage range 185-265 V AC.

For operations in the connected voltage range 90 - 132 VAC please refer to Operating Instructions "Pumping Operations With DCU", PM 800 547 BN.

Please refer to Operating Instructions PM 800 521 BN for details on power unit TPS 600.

### 3.8. Connecting The Sealing Gas Valve

For protection purposes the turbopump should be operated with sealing gas, particularly where corrosive and dusty processes are involved.

Even in non-corrosive processes, from 50% of the maximum gas load sealing gas should be used to ensure rotor cooling.

Connection is made via the sealing gas valve (please see "Accessories").

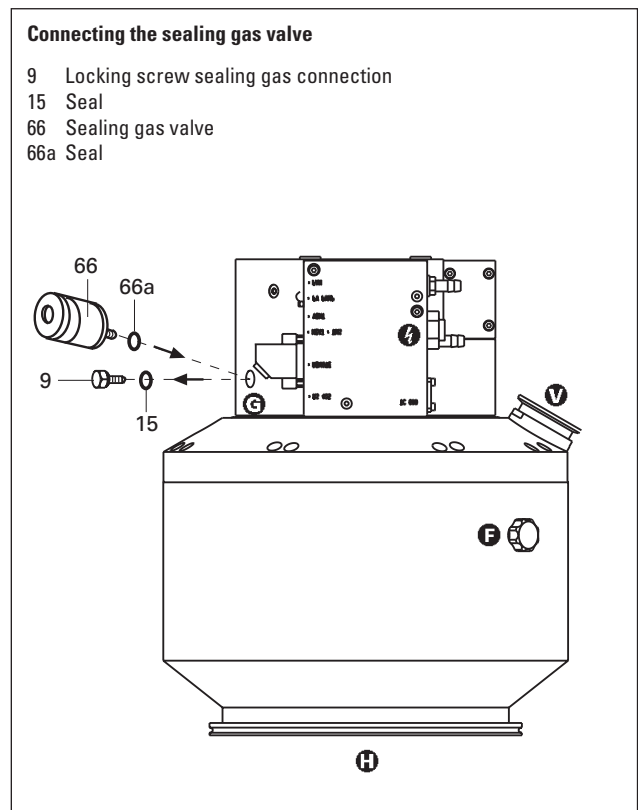

Please refer to Operating Instructions PM 800 229 BN for details on installing the sealing gas valve and adjusting the sealing gas flow.

## Connecting The Remote Control Unit

Remote control options for various functions are provided with the connection "REMOTE" on the TC 750 via the 15-pole D-Sub-Connector. Shielded cable must be used. Shielding is on the plug side of the TC 600 connected to the TC casing.

The inputs 2-6 are activated by connecting them to the + 24 V on pin 1 (active high) (please see "Connection Diagram").

**Pin occupancy and remote plug functions**  
(please see following table).

**CAUTION** When connecting supply voltage, the turbopump is started.  
**On delivery:**  
**Pin 1, Pin 2, Pin 3 and Pin 4 are bridged in the mating plug.**

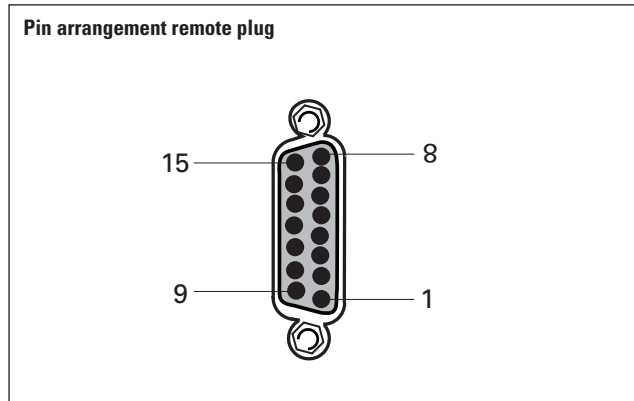

| Pin occupancy and remote plug functions |  |   |
|---|--|---|
| Pin nr.                                 | Input open (low)   | Input closed (high) on + 24V (pin 1)  |
| 1                                       | +24 V  |   |
| 2                                       | venting blocked (see Section 3.6.)                             | venting released (see Section 3.6.)   |
| 3                                       | motor, turbopump off   | motor, turbopump on:<br>the turbopump is driven, current flows through the motor coils  |
| 4                                       | pumping station off  | pumping station on:<br>the turbopump is driven, backing pump is started via the relay box   |
| 5                                       | heating off  | heating on:<br>the heating is switched on once the rotation speed switchpoint is attained and off when the rotation speed switchpoint is unattained   |
| 5                                       |  | reset:<br>by supplying a pulse (T < 2s) with an amplitude of 24V a malfunction acknowledgement can be processed                                       |
| 6                                       | standby off  | standby on:<br>pump is accelerated to 66% of its nominal rotation speed   |
| 7                                       | rotation speed setting mode off                                | the rotation speed can be changed by feeding a PWM signal to this pin or via Serial Interface RS 485 (see Section 4.9. "Rotation Speed Setting Mode") |
| 8                                       | <b>Output (low)</b><br>rotation speed switchpoint not attained | <b>Output (high)</b><br>rotation speed switchpoint attained; output can be loaded with 24 V/50 mA   |
| 9                                       | <b>Output (low)</b><br>Collective malfunction message          | <b>Output (high)</b><br>malfunction-free operations;<br>output can be loaded with 24 V/50 mA  |
| 10                                      | Mass (ground)  | _____   |
| 11                                      | Contact<br>Output 1: Switchpoint attained                      | contact <sup>1)</sup> between pin 11 and pin 12 closed<br>if the turbopump is above the switchpoint   |
| 12                                      | Contact<br>Output 1: Switchpoint attained                      |   |
| 13                                      | Contact<br>Output 2: Collective malfunction message            | contact <sup>1)</sup> between pin 13 and pin 14 open in the event of a collective <sup>1)</sup> malfunction   |
| 14                                      | Contact<br>Output 2: Collective malfunction message            |   |
| 15                                      | Analog output  | rotation speed proportional output voltage 0 - 10 VDC =<br>0 - 100 % * fend/load R ≥ 10 kΩ  |

1) The following technical data is applicable for the contacts:  $U_{max} = 50 \text{ VDC}$   
 $I_{max} = 1 \text{ A}$

### 3.10. Connecting The Serial Interface RS 485

An external operating component (DCU 001 or DCU 600) or an external computer can be connected via the connection "RS 485" on the TC 750 with the use of a shielded 8 pole modular connecting cable contained with the delivery.

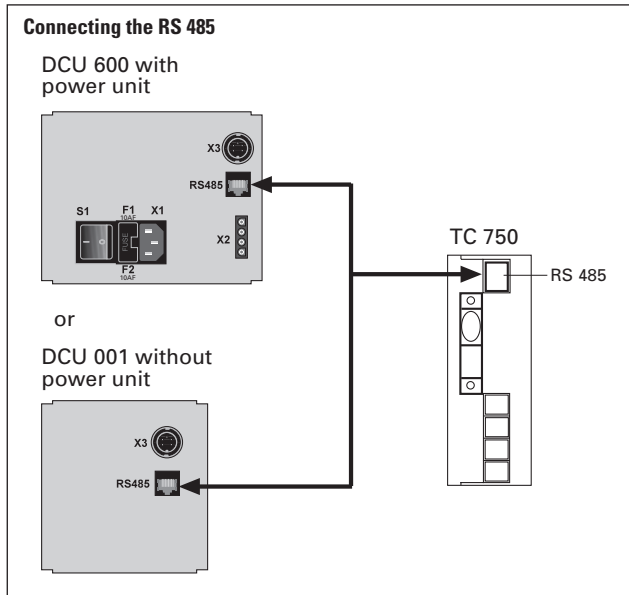

The serial interface is galvanically and safely separated from the maximum supply voltage from the TC 750.

#### Connection

| Description            | Value          |
|------------------------|----------------|
| Serial Interface Type: | RS 485         |
| Baud rate:             | 9600 baud      |
| Data file word length: | 8 bit          |
| Parity:                | no (no parity) |
| Start bits:            | 1              |
| Stop bits:             | 1..2           |

The electrical connections are internally optically decoupled.

| PIN | Arrangement                             | RS 485   |
|-----|---|--|
| 1   | not connected                           | <br>1 ... 8<br>(View from the plug side of the TC 750) |
| 2   | +24V output (≤ 210 mA loading capacity) |  |
| 3   | not connected                           |  |
| 4   | not connected                           |  |
| 5   | RS 485: D+ (DO / RI)                    |  |
| 6   | Gnd — —                                 |  |
| 7   | RS 485: D- (DO / RI)                    |  |
| 8   | not connected                           |  |



It is possible to connect an RS 232 (e.g. PC) via a level converter (please see "Accessories").

### Connecting The RS 485

#### Connecting to a fixed bus system:

- ➔ Connect all units with D+ (pin 5/RS 485) and D- (pin7/RS 485) to the bus.
- ➔ The bus must be completed at both ends.

The connections should be made in accordance with the specification of the Serial Interface RS 485.

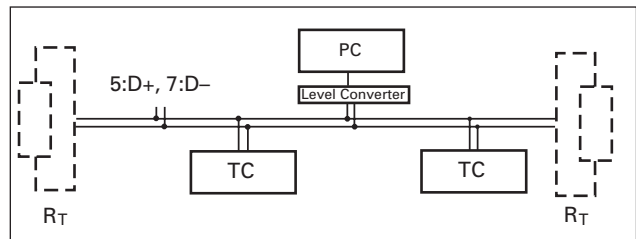

All units connected to the bus must have differing serial interface addresses (parameter 797). The group address of the TC 600 is 960.



Only safety low voltages (SELV) may be connected to Serial Interface RS 485.

All switched on remote functions have priority over the serial interface functions.



Please refer to the separate Operating Instructions PM 800 488 BN for more detailed information on operations via Serial Interface RS 485 and its electronic data.

Profibus DP Gateway TIC 250 is available (accessory) for connecting an Electronic Drive Unit TC 750 to a Profibus DP. Please refer to the respective Operating Instructions PM 800 599 BN for detailed information on the operation of the TIC 250.

### 3.11. Connections Diagram

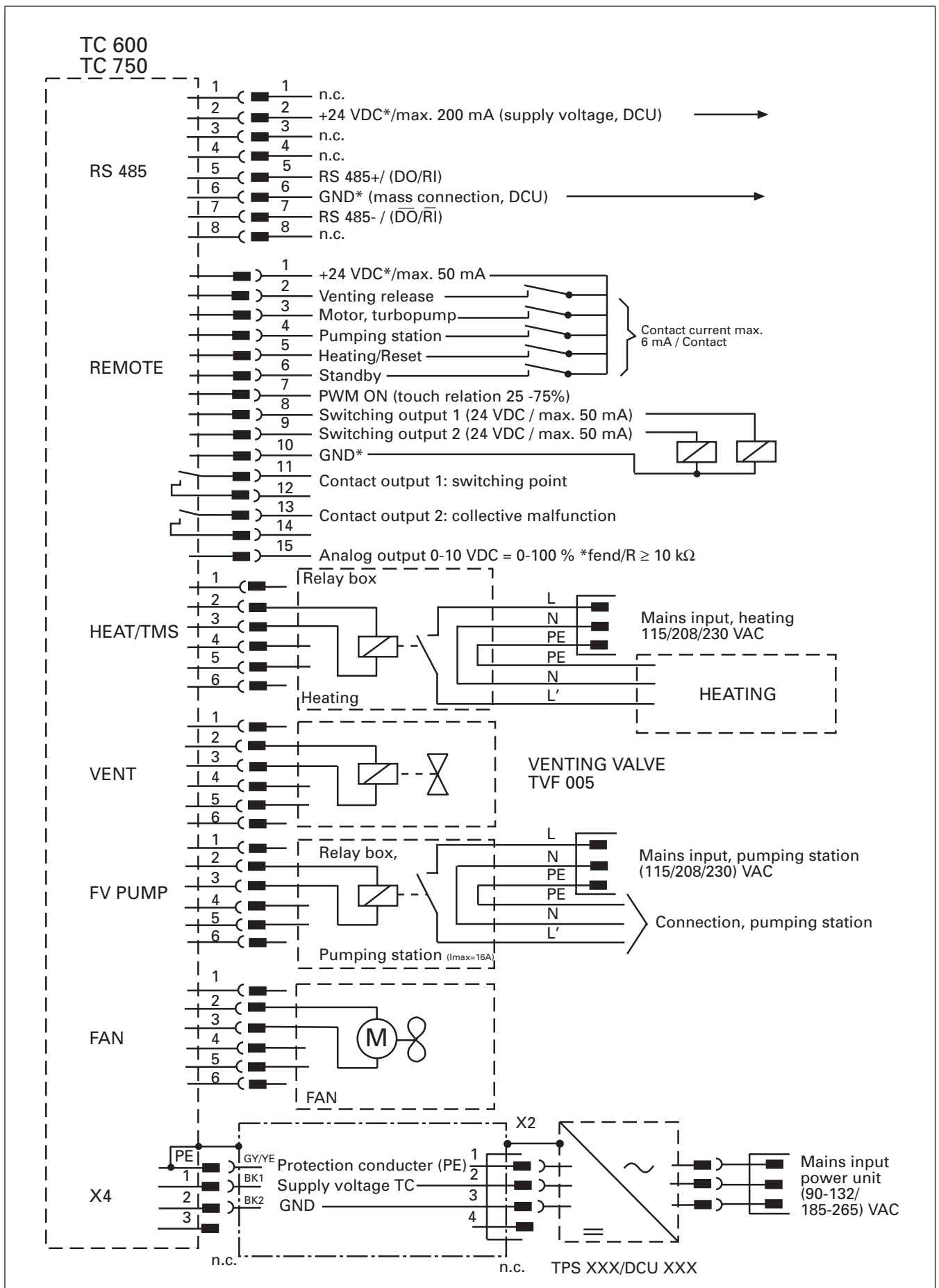

## 4. Operations

### 4.1. Filling In The Lubricant



Pumps must be filled with lubricant before being operated.

If possible fill in the lubricant in the fitting position of the pump.

Pumps are designed to operate with Lubricant "F3" contained with the delivery 40 cm<sup>3</sup> (see rating plate).



If "F3" is heated above 300 °C, toxic vapours which can harm the airways are given off. Do not allow "F3" to come into contact with tobacco products (danger of poisoning when ignited). The precautions necessary in the handling of chemicals must be observed.

#### Filling in the lubricant

- ➔ Unscrew lubricant filler screw 71 and, using the syringe provided, inject approximately 40 cm<sup>3</sup> of lubricant.



Where the set-up position is vertical or horizontal the maximum lubricant level in the sight glass is the lower edge of lubricant filler screw 71.

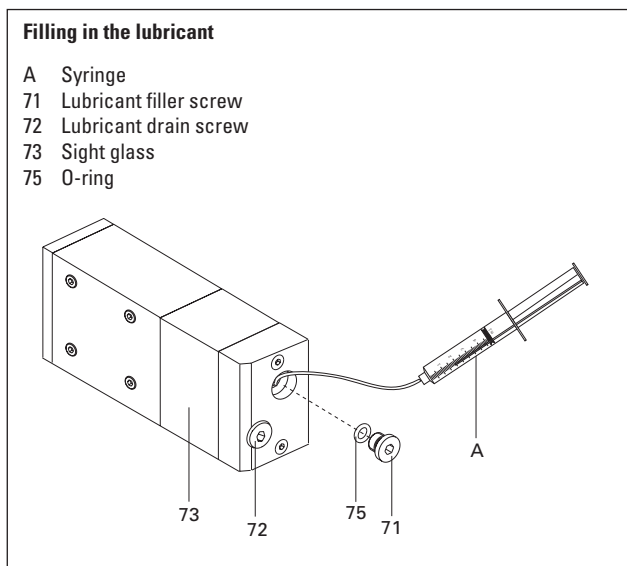

- ➔ Screw back in lubricant filler screw 71 with the O-ring 75.



It is essential to ensure that the lubricating pump is not over-filled with lubricant. Overfilling will cause the excess lubricant to be secreted from the hole for the lubricant filler screw 71.

If necessary, dismantle the lubricating pump from the pump and fill up with lubricant (please see Section 8.1).

### 4.2. Before Switching ON

Sections 4.2 to 4.6. refer only to operating the pump in its condition on delivery, without the DCU operating unit. The bridges "venting release", "motor, TMP ON" and "pumping station ON" are fitted in the remote control plug.

The pump starts automatically once voltage is supplied.

Please refer to Section 4.8. regarding the switching on with the Operating And Display Control Unit DCU.



Turbopump rotors rotate at high speed. When the high vacuum flange is open there is a danger of injury and of damage to the pump caused by objects falling into the pump. Therefore never operate the pump with open high vacuum flange!



Take care when pumping hazardous gases and observe the safety precautions of the gas manufacturer!

- ➔ With sealing gas: Open the sealing gas supply.
- ➔ Open cooling water supply and check flow.
- ➔ Plug connecting cable 8a ("Accessory") into the TC 750 and connect with Power Unit TPS 600 on X2 (please see Section 3.5.).

#### Please note:

The following pre-settings have been programmed:

- Start-up time 11 min
- Rotation speed switchpoint 80%
- Automatic venting 50%

These settings can only be altered via Serial Interface RS 485 (DCU or PC); please refer to the respective operating instructions.

### 4.3. Switching ON

- ➔ Switch on the turbopump with switch S1 on the power unit.
- Once the self test has been successfully completed on the TC 750 (duration approximately 20 seconds), both the turbopump and the backing pump (if connected) begin operating.

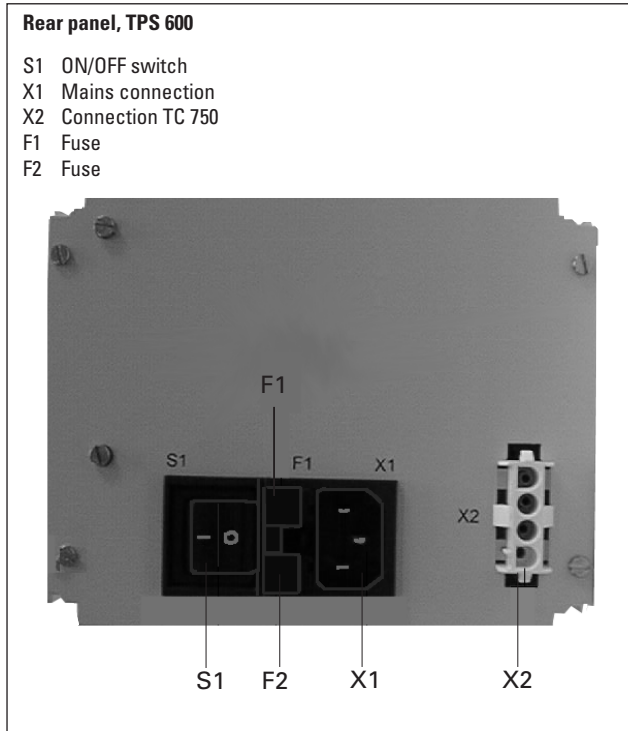

When the unit is switched on for the first time or after a lubricant change the contact to the lubricating pump can open as a result of the degassification of the lubricant. In such cases, as for other malfunctions, the electronic drive unit shuts down the turbopump.

- ➔ The turbopump must be re-started with switch S1 on the power unit.

### 4.4. Gas Type Dependent Operations



Water cooling is required if the pumps are to be operated with gas load.

Where high level gas loads and rotation speeds are involved, the resulting friction subjects the rotor to the effect of great heat. To avoid over-heating, a power rotation speed characteristic line is implemented in the TC 750; this ensures that where maximum gas loads are involved, the pump will operate at any rotation speed without the danger of damage arising.

The maximum power is dependent on the type of gas. Two characteristic lines are available for any type of gas in order to fully exploit the power potential of the pump:

- "Gas-Mode 0" for gases with molecular mass  $\geq 40$  as, for example, Argon;
- "Gas-Mode 1" for all lighter gases.

- ➔ Set the applicable gas mode on the TC 750 via the DCU (please refer to Operating Instructions "Pumping operations with the DCU" PM 800 547 BN).



Pumping gases with molecular mass  $\geq 40$  with the incorrect gas mode can cause damage to the pump.

For the vertex of the power characteristic line please refer to Section 9. Technical Data.

Maximum power is applied when the pump starts in order to limit the time required. Once the set rotation speed is attained, switching to the selected power characteristic line is automatic.

If the gas dependent maximum power is exceeded, the rotation speed is reduced until equilibrium between the permissible power and gas friction is attained. The power limitation serves to protect the pump against thermal overloading. In order to avoid rotation speed fluctuations it is recommended to set, in rotation speed setting mode, the equilibrium frequency or a somewhat lower frequency.



There can be types of pump whereby there is no differentiation between the two "gas modes" settings.

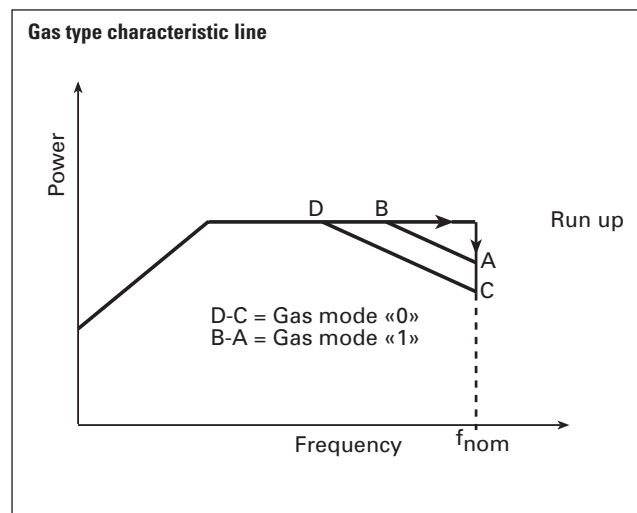

#### 4.5. Circulatory Lubrication

The ball bearing on the fore-vacuum side is supplied with lubricant via the lubricating pump.

The circulation of the lubricant is monitored via a switching contact. If there is insufficient lubricant, the electronic drive unit switches off the turbopump. Monitoring is active only from 60% of the final rotation speed.

If, at a rotation speed of > 60% of the final rotation speed (for example through the degassification of the lubricant), the contact opens for  $\geq 2$  minutes, the electronic drive unit assumes a lubricant deficiency and switches off the turbopump.



In rotation speed setting mode with set speed below 60% of the rated rotation speed the pump is first accelerated to 60% and then adjusted to the selected rotation speed.

- ➔ Check the filling level of the lubricant.
- ➔ Re-start the turbopump with switch S1 on the power unit.

#### 4.6. Switching OFF And Venting

To avoid contamination occurring when switching off, the pump should be vented before shut-down.

- ➔ Switch off both turbopump and backing pump on the power unit at the same time with switch S1. Where corrosive gas processes are involved, the sealing gas supply should be shut off after approximately 10 minutes and both turbo pump and backing pump switched off with switch S1.

##### ➔ Venting

There are three possibilities to vent turbopump:

- **Manual venting** with the use of the venting screw (status on delivery).
- **Venting with the venting valve** which is selectable via the remote control (please see Section 4.9.), or via the DCU (see Operating Instructions, "Pumping Operations With The DCU", PM 800 547 BN).
- **Venting in two stages** when the vacuum chamber should be vented as quickly as possible. First stage: venting with a pressure increase rate of 15 mbar/s for 20 seconds. Second stage: venting with an optionally large venting valve.

The valve cross-section for a venting rate of 15 mbar/s must be compatible with the size of the vacuum chamber. Where small vacuum chambers are involved, the PFEIFFER Venting Valve TVF 005 can be used for first stage venting.

- ➔ Shut off water supply.

#### 4.7. Shutting Down For Longer Periods



Vacuum pumps are sometimes used to pump aggressive or hazardous gases. There is a danger of personal injury resulting from coming into contact with process gases. Before removing a turbopump from the system, first:

- Vent the turbopump with a neutral gas or dry air.
- Ensure that there is no residual process gas in the system nor in the feeder lines.

If the turbopump is to be shut down for more than a year:

- ➔ Remove turbopump from the system.
- ➔ Change the lubricant (see Section 8.1.).
- ➔ Close the high vacuum flange and evacuate the turbopump via the fore-vacuum flange.
- ➔ Vent turbopump via the venting connection with nitrogen or dry air.
- ➔ Close fore-vacuum and venting connection by blank flanging.
- ➔ Place the pump vertically on its rubber feet.
- ➔ In rooms with moist or aggressive atmospheres, the turbopump must be air-sealed in a plastic bag together with a bag of dessicant, e.g. silicagel.

#### 4.8. Operations With The DCU 001 / DCU 600

Operations with the DCU 001 or DCU 600 should be carried out in accordance with the relevant Operating Instructions PM 800 477 BN (DCU description) and PM 800 547 BN (operating the pump with the DCU).



Operations with the DCU 001/DCU 600, the remote plug 8d on the TC should be disconnected (please see Section 10.).

#### 4.9. Operations With The Remote Control Unit

(please refer to the table in Section 3.9.).

Remote control operations can be performed via the connection with the designation "REMOTE" on the TC 750. The connection is via a 10 pole screwed connector plug with the following arrangement:

- 1 - + 24V
- 2 - Input, venting
- 3 - Input, turbopump motor
- 4 - Input, pumping station
- 5 - Input, heating unit/reset
- 6 - Input, Standby
- 7 - Input, PWM
- 8 - Switching output 1: Rotation speed switchpoint
- 9 - Switching output 2: Collective malfunction message
- 10 - Mass

Inputs 2-6 are activated if they are connected with the +24 V on pin 1 (active high).



**On delivery there is a bridge between pin 1, pin 2, pin 3 and pin 4 on the TC 750 mating plug.**

When operations voltage is supplied and a successfully completed TC 750 self-test the turbopump and any connected backing pump will be started.

## Venting Release (Optional)

### Automatic venting

(works setting on the remote plug pin 2 high):

When the turbopump or pumping station is switched off the venting valve opens for the venting time of 3600 seconds (1 hour) when the venting frequency falls below 50% of the final rotation speed. In the event of a mains power failure if the venting frequency falls below 50% of the final rotation speed the venting valve opens and closes on attainment of 15% of the final rotation speed. When mains power is restored the venting process is interrupted.

### Venting OFF

(works setting on the remote plug pin 2 low):

Venting does not take place.

### Other venting modes:

Other venting modes can be selected via the DCU.

## Motor, Turbopump

When the pumping station is switched on and once the self test has been successfully completed (duration approximately 20 seconds), the turbopump is set in operation. During operations, the turbopump can be switched on and off while the pumping station is switched on.

## Pumping Station

Any connected pumping station components are started up (e.g. backing pump, venting valve, air cooling) and with simultaneous activation of the input "motor, turbopump" the turbopump is set in operation once the self test has been successfully completed (duration approximately 20 seconds).

## Heating/Reset

### Heating (optional)

Once the rotation speed switchpoint is attained the heating unit is switched on; when the rotation speed switchpoint is fallen below the heating unit is switched off.

### Reset

The heating input has two functions (please see Section 3.9, point 5 "Reset").

## Standby

The pump can be operated optionally at 66% of its nominal rotation speed (standby ON) or at its nominal rotation speed (standby OFF).

## Rotation Speed Setting Operations Via Input PWM

The supply of pulse width modulated signals (PWM) with a ground frequency of  $100 \text{ Hz} \pm 20\%$  with an amplitude of maximum 24 V and a touch ratio of 25-75% enables the rotation speed to be set in the range from 50-100% of the nominal rotation speed.

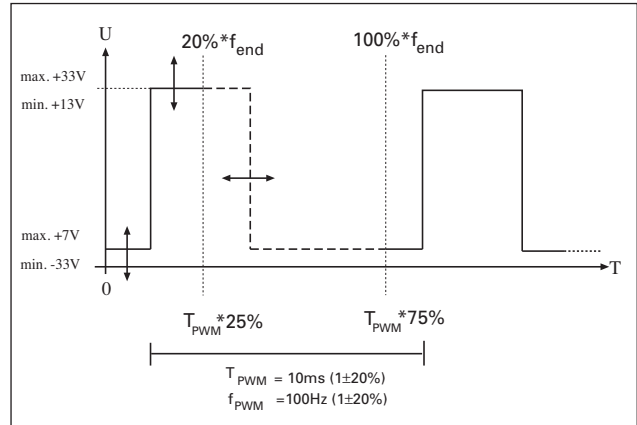

If no signal is present the pump runs up to its final rotation speed.

Available as accessories:

- A PWM adapter box for rotation speed setting operations for the turbopump.
- A Brake Unit TBU 600 which enables, in rotation speed setting mode, faster braking on turbopumps with TC 750.

## Switching Outputs

Switching outputs 1 and 2 can be loaded with a maximum 24 V / 50 mA per output. The following functions are assigned to the switching outputs:

**Switching output 1:** Active high when the rotation speed switchpoint is attained. The switchpoint for the turbopump is set at 80% of the nominal rotation speed. It can be used, for example, for a message "pump ready to operate".

**Switching output 2:** Active low with a malfunction - collective malfunction message

The connection of a relay is made between pin 10 (mass) and the respective switching output pin 8 or pin 9 (see Section 3.11. Connections Diagram).

## 5. Monitoring Operations

### 5.1. Operations Display Via LED

Certain operations modes of the turbopump and the TC 750 can be ascertained via the two integrated LEDs located on the front panel of the TC 750.

The following operations modes are displayed:

| LED           |            | Cause   |
|---------------|------------|---|
| I             | ⚡          |   |
| glows green   |            | <ul style="list-style-type: none"> <li>– Power unit OK</li> <li>– Function "pumping station ON" carried out</li> </ul>  |
| flashes green |            | <ul style="list-style-type: none"> <li>– Power unit OK</li> <li>– Pumping station OFF</li> </ul>  |
| blinks green  |            | <ul style="list-style-type: none"> <li>– Mains power supply failure</li> </ul>  |
|               | glows red  | <ul style="list-style-type: none"> <li>– Collective malfunction (for example, start-up time error, excess temperature, turbopump or TC 750, lubricant deficiency)</li> <li>– Switching output 2 active (low)</li> </ul> |
|               | blinks red | <ul style="list-style-type: none"> <li>– Warning (for example, earth leakage fault in the voltage supply, mains power supply failure)</li> </ul>  |

### 5.2. Turbopump Temperature Monitoring

Where impermissible motor temperatures are involved or the temperature of the casing is too high, the motor current is reduced. This can lead to dipping below the set rotation speed switchpoint and results in the turbomolecular pump being switched off.

LED on the TC 750 glows red: Collective malfunction.



Differentiated malfunction and warning signals are only possible with the use of the DCU.

## 6. What To Do In Case Of Breakdowns?

| Problem   | Possible Causes  | Remedy   |
|---|--|--|
| Pump doesn't start;<br>None of the integrated LEDs glow on the TC 750                                       | <ul style="list-style-type: none"> <li>• Power supply interrupted</li> <li>• Incorrect operations voltage supplied</li> <li>• Pins 1-3 and 1- 4 on the remote-plug not connected</li> <li>• No supply of operations voltage</li> <li>• Defect TC 750</li> <li>• Reduction in the voltage in the cable</li> </ul>   | <ul style="list-style-type: none"> <li>• Check fuse in the power unit</li> <li>• Check plug contacts on the power unit</li> <li>• Check power unit feeder line</li> <li>• Check voltage on the power unit (140 V DC) at connection X2</li> <li>• Supply correct operations voltage</li> <li>• Connect pins 1-3 and 1- 4 on the remote plug</li> <li>• Check plug contacts on the power unit</li> <li>• Inform PFEIFFER Service of need for repair</li> <li>• Use suitable cable</li> </ul>   |
| Pump doesn't attain nominal rotation speed within the set start-up time;<br>Pump cuts out during operations | <ul style="list-style-type: none"> <li>• Fore-vacuum pressure too high</li> <li>• Leak or too high levels of gas load</li> <li>• Rotor sluggish caused by defective bearing</li> <li>• TC start-up time too short</li> <li>• Thermal overloading caused by: <ul style="list-style-type: none"> <li>– Insufficient water flow</li> <li>– Insufficient air supply</li> <li>– Fore-vacuum pressure too high</li> <li>– Ambient temperature too high</li> </ul> </li> <li>• Lubricant or lubricating pump dirty</li> <li>• Lubricant deficiency</li> </ul> | <ul style="list-style-type: none"> <li>• Check backing pump function</li> <li>• Check seals</li> <li>• Seek leak and repair</li> <li>• Supply of process gas too high; reduce</li> <li>• Check bearing (noises?): Request PFEIFFER Service to replace</li> <li>• Set longer start-up time with the DCU or PC</li> <li>• Ensure free flow</li> <li>• Ensure adequate air supply</li> <li>• Reduce fore-vacuum pressure</li> <li>• Reduce ambient temperature</li> <li>• Carry out lubricant change as per Section 8.1. or clean the lubricating pump as per Section 8.2.</li> <li>• Check lubricant and replace as necessary</li> </ul> |
| Pump doesn't attain final pressure  | <ul style="list-style-type: none"> <li>• Pump dirty</li> <li>• Leak in vacuum chamber, lines or pump</li> </ul>  | <ul style="list-style-type: none"> <li>• Bake out pump</li> <li>• If seriously contaminated: Request PFEIFFER Service to clean</li> <li>• Seek leak starting with vacuum chamber</li> <li>• Repair leak</li> </ul>   |
| Unusual operating noises  | <ul style="list-style-type: none"> <li>• Bearing damaged</li> <li>• Rotor damaged <ul style="list-style-type: none"> <li>– Foreign particles in the blade area</li> </ul> </li> <li>• Splinter shield (if fitted) not seated firmly</li> </ul>   | <ul style="list-style-type: none"> <li>• Inform PFEIFFER Service of need for repair</li> <li>• Inform PFEIFFER Service of need for repair</li> <li>• Check seat of splinter shield (see Section 3.2.)</li> </ul>   |
| Red LED on the TC 750 glows   | <ul style="list-style-type: none"> <li>• Collective malfunction</li> </ul>   | <ul style="list-style-type: none"> <li>• Reset via mains OFF/ON or remote pin 5</li> <li>• Different malfunction display with a DCU possible<sup>1)</sup></li> </ul>   |
| Red LED on the TC 750 blinks  | <ul style="list-style-type: none"> <li>• Warning from: <ul style="list-style-type: none"> <li>– Mains power failure</li> <li>– Supply voltage short circuit to earth</li> </ul> </li> </ul>  | <ul style="list-style-type: none"> <li>• Different warning display with a DCU is possible<sup>1)</sup></li> <li>• Check power unit voltage</li> <li>• Check the power unit mains connection</li> <li>• Check the power unit voltage for short circuit to earth</li> </ul>  |

1) Without a DCU inform PFEIFFER Service to check the cause of trouble.

## 7. Service

### Do make use of our service facilities

In the event that repairs are necessary a number of options are available to you to ensure any system down time is kept to a minimum:

- Have the pump repaired on the spot by our PFEIFFER Service Engineers;
- Return the pump to the manufacturer for repairs;
- Replace the pump.

Local PFEIFFER representatives can provide full details.



Please take into account that where PFEIFFER Service replacement service is involved the standard operating parameters are always pre-set.

If your application requires different parameters, please modify accordingly.



The turbopump and the Electronic Drive Unit TC 750 form a single unit and must therefore be returned complete for repair purposes. Before returning the unit it should be ensured that the power unit is not the cause of the malfunction (please see Section 5. for checking the power unit).

### Before returning:

- ➔ Dismantle all accessories.
- ➔ Please attach a clearly visible notice "Free of harmful substances" (both on the unit and also on the delivery note and any accompanying letters).

"Harmful substances" are substances and preparations as defined in the current, local, dangerous substances regulations; in the U.S.A. as "materials in accordance with the Code of Federal Regulations (CFR) 49 Part 173.240 Definition and Preparation". We will carry out the decontamination and invoice this work to you if you have not attached this note.

This also applies where the operator does not have the facilities to carry out the decontamination work.

### Fill out the declaration of contamination

- ➔ In every case the "Declaration of Contamination" must be completed diligently and truthfully.
- ➔ A copy of the completed declaration must accompany the unit; any additional copies must be sent to your local PFEIFFER Service Center.

Please get in touch with your local PFEIFFER representatives if there are any questions regarding contamination.



Decontaminate units before returning or possible disposal. Do not return any units which are microbiologically, explosively or radioactively contaminated.

### Returning contaminated units

If contaminated have to be returned for maintenance/repair, the following instructions concerning shipping must be followed:

- ➔ Neutralise the pump by flushing with nitrogen or dry air.
- ➔ Seal all openings to the air.
- ➔ Seal pump or unit in suitable protective foil.
- ➔ Ship units only in appropriate transport containers.



Repair orders are carried out according to our general conditions of sale and supply.

If repairs are necessary, please send the pump together with a short damage description to your nearest PFEIFFER Service Center.

### Contact addresses and telephone hotline

Contact addresses and telephone numbers can be found on the back cover of these operating instructions.

## 8. Maintenance



No liability for personal injury nor material damage will be accepted for damages and operational interruptions which have been caused by improper maintenance; in addition, all guarantees become invalid.

You can change the lubricant yourself. Your local PFEIFFER Service can advise you regarding cleaning procedures and any other maintenance and service work.



Ensure no mechanical forces act on the Electronic Drive Unit TC 750.

### 8.1. Replacing The Lubricant

The lubricant should be replaced at least once a year. Where extreme operating conditions or unclean processes are involved, the replacement interval should be checked with your PFEIFFER Service Center.



Lubricant screw 72 may only be opened if the turbopump has been vented to atmospheric pressure.



Detach the lubricating pump is required in order to carry out a lubricant change.

- ➔ Switch off the turbopump, vent to atmospheric pressure (see Section 4.6.) and allow to cool as necessary.
- ➔ Remove the the lubricating pump from the turbopump as described in Section 8.2..
- ➔ Unscrew lubricant drain screw 72 and drain lubricant into a suitable container.



Lubricants can contain toxic substances from the medium pumped. Lubricant must be disposed of in accordance with the respective regulations. Safety instructions data sheet for the lubricant on request.

- ➔ Screw back in the lubricant drain screw 72 with the O-ring 75.
- ➔ Unscrew lubricant filler screw 71. Using the syringe provided inject approximately 40 cm<sup>3</sup> of lubricant (included in the delivery) as per the rating plate.



Where the set-up position is vertical or horizontal the maximum lubricant level in the sight glass is the lower edge of lubricant filler screw 71.

#### Filling in the lubricant

- A Syringe
- 71 Lubricant filler screw
- 72 Lubricant drain screw
- 73 Sight glass
- 75 O-ring

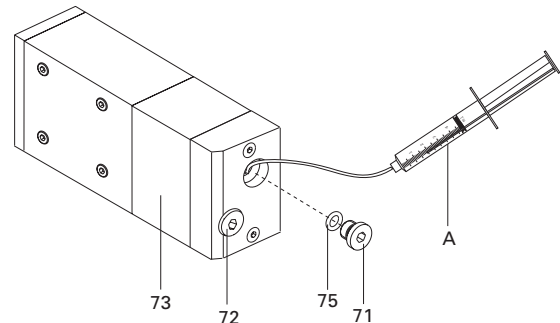

It is essential to ensure that the lubricating pump is not over-filled with lubricant. Overfilling will cause the excess lubricant to be secreted from the hole for the lubricant filler screw 71.

- ➔ Screw in lubricant filler screw 71 with the O-ring 75.
- ➔ Re-fit the lubricating pump to the turbopump.

## 8.2. Cleaning The Lubricating Pump

If, after a malfunction on account of insufficient lubricant, the pump no longer accelerates to the operating rotation speed, the lubricating pump has to be cleaned.

- ➔ Switch off the turbopump, vent to atmospheric pressure (please see Section 4.6.) and allow to cool as necessary.
- ➔ Unscrew the socket cap screws 83 (three pieces) from the lubricating pump cover 78 and remove the lubricating pump from the turbopump.

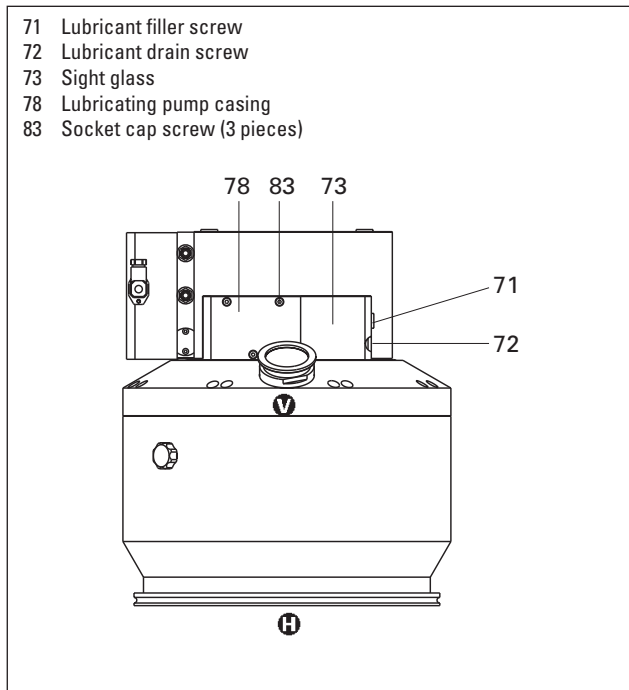

Dismantle the lubricating pump as follows and clean:

- ➔ Drain lubricant as described under Section 8.1. and dispose of.
  - ➔ Screw in lubricant drain screw 72 with O-ring 75.
  - ➔ Unscrew screws 87 (two pieces) and remove the sight glass 73 and the cover 84. Take care with O-ring 74.
  - ➔ Draw out bearing mounting with rotor 76 and sieve 103 from lubricating pump casing 78.
  - ➔ Remove pin 80 with pointed pliers and then remove floater 79 from the lubricating pump casing 78.
  - ➔ Take out the circlip 104 and the sieve 105.
  - ➔ Clean all parts with pure alcohol. If necessary, the sieve 105 must be changed.
  - ➔ Clean the borings in the lubricating pump casing 78 with a clean, fluff-free cloth.
  - ➔ Re-assemble the lubricating pump in reverse order to dismantling.
- Caution:** Ensure correct positioning of the O-rings. Floater 79 must be inserted into lubricating pump casing 78 with the thinner end first.
- ➔ Fill up with lubricant (approximately 40 cm<sup>3</sup>) in accordance with Section 8.1.
  - ➔ Fit the lubricating pump to the turbopump.

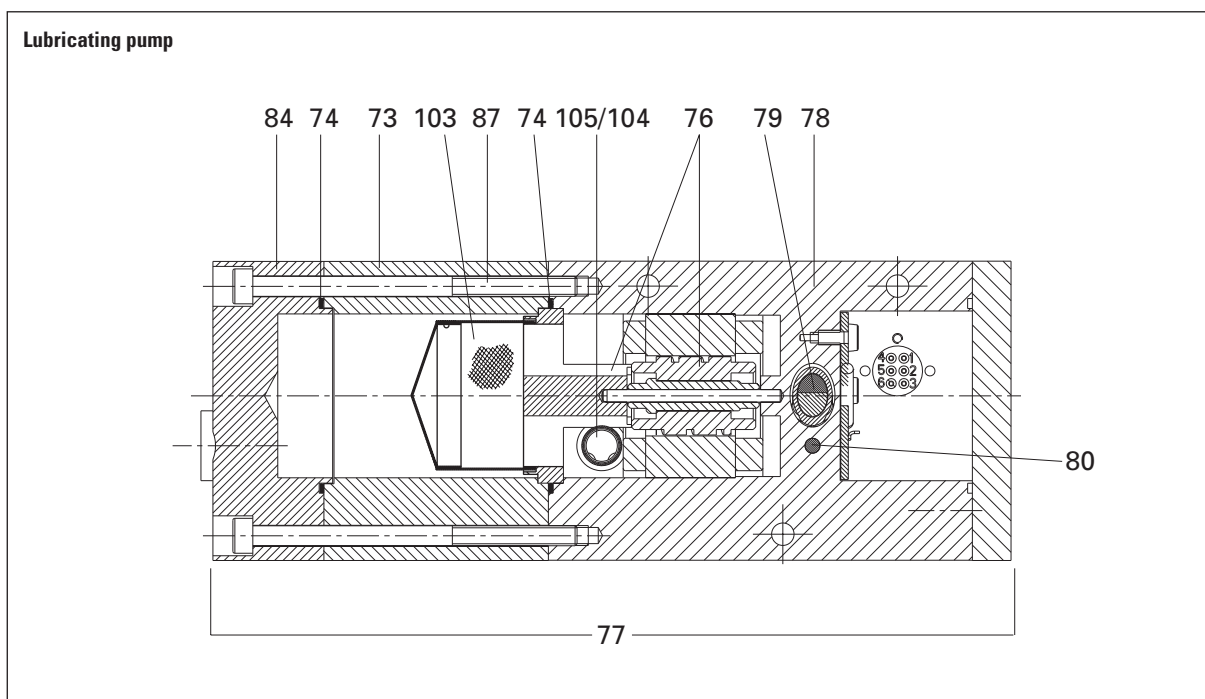

## Dismatle the lubricating pump

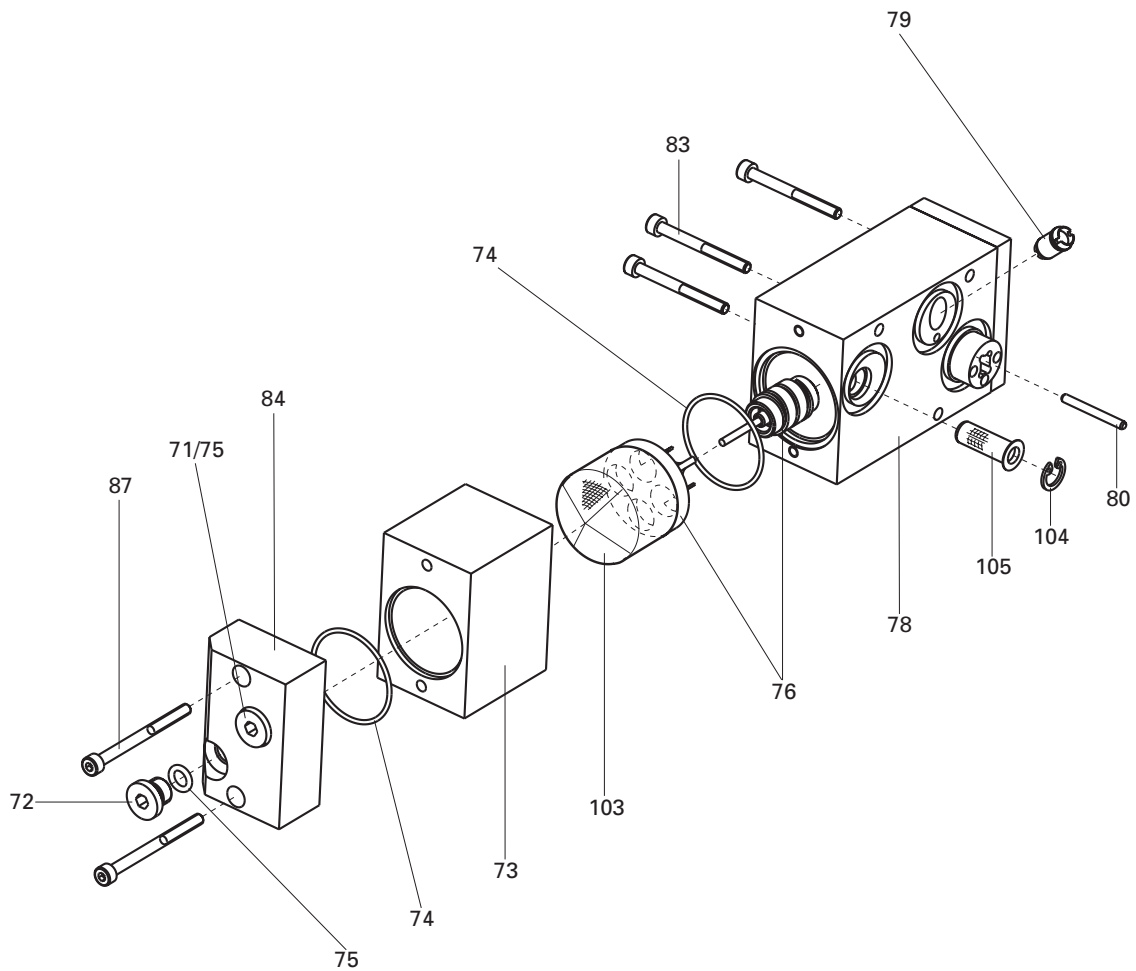

### Lubricating pump

- 71 Lubricant filler screw
- 72 Lubricant drain screw
- 73 Sight glass
- 74 O-ring
- 75 O-ring
- 76 Bearing mounting with rotor
- 77 Lubricating pump (complete)
- 78 Lubricating pump casing
- 79 Floater
- 80 Pin
- 83 Socket cap screw (3 pieces)
- 84 Cover
- 87 Socket cap screw (2 pieces)
- 103 Sieve
- 104 Circlip
- 105 Sieve

## 9. Technical Data

| Feature   | Unit            | TPH 2101 U P<br>TPH 2101 U P C             |              |
|---|-----------------|--|--------------|
| Connection nominal diameter:<br>Inlet<br>Outlet<br>Venting connection                           |                 | DN 200 ISO-K<br>DN 40 ISO-KF<br>G 1/8"     | DN 250 ISO-K |
| Nominal rotation speed  | 1/min           | 31 500                                     |              |
| Standby rotation speed  | 1/min           | 21 000                                     |              |
| Start-up time (up to 90% of the nominal rotation speed fore-vacuum pressure $\leq 0.1$ mbar)    | min             | 8  |              |
| Noise level   | dB (A)          | 47   |              |
| Final pressure, backing pump  | mbar            | $\leq 0.2$                                 |              |
| Maximum permissible rotor temperature   | °C              | 120  |              |
| Permissible heat radiation power  | W               | 80   |              |
| Volume flow rate for:   |                 |  |              |
| Nitrogen N <sub>2</sub>   | l/s             | 1400                                       | 1900         |
| Helium He   | l/s             | 1700                                       | 1900         |
| Hydrogen H <sub>2</sub>   | l/s             | 1650                                       | 1850         |
| Compression ratio for:  |                 |  |              |
| N <sub>2</sub>  |                 | $> 10^8$                                   |              |
| He  |                 | $2 \cdot 10^5$                             |              |
| H <sub>2</sub>  |                 | $3 \cdot 10^4$                             |              |
| Maximum fore-vacuum pressure  |                 |  |              |
| N <sub>2</sub>  | mbar            | 1.5  |              |
| He  | mbar            | 1  |              |
| H <sub>2</sub>  | mbar            | 0.5  |              |
| Maximum gas throughput <sup>1) 2) 3)</sup><br>with HV pressure of 0.1 mbar                      |                 |  |              |
| N <sub>2</sub>  | mbar/l/s        | approx. 25                                 |              |
| Ar  | mbar/l/s        | approx. 25                                 |              |
| with nominal rotation speed (water cooling)   |                 |  |              |
| N <sub>2</sub>  | mbar/l/s        | 15.0                                       | 15.0         |
| Ar  | mbar/l/s        | 14.5                                       | 14.5         |
| with voltage range 90 - 132 VAC   |                 |  |              |
| N <sub>2</sub>  | mbar l/s        | 8.1  | 8.1          |
| Vertex power characteristics lines <sup>4)</sup>  |                 |  |              |
| A   | W / Hz          | 750 / 525                                  |              |
| B   | W / Hz          | 750 / 525                                  |              |
| C   | W / Hz          | 750 / 525                                  |              |
| D   | W / Hz          | 750 / 525                                  |              |
| Final pressure <sup>5)</sup><br>with rotary vane vacuum pump<br>with UniDry <sup>TM</sup> 050-4 | mbar<br>mbar    | $< 1 \cdot 10^{-9}$<br>$< 1 \cdot 10^{-9}$ |              |
| Lubricant<br>Type<br>Filling volume   | cm <sup>3</sup> | F3<br>40                                   |              |
| Cooling water consumption<br>with water at 15 °C <sup>6)</sup><br>Cooling water temperature     | l/h<br>°C       | 100<br>5 - 25                              |              |
| Power consumption:<br>TMS heating<br>Weight<br>Permissible magnetic field                       | W<br>kg<br>mT   | 39   | 1900<br>38   |
| Permissible magnetic field  | mT              | 7  |              |
| Connection voltage<br>Current consumption<br>Power<br>Protection class <sup>7)</sup>            | VDC<br>A<br>W   | 140 ± 5%<br>5.4<br>750<br>IP 30            |              |
| Relative humidity   | %               | 5 - 85 non condensing                      |              |

- 1) In TMS operations the maximum gas throughput is reduced with increasing TMS temperature.  
2) If the pump is to be operated with more than 50% of the maximum gas load, sealing gas must be used.  
3) Backing pump 120 m<sup>3</sup>/h.

- 4) For gas typ characteristics lines please refer to Section 4.4. Where pumps for TMS operations are involved, the corner points reduce according to the temperature; the values are available on request.  
5) In accordance with DIN 28 428 the final pressure of a turbomolecular pump is that pressure which is attained in a measuring dome 48 hours after baking out.  
6) With maximum gas throughput.  
7) Protection class IP 54 is afforded for the Electronic Drive Unit TC 600 by retrofitting a cover plate (accessory).

## 9.1. Dimensions Diagram

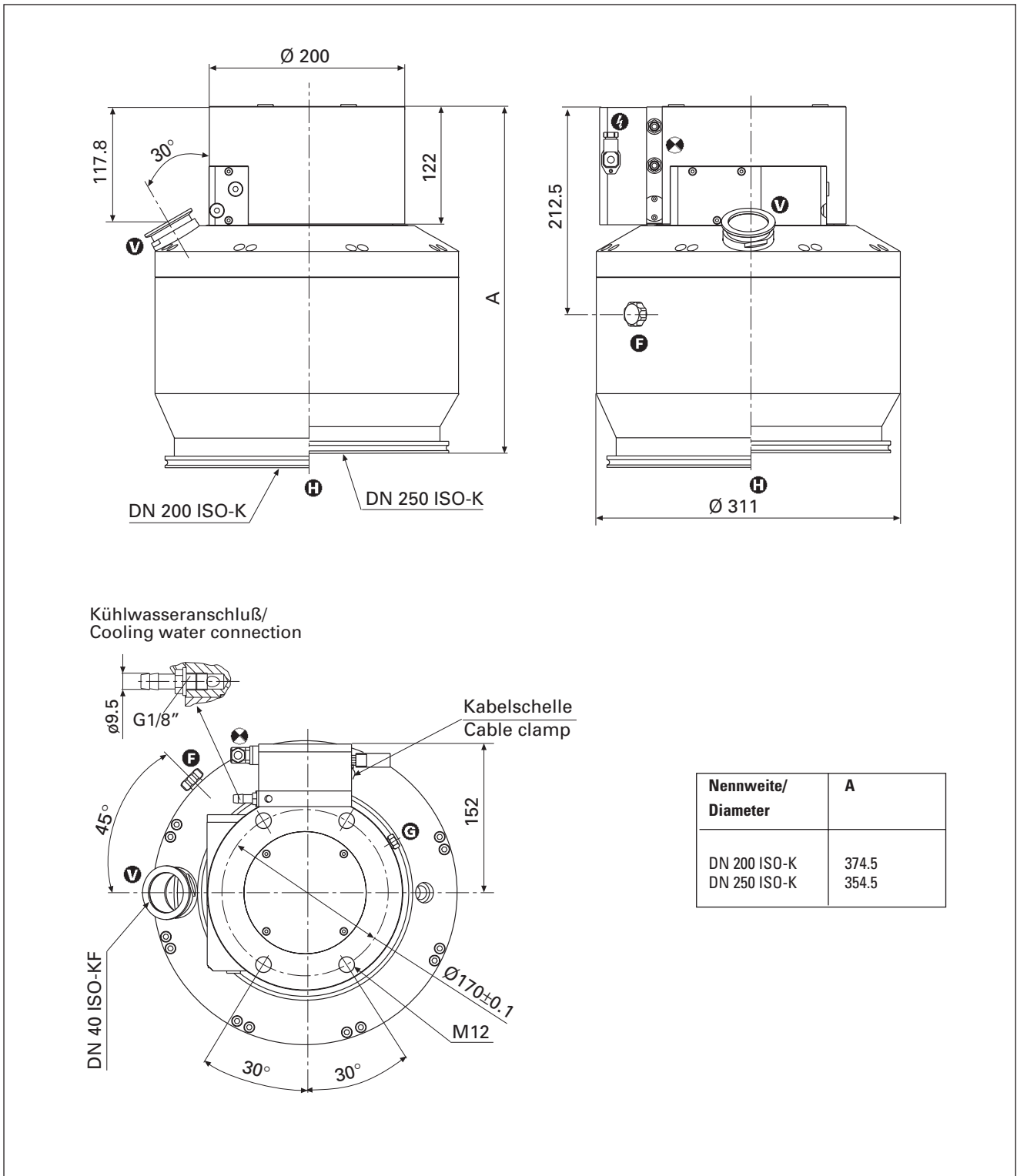

## 10. Spare Parts

---

| Pos. | Description                                      | Pieces | Size     | Number        | Comments | Ordering Quantity |
|------|--|--------|----------|---------------|----------|-------------------|
|      | <b>Spare parts TPH 2101 U P / TPH 2101 U P C</b> |        |          |               |          |                   |
|      | Set of seals TPH 2101 U P                        | 1      |          | PM 053 459 -T |          |                   |
|      | TPH 2101 U P C                                   | 1      |          | PM 053 460 -T |          |                   |
| 8d   | Remote plug                                      | 1      |          | P 0920 668 E  |          |                   |
| 17   | USIT-ring  | 3      |          | P 3529 133 -A |          |                   |
| 71   | Lubricant filler screw                           | 1      |          | N 3191 382 X  |          |                   |
| 72   | Lubricant drain screw                            | 1      |          | N 3191 382 X  |          |                   |
| 73   | Sight glass                                      | 1      |          | PM 093 203    |          |                   |
| 74   | O-ring   | 2      | 35 x 1.5 | P 4070 578 PP |          |                   |
| 75   | O-ring   | 2      | 6 x 2.2  | P 4070 088 PV |          |                   |
| 77   | Lubricating pump (complete)                      | 1      | (for F3) | PM 083 868 -T |          |                   |
| 79   | Floater  | 1      |          | PM 033 306 -X |          |                   |
| 105  | Sieve  | 1      |          | PK 300 006    |          |                   |

Spare parts

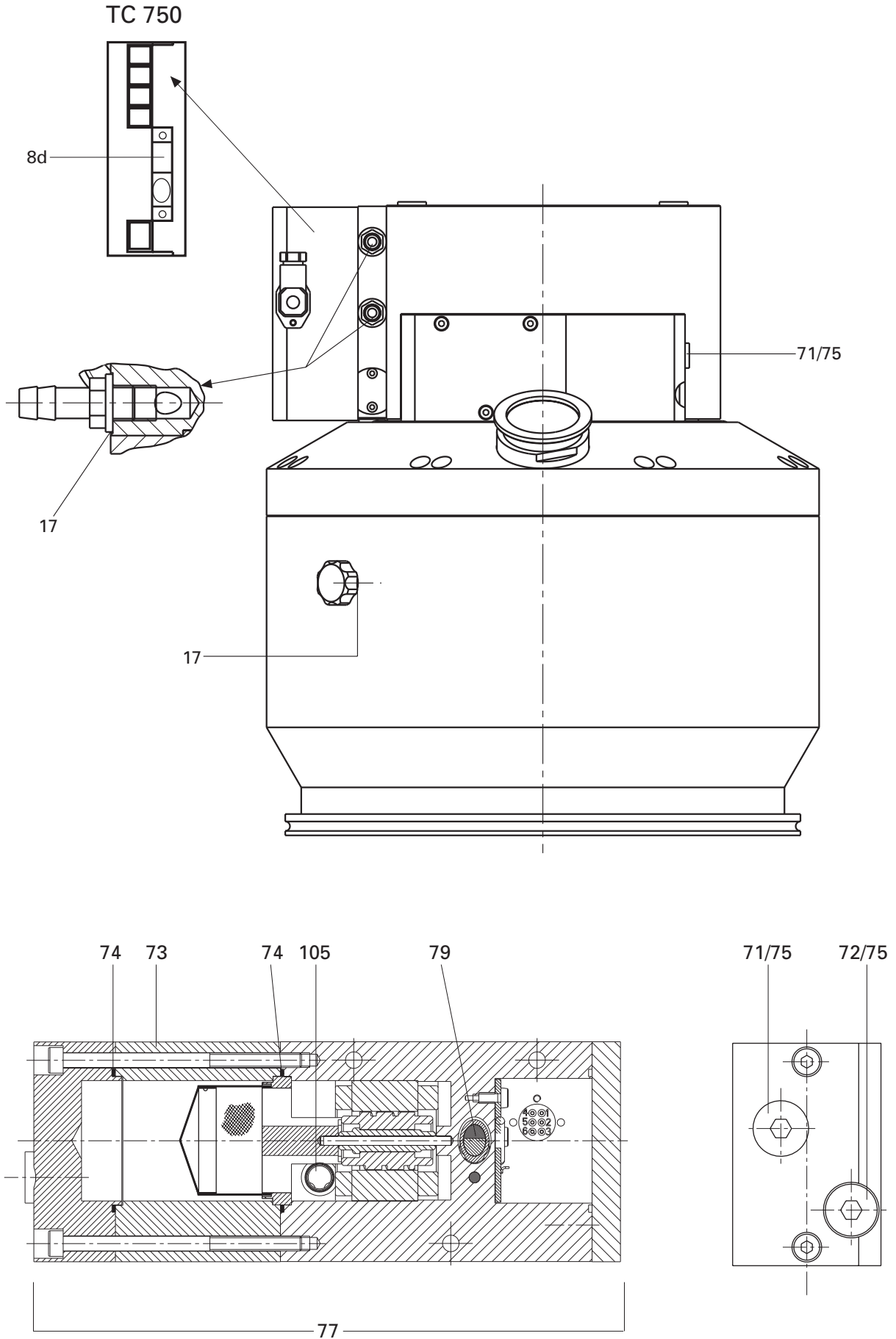

## 11. Accessories

| Description   | Size  | Number  | Comments/<br>Operating Instructions  | Order Quantity |
|---|---|---|--|----------------|
| <b>Components for cooling</b>   |   |   |  |                |
| Dirt trap<br>Recycled Water Cooling Unit TZK 2000   | R 3/8"<br>230 V, 50 Hz                            | P 4161 300 2R<br>PM Z01 240   | PM 800 369 BN  |                |
| <b>Components for venting</b>   |   |   |  |                |
| Venting Valve TVF 005, without current closed<br>Drying Unit TTV 001<br>(filled with zeolite)   | 24 VDC  | PM Z01 135<br>PM Z00 121  | PM 800 507 BN<br>PM 800 022 BN   |                |
| Venting flange  | DN 10 ISO-KF                                      | PM 033 737 -T   |  |                |
| <b>Other accessories</b>  |   |   |  |                |
| Connecting cable, TC 750-TPS/DCU  | 3 m   | PM 051 103 GT   | other lengths on request   |                |
| Power Unit<br>– TPS 600; for fitting to walls<br>or standard runners<br>– TPS 600; 19" insert unit<br>– DCU 600; 19" insert unit with<br>Operating and Display Control Unit (DCU) |   | PM 041 815 -T<br>PM 041 821 -T<br><br>PM C01 697                                  | PM 800 521 BN<br>PM 800 521 BN<br><br>PM 800 477 BN                            |                |
| Mains cable<br>Safety plug<br>UL plug<br>UL plug  | 230 V<br>208 V<br>115 V                           | P 4564 309 ZA<br>P 4564 309 ZF<br>P 4564 309 ZE                                   |  |                |
| Operating and Display Control Unit DCU 001  |   | PM 041 816 -T   | PM 800 477 BN  |                |
| Relay box, backing pump 1 phase 16A<br>Safety plug<br>UL plug<br>UL plug  | 230 V<br>208 V<br>115 V                           | PM 041 920 -T<br>PM 041 921 -T<br>PM 041 922 -T                                   | PM 800 544 BN<br>PM 800 544 BN<br>PM 800 544 BN                                |                |
| PWM adapter box<br>Brake Unit TBU 600<br>Level Converter RS 232/485<br>Cover plate for TC 750 (IP 54)<br>Profibus-DP gateway TIC 250  |   | PM 051 028 -U<br>PM 051 368 -T<br>PM 051 054 -X<br>PM 051 327 -T<br>PM 051 257 -T | PM 800 563 BN<br>PT 800 018 BN<br>PM 800 549 BN<br>PT 0024 BN<br>PM 800 599 BN |                |
| Vibration compensator, TPH  | DN 200 ISO-K<br>DN 250 ISO-KF                     | PM 006 668-X<br>PM 006 670 -X   |  |                |
| Protective mesh   | DN 200<br>DN 250                                  | PM 016 108 -U<br>PM 016 107 -U  |  |                |
| Splinter shield   | DN 200<br>DN 250                                  | PM 016 110 -U<br>PM 016 109 -U  |  |                |
| Sealing ring, TPH   | DN 200<br>DN 250                                  | PF 303 120 -T<br>PF 303 125 -T  |  |                |
| Collar flange with retaining ring, TPH  | DN 200-F<br>DN 250-F                              | PF 307 120 -T<br>PF 307 125 -T  |  |                |
| Hose nipple<br>Sealing gas valve<br>Fore-Vacuum Safety Valve TVV 001  | DN 16 ISO-KF-10<br>DN 10 ISO-KF<br>115 V<br>230 V | PF 144 020<br>PM Z01 142<br>PM Z01 206<br>PM Z01 205<br>PM 006 296 -U             | for use please see Section 3.9.<br>PM 800 229 BN<br>PM 800 263 BN              |                |
| Syringe   |   |   |  |                |

### 11.1. Lubricant

| Lubricant | Amount           | Order Number                   | Order Quantity |
|-----------|------------------|--------------------------------|----------------|
| F3        | 0.05 l<br>0.25 l | PM 006 336 -T<br>PM 006 313 -T |                |

When ordering accessories and spare parts please be sure to state the full part number. When ordering spare parts please state additionally the unit type and unit number (see rating plate). Please use this list as an order form (by taking a copy).

## Declaration of Contamination of Vacuum Equipment and Components

The repair and/or service of vacuum components will only be carried out if a correctly completed declaration has been submitted. Non-completion will result in delay.

The manufacturer could refuse to accept any equipment without a declaration.

**This declaration can only be completed and signed by authorised and qualified staff:**

**1. Description of component:**

- Equipment type/model: \_\_\_\_\_
- Code No.: \_\_\_\_\_
- Serial No.: \_\_\_\_\_
- Invoice No.: \_\_\_\_\_
- Delivery Date: \_\_\_\_\_

**2. Reason for return:**

\_\_\_\_\_

\_\_\_\_\_

\_\_\_\_\_

\_\_\_\_\_

**3. Equipment condition**

- Has the equipment been used?  
yes  no
- What type of pump oil was used?  
\_\_\_\_\_
- Is the equipment free from potentially harmful substances?  
yes  (go to section 5)  
no  (go to section 4)

**4. Process related contamination of equipment**

- toxic yes  no
- corrosive yes  no
- microbiological hazard\*) yes  no
- explosive\*) yes  no
- radioactive\*) yes  no
- other harmful substances yes  no

\*) We will not accept delivery of any equipment that has been radioactively or microbiologically contaminated without written evidence of decontamination!

Please list all substances, gases and by-products which may have come into contact with the equipment:

| Tradename<br>Product name<br>Manufacturer | Chemical name<br>(or Symbol) | Danger class | Precautions associated<br>with substance | Action if spillage or human<br>contact |
|---|------------------------------|--------------|--|--|
| 1.  |                              |              |  |  |
| 2.  |                              |              |  |  |
| 3.  |                              |              |  |  |
| 4.  |                              |              |  |  |
| 5.  |                              |              |  |  |

### 5. Legally Binding Declaration

I hereby declare that the information supplied on this form is complete and accurate. The despatch of equipment will be in accordance with the appropriate regulations covering Packaging, Transportation and Labelling of Dangerous Substances.

Name of Organisation: \_\_\_\_\_

Address: \_\_\_\_\_ Post code: \_\_\_\_\_

Tel.: \_\_\_\_\_

Fax: \_\_\_\_\_ Telex: \_\_\_\_\_

Name: \_\_\_\_\_

Job title: \_\_\_\_\_

Date: \_\_\_\_\_ Company stamp: \_\_\_\_\_

Legally binding signature: \_\_\_\_\_

## **Herstellererklärung Manufacturer's Declaration**

im Sinne folgender EU-Richtlinien:  
*pursuant to the following EU directives:*

- **Maschinen/Machinery 98/37/EG**
- **Elektromagnetische Verträglichkeit/Electromagnetic Compatibility 89/336/EWG**
- **Niederspannung/Low Voltage 73/23/EWG**

Hiermit erklären wir, daß das unten aufgeführte Produkt zum Einbau in eine Maschine bestimmt ist und daß deren Inbetriebnahme so lange untersagt ist, bis festgestellt wurde, daß das Endprodukt den Bestimmungen der EU-Richtlinie 98/37/EG, Anhang II B entspricht.

Wir bestätigen Konformität mit der EU-Richtlinie über elektromagnetische Verträglichkeit 89/336/EWG und der EU-Niederspannungsrichtlinie 73/23/EWG.

*We hereby certify that the product specified below is intended for installation in a machine which is forbidden to be put into operation until such time as it has been determined that the end product is in accordance with the provision of EU Directive 98/37/EEC, Annex II B.*

*We certify conformity with EU Electromagnetic Compatibility Directive 89/336/EEC and EU Low Voltage Directive 73/23/EEC.*

**Produkt/Product:**

**TPH 2101 U P**

**TPH 2101 U P C**

Angewendete Richtlinien, harmonisierte Normen und angewendete, nationale Normen:

*Guidelines, harmonised standards, national standards in which have been applied:*

**EN 292-1**  
**EN 292-2**

**EN 294**  
**EN 1012-2**

**EN 61010**

Unterschrift/Signature:



Pfeiffer-Vacuum GmbH  
Berliner Strasse 43  
35614 Asslar  
Germany

(W. Dondorf)  
Geschäftsführer  
Managing Director

Herst.I./2000

# Adressen • Addresses

## Argentina

ARO S.A., Av. Belgrano 369,  
1092 Buenos Aires, telephone +54 / 11 4331 5766,  
telefax +54 / 11 4331 3572

## Australia

Sciteck Australia Pty. Ltd., Suite 1B,  
10-18 Cliff Street, Milsons Point, NSW 2061,  
telephone +61 / 2 9954 1925, telefax +61 / 2 9954 1939

## Austria

Pfeiffer Vacuum Austria GmbH  
Diefenbachgasse 35, A-1150 Wien,  
telephone +43 / 1 8941 704, telefax +43 / 1 8941 707  
Service Hotline: +43 / 1 8941704

## Branch Office, Czech Republic

Pfeiffer Vacuum Austria GmbH, Branch Prague  
Zvonarska 885  
CZ-156 00 Praha 5  
telephone + 420/2 900 42981, telefax + 420/2 579 23014

## Belgium / Luxemburg

Pfeiffer Vacuum Belgium N.V./S.A.  
Luxemburgstraat 5, B-9140 Temse  
telephone +32 / 3 710 5920, telefax +32 / 3 710 5929  
Service Hotline: +32 / 3 710 5922

## Brazil

Elmi Tec  
Assistencia Técnica e Representação S/C Ltda.  
Rua Bernadino de Campos, 551-Brooklin  
CEP 04620-002 São Paulo, SP - Brasil  
telephone +55 / 11 5532 0740, telefax +55 / 11 5535 3598

## Chile

BERMAT S.A., Coyancura 2283, Oficina 601  
Providencia, P.O. Box 9781, Santiago  
telephone +56 / 2 231 8877, telefax +56 / 2 231 4294

## Colombia

Arotec Colombiana S.A., Carrera 16 No. 36-89  
P.O. Box 050 862, Santafe de Bogota / D.C.  
telephone +57 / 1 288 7799, telefax +57 / 1 285 3604

## Denmark

Pfeiffer Vacuum Scandinavia AB, Vesterengen 2,  
DK-2630 Taastrup,  
telephone +45 / 43 52 38 00, telefax +45 / 43 52 38 50

## France

Pfeiffer Vacuum France SAS  
45, rue Senouque, BP 139  
F-78531 BUC Cedex  
telephone +33 / (0)1 30 83 04 00,  
telefax +33 / (0)1 30 83 04 04

## Germany

Pfeiffer Vacuum GmbH,  
Berliner Strasse 43, D-35614 Asslar  
telephone +49 / 6441 802 400, telefax +49 / 6441 802 399  
Service Hotline: +49 / 6441 802 333

## Great Britain

Pfeiffer Vacuum Ltd.  
2-4 Cromwell Business Centre  
Howard Way, Interchange Park  
Newport Pagnell, MK16 9QS, United Kingdom  
telephone +44 / 1 908 500615, telefax +44 / 1 908 500616

## Greece

Analytical Instruments S.A., 1 Mantzarou St.,  
GR-15451 Athens,  
telephone +30 / 10 674 8973-7, telefax +30 / 10 674 8978

## Hong Kong

Pfeiffer Vacuum Asia Ltd.  
Units 06-07, 17/F, Workingfield Commercial Building,  
408-412 Jaffe Road, Hong Kong  
telephone +852 2575 6688, telefax +852 2575 6993

## India

Pfeiffer Vacuum India Ltd.  
25-E Nicholson Road, Tarbund  
Secunderabad 500 009,  
telephone +91 / 40 775 0014, telefax +91 / 40 775 7774

## Israel

ODEM Scientific Applications Ltd.  
9 Hamazmera St., P.O.B. 2001 Nes Ziona  
telephone +972 8 938 0333, telefax +972 8 938 0334

## Italy

Pfeiffer Vacuum Italia S.p.a.  
Via San Martino, 44 I-20017 RHO (Milano)  
telephone +39 / 2 93 99 051, telefax +39 / 2 93 99 05 33

## Japan

Hakuto Co. Ltd., C.P.O. Box 25,  
Vacuum Scientific Instruments Division  
C.P.O. Box 25, Tokyo 100-91  
telephone +81 / 3 32 258 910, telefax +81 / 3 32 259 011

## Korea

Pfeiffer Vacuum Korea Ltd.,  
703 Ho, 853-1, Hankuk Mulru, Dongchonri, Suzi-Eup,  
449-843 Yong-in City, Kyungkido  
telephone +82 / 31 266 0741, telefax +82 / 31 266 0747

## Netherlands

Pfeiffer Vacuum Nederland BV  
Veldzigt 30a, NL-3454 PV De Meern,  
telephone +31 / 30 6666050, telefax +31 / 30 6662794

## Peru

Ing. E. Brammertz s.r.l., José Pardo 182,  
Apartado 173, PE-18 Miraflores,  
telephone +51 / 1 445 8178, telefax +51 / 1 445-1931

## Poland

Softtrade Sp.z.o.o, ul. Grunwaldzka 391,  
PL-60-173 Poznan, telephone +48 / 61 8677 168,  
telefax +48 / 61 8677 111

## Portugal

Unilaser Lda, Taguspark  
Núcleo Central, sala nº 268,  
Estrada Cacém Porto Salvo, P-2780 Oeiras  
telephone +351 / 1 421 7733, telefax +351 / 1 421 7744

## Singapore

APP Systems Services Pte Ltd, 11, Toh Guan Road East,  
#03-01 APP Enterprise Building, Singapore 608603,  
telephone +65 / 6425 6611, telefax +65 / 6560 6616

## Spain

Tecnovac  
Tecnología de Vacío S.L.,  
Sector Literatos, 38 - Local 1  
ES-28760 Tres Cantos (Madrid)  
telephone +34 / 91 804 11 34, telefax +34 / 91 804 30 91

## Sweden

Pfeiffer Vacuum Scandinavia AB  
Johanneslundsvägen 3  
SE-194 61 Upplands Väsby  
telephone +46 / 8 590 748 10, telefax +46 / 8 590 748 88

## Switzerland

Pfeiffer Vacuum Schweiz S.A.  
Förribuckstraße 30, CH-8005 Zürich  
telephone +41 / 1 444 2255, telefax +41 / 1 444 2266

## South Africa

Labotec Pty Ltd., P.O. Box 6553,  
Halfway House  
1685 Midrand  
telephone +27 / 11 315 5434, telefax +27 / 11 315 5882

## Taiwan

HAKUTO Taiwan Ltd. Hsinchu office No. 103,  
Hsien Chen 11th Street, Chupei,  
HsinChu County, Taiwan, R.O.C.  
(zip/postal code: 302)  
telephone +886 / 3 554 1020, telefax +886 / 3 554 0867

## Thailand

Hakuto (Thailand) Ltd.  
18th Floor, Chokchai Int'l Bldg.  
690 Sukhumvit Road  
Klongton, Klongtoey  
Bangkok 10110  
telephone +662 / 259 6244, telefax +662 / 259 6243

## U.S.A.

Pfeiffer Vacuum, Inc.  
24 Trafalgar Square  
Nashua, NH 03063-1988  
USA  
telephone +1 / 603 578 6500, telefax +1 / 603 578 6550

## Venezuela

Secotec S.A., Apartado 3452, Caracas 1010-A,  
telephone +58 / 212 573 8687, telefax +58 / 212 573 1932

## Other countries

AVI - Applied Vacuum Industries GmbH  
Leginglenstrasse 17A; CH-7320 Sargans  
Switzerland  
telephone +41 / 81 710 03 80  
telefax +41 / 81 710 03 81

## Scope of represented countries

Armenia, Azerbaijan, Bangladesh, Belarus, Bulgaria,  
Cambodia, Estonia, Georgia, Kazakhstan, Kingdom of Nepal,  
Kirghizia, Latvia, Lithuania, Maldives, Philippines, P.R. China,  
Rumania, Russia, Tajikistan, Turkmenistan, Ukraine,  
Uzbekistan, Vietnam

## A.E.M.S.

Advanced Equipment Materials and Systems  
P.O. Box 25  
Föhrenweg 18  
FL-9496 Balzers  
telephone +423 / 380 0550  
telefax +423 / 380 0551

## Scope of represented countries

Bahrain, Egypt, Iraq, Iran, Jordan, Kuwait, Lebanon, Lybia,  
Oman, Pakistan, Saudi-Arabia, Sudan, Syria, Turkey, United  
Arab Emirates, Yemen

## Zentrale/Headquarters

Pfeiffer Vacuum GmbH

Berliner Str. 43  
D-35614 Asslar

Telefon 06441/802-0  
Telefax 06441/802-202  
Hotline 06441/802-333  
www.pfeiffer-vacuum.de

**PFEIFFER**  **VACUUM**