

Turbomolecular Drag Pumps, With Magnetic Bearings



TMH 200M

TMU 200M

PM 800 574 BE/C (0204)

	Page		Page
1. Safety Instructions	3	4. Operations	9
1.1. For Your Orientation.....	3	4.1. Before Switching ON.....	9
1.2. Pictogram Definitions.....	3	4.2. Switching ON.....	9
2. Understanding The		Switching ON Where Large Backing Pumps	
TMH 200 M/ TMU 200M	4	And Large Vacuum Chambers Are Involved	9
2.1. Main Features.....	4	4.3. Heating (only for pumps with casing heating unit).....	9
2.2. Differences Between The Pump Types.....	4	4.4. Intermittent Mode Operations	
3. Installation	5	Of The Backing Pump	9
3.1. Preparations For Installation.....	5	4.5. Switching OFF And Venting.....	9
3.2. Installing The Pump, Connecting The		4.6. Safety Bearings.....	10
High Vacuum Side.....	5	4.7. Shutting Down For Longer Periods	10
Fitting The Splinter Shield.....	6	5. What To Do In Case	
3.3. Connecting The Fore-Vacuum Side	6	Of Breakdowns?	11
3.4. Connecting The Cooling Unit.....	6	6. Maintenance	12
Water Cooling	6	7. Service	12
Air Cooling (Accessory)	7	8. Technical Data	13
3.5. Connecting The Venting Valve	7	8.1. Dimensions.....	14
3.6. Connecting The Sealing Gas.....	8	9. Spare Parts	15
3.7. Connecting The Casing Heating Unit.....	8	10. Accessories	15
3.8. Connecting The Magnetic Bearing Controller	8	Declaration of Contamination	16
		Manufacturer's Declaration	last page

1. Safety Instructions

- ☞ Read and follow all instructions in this manual.
- ☞ Inform yourself regarding:
 - Hazards which can be caused by the pump;
 - Hazards which can be caused by your system.
 - Hazards which can be caused by the media being pumped.
- ☞ Avoid exposing any part of the body to vacuum.
- ☞ Observe the safety and accident prevention regulations.
- ☞ Regularly check that all accident prevention measures are being complied with.
- ☞ Do not operate the turbopump with open high vacuum flange.
- ☞ Do not carry out any unauthorised conversions or alterations to the turbopump.
- ☞ When returning the turbopump observe the shipping instructions.
- ☞ Use at least 4 bracket screws to connect the high vacuum flange.
- ☞ The turbopump must be anchored in accordance with the installation instructions.
- ☞ Do not disconnect the pump cable during operations.
- ☞ When the turbopump is open disconnect the voltage supply to the magnetic bearing.
- ☞ After switching off the turbopump only disconnect the magnetic bearing from the mains once the rotor is at rest.
- ☞ If a heater is in use temperatures of up to 120 °C can be present in the area of the high vacuum flange. Take care to avoid burns!
- ☞ During operations, temperatures of up to 65 °C can arise in the lower part of the turbopump. Take care to avoid burns!
- ☞ Keep leads and cables well away from hot surfaces (> 70 °C).
- ☞ When working on the turbopump, the high vacuum flange should only be opened once the rotor is at rest.
- ☞ When using sealing gas, the pressure in the hose connection should be limited to 2 bar via the overpressure valve.
- ☞ The unit has been accredited protection class IP 20. When the unit is operated in environments which require other protection classes, the necessary measures must be taken.

1.1. For Your Orientation

Instruction in the text

- ➔ Working instruction: Here, you have to do something.

Symbols used

The following symbols are used throughout in illustrations.

- Ⓜ High vacuum flange
- Ⓥ Fore-vacuum flange
- ⓕ Venting connection
- Ⓢ Cooling water connection
- Ⓣ Electric connection
- ⓐ Sealing gas connection

Abbreviations in the text

TCM = Magnetic bearing controller

TMP = Turbomolecular pump

Abbreviations on the type plate of the pump

TMH 200M: Fully magnetic bearing pump

Suffix "P": Purge gas connection for the prevention of the ingress of aggressive gases into the motor and bearing area

Position numbers

The same pump and accessory parts have the same position numbers in all illustrations.

1.2. Pictogram Definitions



Danger of burns from touching hot parts.



Danger of an electric shock.



Danger of personal injury.



Danger of damage to the pump or to the system.



Danger of injury from rotating parts.

Modifications reserved.

2. Understanding The TMH 200M / TMU 200M

2.1. Main Features

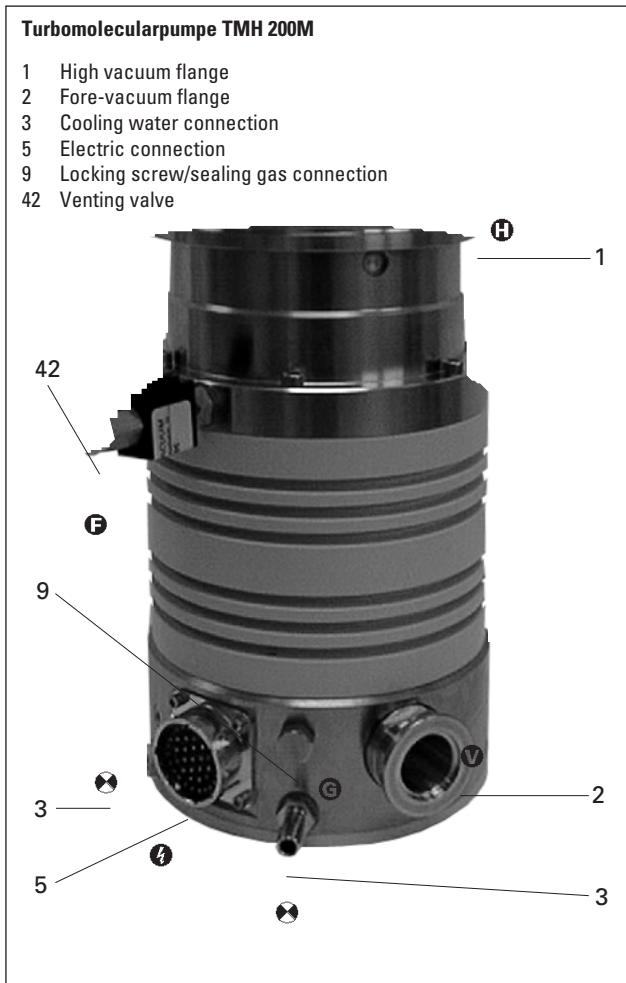

Cooling

Standard: Water cooling

Alternative: Air cooling as an accessory (permissible ambient temperature 0-30 °C).

Gas throughput and fore-vacuum pressure is reduced (see Section 8. "Technical Data").

Bearings

High vacuum side: Wear free permanent magnetic bearing.

Fore-vacuum side: Wear free, electromagnetic radial and axial bearings.

In addition: Dry running safety bearings.

Proper use

- The Turbomolecular Pumps TMH/TMU 200M may only be used for the purpose of generating vacuum.
- The turbopumps may only be used to pump those media against which they are chemically resistant. For other media the operator is required to qualify the pumps for the processes involved.
- If the process produces dust, the maintenance intervals must be specified accordingly and sealing gas must be used.
- The turbopump may only be operated in conjunction with a PFEIFFER Magnetic Bearing And Electronic Drive Unit TCM 1601 with relevant cables.
- The turbopump must be connected to a backing pump in accordance with Section 3.3.
- The turbopump may only be operated subject to the ambient conditions in accordance with protection class IP 20.

Improper use

The following is regarded, inter alia, as improper:

- The pumping of explosive gases.
- Operating the pumps in areas where there is a danger of explosion.
- The pumping of gases and vapours which attack the materials of the pumps.
- The pumping of corrosive gases without sealing gas.
- The pumping of condensating vapours.
- Operations involving impermissibly high levels of gas loads.
- Operations with improper gas modes.
- Operations involving too high levels of heat radiation power (see Section 8. "Technical Data").
- Operations with convection cooling.
- The use of accessories which are not named in this manual or which have not been agreed by the manufacturer.
- Operating the pump in environments which require a protection class superior to IP 20.

Improper use will cause all claims for liability and guarantees to be forfeited.

2.2. Differences Between The Pump Types

Feature	TMH 200M	TMU 200M
High vacuum flange	DN 100 ISO-K	DN 100 CF-F
Seal	Viton	Metal
Attainable final pressure	< 1 · 10 ⁻⁸ mbar (without baking-out)	< 5 · 10 ⁻¹⁰ mbar (with baking-out)

3. Installation

3.1. Preparations For Installation



Do not carry out any unauthorised conversions or alterations to the turbopump.

- The maximum permissible rotor temperature of the pump is 100 °C. If the vacuum chamber or parts in the vacuum chamber are heated, the values stated in the technical data relating to the level of heat which may be radiated into the pump must not be exceeded. If necessary, suitable shielding must be fitted in the vacuum chamber before the turbopump (constructional suggestions available on request).
- Only remove the blank flange from the high and for-vacuum side immediately before connection.
- Where magnetic fields of > 3 mT are involved suitable shielding must be provided (available on request).
- If the pump is baked out, the heating sleeve and the body of the pump must be heat insulated to prevent burns from accidental contact.
- In the event of a sudden standstill of the rotor, torques of up to 570 Nm can arise and these must be taken up by the turbopump and frame. Pumps must be anchored as follows:
 - ISO flange with 4 bracket screws, or
 - CF flange with the complete set of M8 screws, or
 - underside of the pump with 4 screws M6, screws quality 8.8.

3.2. Installing The Pump, Connecting The High Vacuum Side

Important

The utmost cleanliness must be observed when fitting all high vacuum parts. Unclean components prolong the pumping time.

Using the splinter shield

The use of a splinter shield (accessory) in the high vacuum flange protects the turbopump against foreign bodies coming from the vacuum chamber but does reduce the volume flow rate of the pump by approximately 15%.

For fitting splinter shields please refer to "Fitting the splinter shield"

The high vacuum side can be flanged directly to the vacuum chamber or via a bellows or a vibration compensator.

Connecting Via A Bellows

If the high vacuum side is to be flanged via a bellows, the turbopump must be secured for example via the holes on the underside of the turbopump must be secured for example via the holes on the underside of the pump. The fastening must be able to withstand the torque referred to in Section 3.1.

Connecting Via A Vibration Compensator



The maximum permissible temperature at the vibration compensator is 100°C.

When a vibration compensator is in use constructional advice from the manufacturer must be requested.

Directly Flanging The Pump

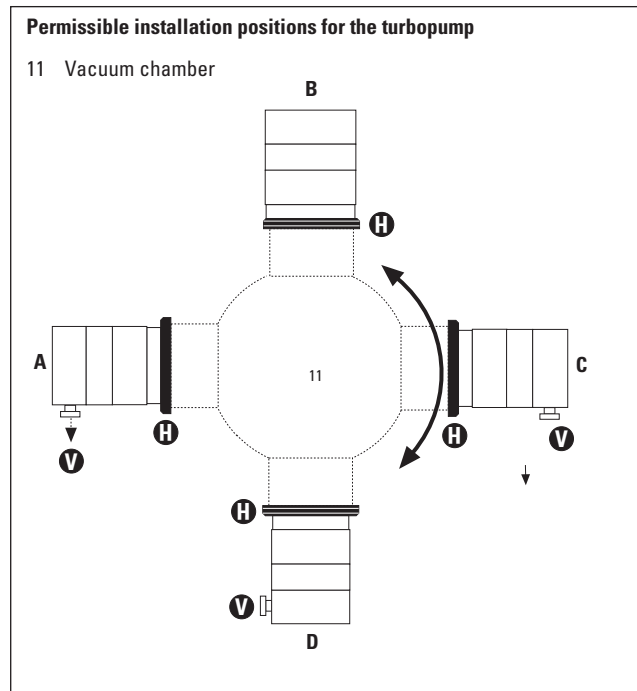

The maximum loading capacity of the high vacuum flange is 1000 N (equivalent to 100 kg). Asymmetric loading on the high vacuum flange must be avoided. Do not subject the pump to jolting.

Where rotary vane vacuum pump backing pumps with installation position A or C are involved the fore-vacuum flange must point downwards.

The use of rotary vane vacuum pumps is not recommended where installation position B has been selected.



No forces from the piping system must be allowed to act on the pump where turbopumps are anchored. Suspend or support all pipes to the pump.

Fitting The Splinter Shield

Insert the splinter shield in the high vacuum flange in such a way that the corrugation of the strainer points outwards.

- ➔ Bend the clamping lugs slightly outwards so that subsequently the splinter shield is seated firmly in the high vacuum flange (to avoid noise).
- ➔ Insert the splinter shield in the high vacuum flange while pressing the clamping lugs slightly inwards.
- ➔ Press the outer ring of the splinter shield up to the limit stop point in the high vacuum flange.

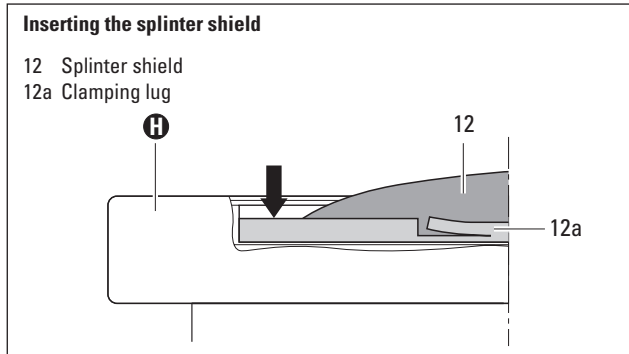

3.3. Connecting The Fore-Vacuum Side

Recommended PFEIFFER backing pump

- dry compressing:
Diaphragm Pump MVP 055-3
- for large vacuum chambers:
Rotary Vane Vacuum Pumps DUO 010 M; UNO 030 B

Connecting the backing pump

All connections of the fore-vacuum line: With the usual small flange components or hose screw connections.



Be sure to conduct away the exhaust gases from the backing pump. Do not reduce the free cross section of the fore-vacuum flange with following components.



The exhausted process gases and vapours can represent a health hazard and can also be environmentally damaging. Comply with all the gas manufacturer's safety instructions.

- ➔ Fit the delayed opening fore-vacuum safety valve (e.g. TVV 001, Accessory) in the fore-vacuum line (in PFEIFFER rotary vane vacuum pumps already integrated as standard). This prevents the vacuum chamber being ventilated via the backing pump.

- ➔ With rigid pipe connections: Fit a bellows in the connecting line to reduce vibration.

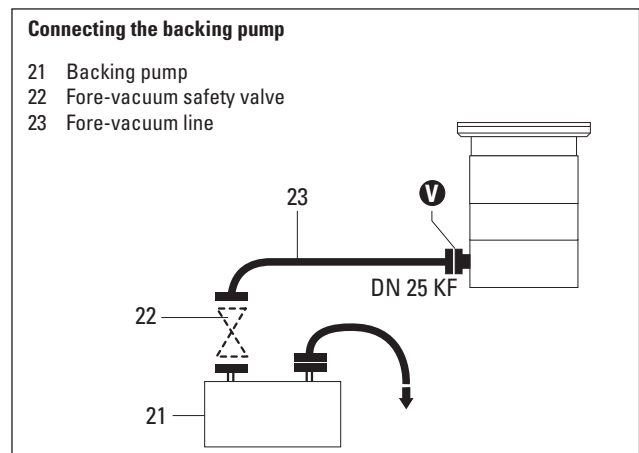

- ➔ The electrical connection of the backing pump: Please see the operating instructions for the Magnetic Bearing controller TCM 1600, PM 800 478 BN.

3.4. Connecting The Cooling Unit

The Turbopumps TMH/TMU 200M are water cooled as standard. The permissible ambient temperature for water cooling is 0 - 50 °C.

Where operations with reduced gas load are involved, air cooling is possible as an alternative (please see "Accessories")

The permissible ambient temperature with air cooling is 0-30 °C. The maximum gas throughput and fore-vacuum pressure reduces compared with water cooling (please refer to Section 8. Technical Data).

Water Cooling

The cooling water can be drawn either

- from the cooling water mains or
- from Recycled Water Cooling Unit TZK in closed circuit.

Cooling from the cooling water mains

To prevent deposits collecting in the pump the cooling water must be filtered.

The minimum requirements for the cooling water:

Mechanically clean, optically clear, no turbidity, no sediment, chemically neutral and temperature > dew point.

Oxygen content:	max. 4 mg/kg
Chloride content:	max. 100 mg/kg
Carbonate hardness:	max. 10 °dH
Consumption of potassium permanganate:	max. 10 mg/kg
Carbon dioxide:	Undetectable
Ammonia:	Undetectable
pH-value:	7 - 9
Max. fore-line over pressure:	max. 6 bar
Minimum flow rate:	see 8. "Technical Data"

Connection to the cooling water mains

- ➔ Fit the dirt trap (Accessory) in the supply line.
- ➔ Connect the supply line with hose clips onto one of the two cooling water connections.
- ➔ Connect the return line to the other cooling water connection of the turbopump.
- ➔ Tighten the cooling water connections to a torque of 10 Nm.
- ➔ Tighten all hose clips and check for firm seating of the hoses.

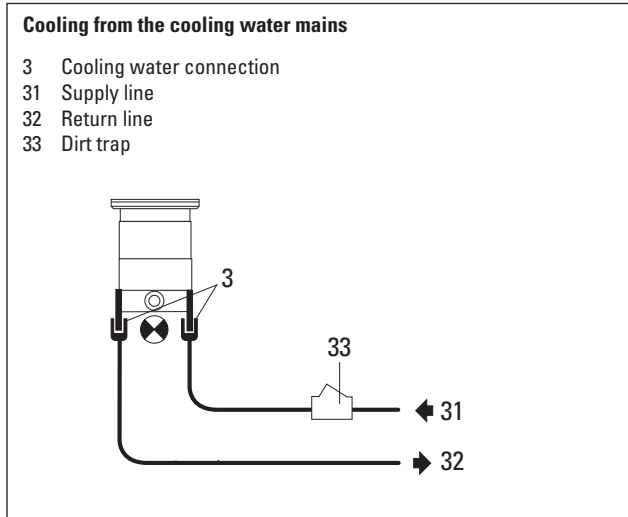

Cooling with the Recycled Water Cooling Unit TZK (Accessory)

Dirt traps in the fore-lines are not necessary.
All other steps as for connecting to the cooling water mains.

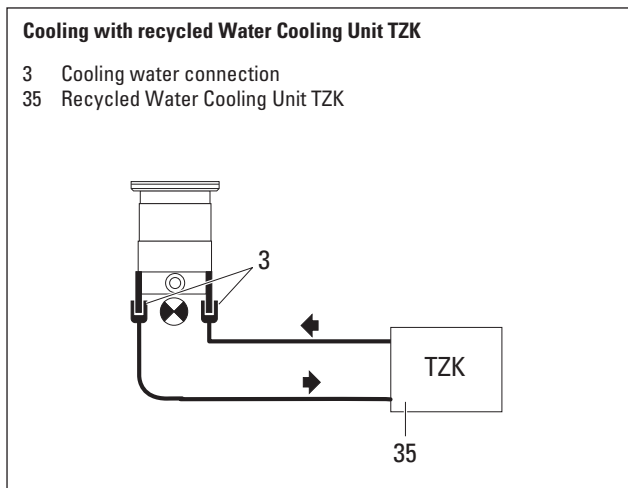

Air Cooling (Accessory)



Air cooling is only permissible where the ambient temperature is < 30 °C.
Ensure that the supply and exhaust air ducts are not restricted.
The maximum gas load with air cooling reduces (please refer to Section 8. Technical Data).

Fitting the air cooling unit

- ➔ Place a fluff-free and clean pad on the working surface.
- ➔ Place the pump on its high vacuum flange (Caution: do not damage the sealed surfaces).
- ➔ Unscrew the rubber feet on the base of the pump.
- ➔ Screw the air cooling unit with holder 37 with the rubber feet onto the turbopump.

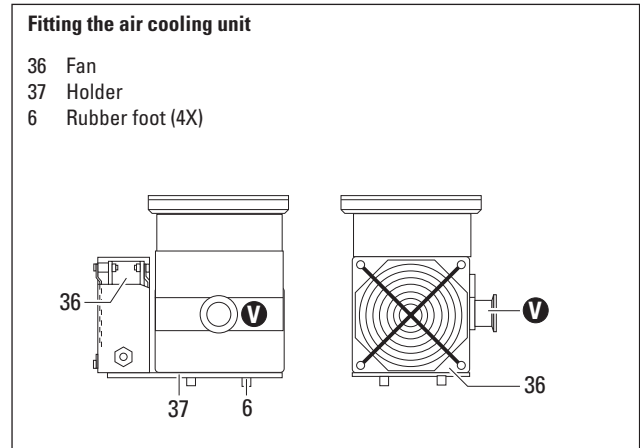

Electrical connection, air cooling

- ➔ The electrical connection of the air cooling unit is made on the control line 57 (please see Section 3.8.) on the connecting cable TCM-turbopump (see the operating instructions for the TCM 1601, PM 800 478 BN).

Alternatively the heating sleeve can be connected to the control line. Simultaneous operations of the functions is not possible.

3.5. Connecting The Venting Valve



The TMH/TMU 200M may only be vented via the venting valve which has already been fitted.
The use of other venting valves is not permitted.

The maximum pressure on the venting valve: 1.5 bar absolute.
If a higher venting rate is required further venting components can be opened as soon as the rotation speed of the pump is less than 100 Hz.
If, from the beginning, the pump is to be vented with equipment other than that fitted, the pressure increase on the high vacuum flange must be limited to 1 mbar/s until the rotation speed is less than 100 Hz.

Electrical connection, venting valve

The electrical connection of the venting valve is via the connecting cable magnetic bearing controller - turbopump.

- ➔ Connect the plug from the cable junction to the venting valve and secure with screw.

Please also refer to the connections diagram for the TCM 1601 in Operating Instructions PM 800 478 BN.

3.6. Connecting The Sealing Gas

To protect the pump, particularly where corrosive or dust producing processes are involved, it is necessary to use sealing gas. Connection is made via the sealing gas valve (please see "Accessories").

For this, please refer to Section 2.1. "Main Features" for the sealing gas connection.

Please refer to Operating Instructions PM 800 229 BN for details on installing the sealing gas valve and adjusting the sealing gas flow.

3.7. Connecting The Casing Heating Unit

Final pressures are attained more rapidly when turbopump and vacuum chamber are heated.

The heating duration is dependent on the degree of contamination and on the required final pressure. The heating should last for at least 4 hours.

Please note:

Where casing heating unit is involved the turbopump must be water cooled.



High temperatures arise when baking out turbopumps and vacuum chambers. There is a danger of burns from touching hot parts, even after the heating has been switched off.

Ideally, the heating sleeve, pump casing and vacuum chamber should be isolated during installation. When baking out do not touch the heating sleeve, pump casing and vacuum chamber.

- ➔ Screw the heating sleeve tightly onto the casing with the securing screws and fit protection against accidental contact.
- ➔ Electrical connection, heating unit: Please see Operating Instructions PM 800 478 BN for the TCM 1601.

3.8. Connecting The Magnetic Bearing Controller

- ➔ Plug in the connecting cable between the magnetic bearing controller and the turbopump.



Take care to ensure that the cable plugs are put straight onto the built-in plugs to avoid damage to the connection points.

For details please refer to the operating instructions for the Magnetic Bearing Controller

TCM 1601/PM 800 478 BN.

Connecting the magnetic bearing controller with the turbopump

- 50 Magnetic Bearing Controller TCM
- 51 Bayonet plug - TCM
- 52 Connecting cable TCM - TMP
- 53 Bayonet plug TMP
- 54 Venting Valve TVF 005
- 57 Control line

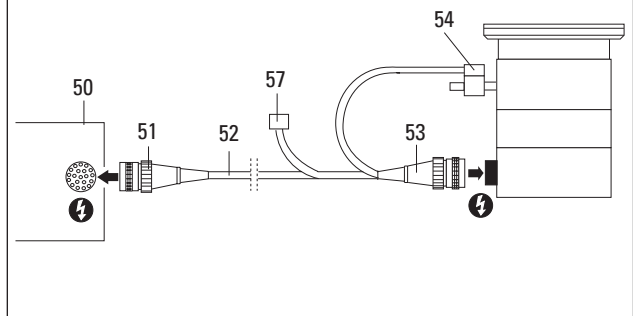

Before disconnecting the plug connection:

- Rotor rotation speed = 0 Hz
- Disconnect the magnetic bearing controller from the mains.



Voltages of up to 150 V can be present on the open contacts of a running-down pump.

There is a danger of an electrical shock from touching the contacts.

4. Operations

4.1. Before Switching ON



Turbopump rotors rotate at high speed. When the high vacuum flange is open there is a danger of injury and of damage to the pump caused by objects falling into the pump. Therefore never operate the pump with open high vacuum flange.



When operating with air cooling and heating high temperatures can arise on the pump surfaces.

- ➔ Pre-select the required operational functions and parameters on the Magnetic Bearing Controller TCM 1601.
- ➔ With water cooling: Open cooling water supply and check flow.

4.2. Switching ON

- ➔ Switch on the magnetic bearing electronic drive unit with switch S1 on the rear side of the TCM 1601.
- ➔ Switch on the drive and bearings with the push button  on the front panel of the TCM 1601.
 - If air cooling is involved the cooling fan is also switched on by the magnetic bearing electronic drive unit.
 - The backing pump is automatically started with the Pumping Station Control Unit TCS 180.
- ➔ Switch on the backing pump if it is not switched via the pumping station control unit.

Switching ON Where Large Backing Pumps And Large Vacuum Chambers Are Involved

A powerful flow air is generated in the TMP when evacuation begins. This can lead to instability in the magnetic bearing. In order to prevent this, a delay can be programmed in the TCM 1601 between switching on the backing pump and the start up of the magnetic bearing (please refer to Section "Switching On The Pump) in the TCM 1601 Operating Instructions PM 800 478 BN.



Take care when pumping hazardous gases and observe the safety precautions of the gas manufacturer.

4.3. Heating (only for pumps with casing heating unit)

The heating duration is dependent on the degree of contamination and on the required final pressure. The heating should last for at least 4 hours.

Please note:

Where casing heating unit is involved the turbopump must be water cooled.

- ➔ Switch on the turbopump heating in the menu of the magnetic bearing electronic drive unit (please see Operating Instructions PM 800 478 BN for the TCM 1601).

4.4. Intermittent Mode Operations Of The Backing Pump

Where Pumping Station Control Unit TCS 180 is in operation there is the option, under certain pre-conditions, to select intermittent mode operations on the diaphragm pump (please refer to the Section "Operations With Pumping Station Control Unit TCS 180 in the TCM 1601 Operating Instructions PM 800 478 BN).

If the setting procedure described there cannot be executed the guide values

<710: **BkP Poff**> = 50 W und

<711: **BkP Pon**> = 80 W

can be used for the switch on and switch off thresholds.

4.5. Switching OFF And Venting

When switching off and venting the turbopump please take account of the fact that various venting modes are available (please refer to the operating instructions for the TCM 1601, PM 800 478 BN).

- ➔ Switch off the turbopump with the push button  on the front panel of the TCM 1601.
- ➔ Close the fore-vacuum safety valve (if applicable). Where Pumping Station Control Unit TCS 180 is involved, the valve closes automatically.
- ➔ With water cooling: Shut off the water supply.
- ➔ Shut off the supply of sealing gas if operating with sealing gas.
- ➔ Do not switch off the TCM 1601 or disconnect from the mains until the rotation speed has reached 0 Hz.



When operating the pump with aggressive gases and their reactive products, the operation of the backing pump and the sealing gas function should be continued for at least 15 minutes in order to protect the bearings and the drive and to ensure the complete pumping out of this media.

4.5. Safety Bearings

Where heavy, external vibration or improper operating is involved, the rotor is supported by an additional, dry-running safety bearing; a clearly audible sound is produced when this happens. The various causes are evaluated as follows:

- Power failure; Display Warning F 007, only low level strain on the safety bearing and, with a new safety bearing set, possible 150 times.
- Uncontrolled venting or vibration; Malfunction Display E 089; medium level strain on the safety bearing, and, with a new safety bearing set, possible 50 times.
- Cable disconnected between the electronics and the pump; Malfunction Display E 082 high level strain on the safety bearing, and, with a new safety bearing set, possible 10 times.

If there is a mix of the events referred to above, the criteria for the actual wear of the safety bearing is the sum of the partial wear arising from the individual events.

Please get in touch with your local PFEIFFER Service when a safety bearing replacement is required.

4.6. Shutting Down For Longer Periods



Vacuum pumps are sometimes used to pump aggressive or hazardous gases. There is a danger of personal injury resulting from coming into contact with process gases. Before removing a turbopump from the system, first:

- Vent the turbopump with a neutral gas or dry air.
- Ensure that there is no residual process gas in the system nor in the supply lines.

If the turbopump is to be shut down for more than a year:

- ➔ Remove turbopump from the system.
- ➔ Close the high vacuum flange and evacuate the turbopump via the fore-vacuum flange.
- ➔ Vent turbopump via the venting connection with nitrogen or dry air.
- ➔ Close fore-vacuum connection by blank flanging.
- ➔ Place the pump vertically on its rubber feet.
- ➔ In rooms with moist or aggressive atmospheres, the turbopump must be air-sealed in a plastic bag together with a bag of dessicant, e.g. silicagel.

5. What To Do In Case Of Breakdowns ?

The Magnetic bearing Controller TCM 1601 contains an integrated malfunction diagnosis system (error code table). The malfunction messages are explained in operating instructions for the TCM 1601, PM 800 478 BN and their possible causes are listed.

Problem	Possible causes	Remedy
Pump doesn't start	<ul style="list-style-type: none"> • Power supply interrupted 	<ul style="list-style-type: none"> • Check fuse in the magnetic bearing controller • Check plug contacts on the magnetic bearing controller • Check supply line
Pump doesn't attain nominal rotation speed; Pump cuts out during operations	<ul style="list-style-type: none"> • Fore-vacuum pressure too high • Leak or too much gas • Start-up phase in the magnetic bearing controller set too short • Thermal overloading caused by <ul style="list-style-type: none"> – flow insufficient – air supply insufficient – fore-vacuum pressure too high – ambient temperature too high 	<ul style="list-style-type: none"> • Check backing pump function • Check seals • Seek leak and repair • Reduce gas load • Increase the start-up phase • Ensure free flow • Ensure adequate air supply • Reduce fore-vacuum pressure • Reduce ambient temperature
Pump doesn't attain final pressure	<ul style="list-style-type: none"> • Pump dirty • Leak in vacuum chamber, lines or pump 	<ul style="list-style-type: none"> • Bake out pump • If seriously contaminated: Request PFEIFFER Service to clean • Seek leak starting with vacuum chamber • Repair leak
Unusual operating noises	<ul style="list-style-type: none"> • Rotor damaged • Splinter shield (if fitted) not seated firmly • Pump runs in the safety bearings 	<ul style="list-style-type: none"> • Inform PFEIFFER Service of need for repair • Check seat of splinter shield (see Section 3.2.) • Remove the cause; start the pump again

6. Maintenance

Important

No liability for personal injury nor material damage will be accepted for damages and operational interruptions which have been caused by improper maintenance; in addition, all guarantees become invalid.

Your pump can be cleaned on the spot if it is not very dirty. Please check procedures with your local PFEIFFER Service Center.

Your local PFEIFFER Service can advise you regarding cleaning procedures and any other maintenance and service work.

7. Service

Do Make Use Of Our Service Facilities

In the event that repairs are necessary a number of options are available to you to ensure any system down time is kept to a minimum:

- Have the pump repaired on the spot by our PFEIFFER Service Engineers;
- Return the pump to the manufacturer for repairs;
- Replace the pump.

Local PFEIFFER representatives can provide full details.

Before Returning:

- ➔ Please attach a clearly visible notice "Free of harmful substances" (both on the unit and also on the delivery note and any accompanying letters).

"Harmful substances" are substances and preparations as defined in the current, local, dangerous substances regulations; in the U.S.A. as "materials in accordance with the Code of Federal Regulations (CFR) 49 Part 173.240 Definition and Preparation".

We will carry out the decontamination and invoice this work to you if you have not attached this note. This also applies where the operator does not have the facilities to carry out the decontamination work. Units which are contaminated microbiologically, explosively or radioactively cannot be accepted as a matter of principle.

Fill Out The Declaration Of Contamination

- ➔ In every case the "Declaration of Contamination" must be completed diligently and truthfully.
- ➔ A copy of the completed declaration must accompany the unit; any additional copies must be sent to your local PFEIFFER Service Center.

Please get in touch with your local PFEIFFER representatives if there are any questions regarding contamination.



Decontaminate units before returning or possible disposal. Do not return any units which are microbiologically, explosively or radioactively contaminated.

Returning Contaminated Units

If contaminated have to be returned for maintenance/repair, the following instructions concerning shipping must be followed:

- ➔ Neutralise the pump by flushing with nitrogen or dry air.
- ➔ Seal all openings to the air.
- ➔ Seal pump or unit in suitable protective foil.
- ➔ Ship units only in appropriate transport containers

Please Note:

Repair orders are carried out according to our general conditions of sale and supply. If repairs are necessary, please send the pump to your nearest PFEIFFER Service Center.

Contact Addresses And Telephone Hotline

Contact addresses and telephone numbers can be found on the back cover of these operating instructions.

8. Technical Data

Feature	Unit	TMH 200M	TMU 200M
Connection nominal diameter: Inlet Outlet		DN 100 ISO-K DN 25 ISO-KF	DN 100 CF-F
Magnetic bearing controller		TCM 1601	
Nominal rotation speed	1/min	50 000	
Standby rotation speed	1/min	33 000	
Start-up time (up to 90% of the nominal rotation speed with TCM 1601)	min	1.5	
Noise level	dB (A)	< 40	
Maximum permissible rotor temperature	°C	100	
Permissible heat radiation power	W	23	
Volume flow rate (with oil-sealed rotary vane vacuum pump) for:			
Nitrogen N ₂	l/s	180	
Helium He	l/s	150	
Hydrogen H ₂	l/s	105	
Compression ratio for:			
N ₂	–	> 10 ¹⁰	
He	–	3 · 10 ⁷	
H ₂	–	5 · 10 ⁵	
Critical backing pressure, max.			
N ₂ Cooling type: water	mbar	12	
air	mbar	7	
Gas throughput, max.			
N ₂ Cooling type: water	mbar l/s	10	
air	mbar l/s	2	
Ar Cooling type: water	mbar l/s	6	
air	mbar l/s	1	
Theoretical final pressure	mbar	< 10 ⁻¹¹	
Final pressure 1 (metal seal with baking out)	mbar	5 · 10 ⁻¹⁰	
Final pressure 2 (viton seal without baking out)	mbar	1 · 10 ⁻⁸	
Cooling water consumption with water at 15 °C	l/h	120	
Cooling water temperature	°C	5 - 25	
Permissible ambient temperature with water cooling	°C	0 - 50	
air cooling	°C	0 - 30	
Power consumption of: casing heating unit	W	100	
Permissible magnetic field	mT	3	
Protection Class		IP 20	
Weight	kg	11.4	
Relative humidity	%	5 - 85 non-condensing	

8.1. Dimensions

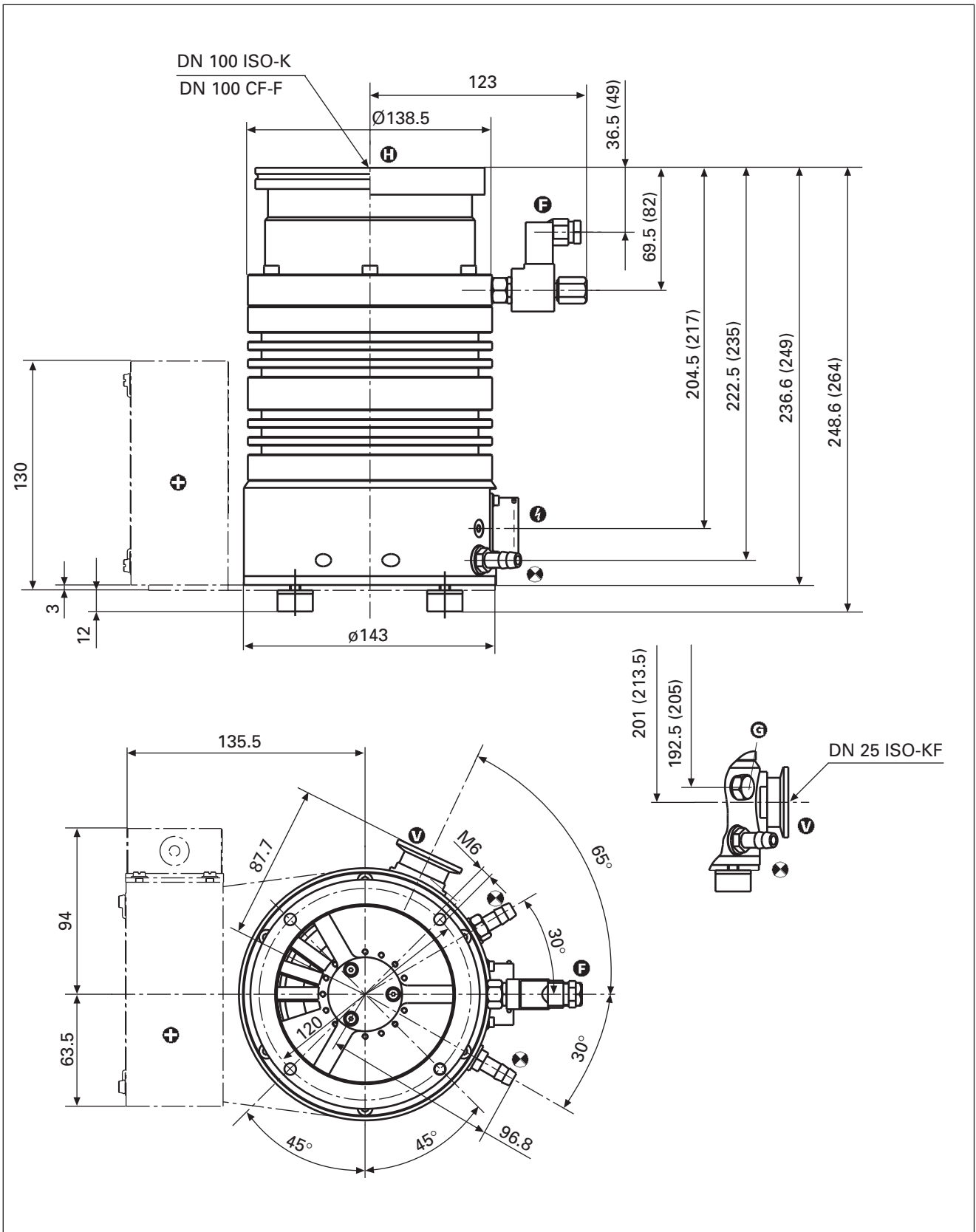

Values in brackets be for TMU 200M (DN 100 CF-F).

9. Spare Parts

Pos.	Description	Pieces	Size	Number	Comments	Ordering Quantity
Spare parts TMH/U 200M						
6	Rubber foot	4		PK 001 111		
16	USIT ring	2	U 10,35x16x2	P 3529 133 -A		
54	Venting Valve TVF 005	1	G 1/8"	PM Z01 135	(see Section 2.1.)	
Spare parts for the air cooling unit						
36	Fan	1	110 V	P 5099 251 -R7		
36a	Finger protection	2		P 5099 251 Z4		
36b	Buffer	4		P 0991 099		

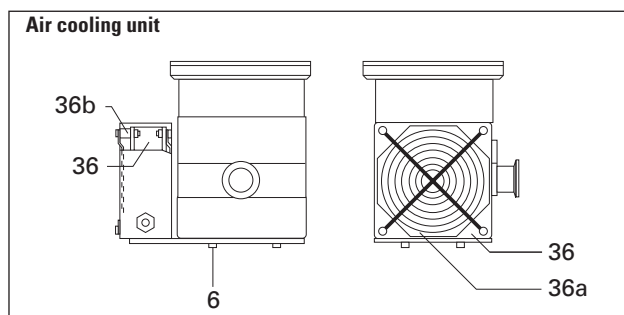
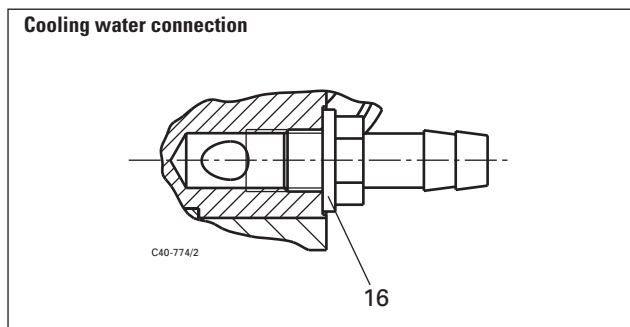

10. Accessories

Description	Size	Number	Operating Instructions/ Comments	Order Quantity
Magnetic Bearing Controller TCM 1601	90 - 132 V; 50/60 Hz 110 - 265 V; 50/60 Hz	PM C01 675	PM 800 478 BN	
Connecting cable turbopump - TCM	3 m	PM 051 003 -T	other lengths on request	
Pumping Station Control Unit TCS 180	90-122 V, 50/60 Hz 195-265 V, 50/60 Hz	PM C01 655	PM 800 384 BN	
Casing heating unit	230 V AC, Schuko 208 V AC, UL-Stecker 115 V AC, UL-Stecker	PM 041 903 -T PM 041 904 -T PM 041 905 -T	Water cooling required	
Splinter shield	DN 100	PM 006 125 AX		
Protective grill	DN 100	PM 006 596 -R		
PWM adapter box		PM 051 028 -U	PM 800 563 BN	
Battery Box TBB 001		PM K01 712	PM 800 588 BN	
Level Converter RS 232/485		PM 051 054 -T	PM 800 549 BN	
Sealing ring, TMH	DN 100 ISO-K	PF 303 110 -T		
Collar flange with retaining ring, TMH	DN 100 ISO-K	PF 307 110 -T		
Cu seals (10 pieces), TMU	DN 100 CF	PF 501 410 -T		
Set of screws, TMU	DN 100 CF	PF 505 003 -T		
	DN 160 CF	PF 505 003 -T		
Vibration compensator, TMH	DN 100 ISO-K	PM 006 459 -X		
	DN 160 ISO-K	PM 006 492 -X		
	DN 100 CF	PM 006 488 -X		
	DN 160 CF	PM 006 493 -X		
Fore-Vacuum Safety Valve TVV 001	115 V 230 V	PM Z01 206 PM Z01 205	PM 800 263 BN only with TCS 180	
Drying Unit TTV 001 (filled with zeolite)		PM Z00 121	PM 800 022 BN	
Sealing gas valve		PM Z01 142	PM 800 229 BN	
Hose nipple for the sealing gas valve	DN 16 ISO-KF-10	PF 144 020		
Components for cooling				
Dirt trap	R 3/8"	P 4161 300 2R		
Recycled Water Copoling unit TZK 400	230 V, 50 Hz	PM Z01 245	PM 800 369 BN	
Set for air cooling	230/208 V 115 V	PM Z01 280 PM Z01 282		

When ordering accessories and spare parts please be sure to state the full part number. When ordering spare parts please state additionally the unit type and unit number (see rating plate). Please use this list as an order form (by taking a copy).

Declaration of Contamination of Vacuum Equipment and Components

The repair and/or service of vacuum components will only be carried out if a correctly completed declaration has been submitted. Non-completion will result in delay.

The manufacturer could refuse to accept any equipment without a declaration.

This declaration can only be completed and signed by authorised and qualified staff:

1. Description of component:

- Equipment type/model: _____
- Code No.: _____
- Serial No.: _____
- Invoice No.: _____
- Delivery Date: _____

2. Reason for return:

3. Equipment condition

- Has the equipment been used?
yes no
- What type of pump oil was used?

- Is the equipment free from potentially harmful substances?
yes (go to section 5)
no (go to section 4)

4. Process related contamination of equipment

- toxic yes no
- corrosive yes no
- microbiological hazard*) yes no
- explosive*) yes no
- radioactive*) yes no
- other harmful substances yes no

*) We will not accept delivery of any equipment that has been radioactively or microbiologically contaminated without written evidence of decontamination!

Please list all substances, gases and by-products which may have come into contact with the equipment:

Tradename Product name Manufacturer	Chemical name (or Symbol)	Danger class	Precautions associated with substance	Action if spillage or human contact
1.				
2.				
3.				
4.				
5.				

5. Legally Binding Declaration

I hereby declare that the information supplied on this form is complete and accurate. The despatch of equipment will be in accordance with the appropriate regulations covering Packaging, Transportation and Labelling of Dangerous Substances.

Name of Organisation: _____

Address: _____ Post code: _____

Tel.: _____

Fax: _____ Telex: _____

Name: _____

Job title: _____

Date: _____ Company stamp: _____

Legally binding signature: _____

Herstellereklärung Manufacturer's Declaration

im Sinne folgender EU-Richtlinien:
pursuant to the following EU directives:

- **Maschinen/Machinery 98/37/EG**
- **Elektromagnetische Verträglichkeit/Electromagnetic Compatibility 89/336/EWG**
- **Niederspannung/Low Voltage 73/23/EWG**

Hiermit erklären wir, daß das unten aufgeführte Produkt zum Einbau in eine Maschine bestimmt ist und daß deren Inbetriebnahme so lange untersagt ist, bis festgestellt wurde, daß das Endprodukt den Bestimmungen der EU-Richtlinie 98/37/EG, Anhang II B entspricht.

Wir bestätigen Konformität mit der EU-Richtlinie über elektromagnetische Verträglichkeit 89/336/EWG und der EU-Niederspannungsrichtlinie 73/23/EWG.

We hereby certify that the product specified below is intended for installation in a machine which is forbidden to be put into operation until such time as it has been determined that the end product is in accordance with the provision of EU Directive 98/37/EEC, Annex II B.

We certify conformity with EU Electromagnetic Compatibility Directive 89/336/EEC and EU Low Voltage Directive 73/23/EEC.

Produkt/Product:

TMH 200M, TMU 200M

Angewendete Richtlinien, harmonisierte Normen und angewendete, nationale Normen:

Guidelines, harmonised standards, national standards in which have been applied:

**EN 292-1
EN 292-2**

**EN 294
EN 61 010-1**

EN 1012-2

Unterschrift/Signature:



Pfeiffer-Vacuum GmbH
Emmeliusstrasse 33
35614 Asslar
Germany

(W. Dondorf)
Geschäftsführer
Managing Director

Herst.l./2000

Adressen • Addresses

Argentina

ARO S.A., Av. Belgrano 369,
1092 Buenos Aires, telephone +54 / 11 4331 5766,
telefax +54 / 11 4331 3572

Australia

Sciteck Australia Pty. Ltd., Suite 1B,
10-18 Cliff Street, Milsons Point, NSW 2061,
telephone +61 / 2 9954 1925, telefax +61 / 2 9954 1939

Austria

Pfeiffer Vacuum Austria GmbH
Diefenbachgasse 35, A-1150 Wien,
telephone +43 / 1 8941 704, telefax +43 / 1 8941 707
Service Hotline: +43 / 1 8941704

Branch Office, Czech Republic

Pfeiffer Vacuum Austria GmbH, Branch Prague
Zvonarska 885
CZ-156 00 Praha 5
telephone +420/2 900 42981, telefax +420/2 579 23014

Belgium / Luxemburg

Pfeiffer Vacuum Belgium N.V./S.A.
Luxemburgstraat 5, B-9140 Temse
telephone +32 / 3 710 5920, telefax +32 / 3 710 5929
Service Hotline: +32 / 3 710 5922

Brazil

Elmi Tec
Assistencia Técnica e Representação S/C Ltda.
Rua Bernadino de Compos, 551-Brooklin
CEP 04620-002 São Paulo, SP - Brasil
telephone +55 / 11 5532 0740, telefax +55 / 11 5535 3598

Chile

BERMAT S.A., Coyancura 2283, Oficina 601
Providencia, P.O. Box 9781, Santiago
telephone +56 / 2 231 8877, telefax +56 / 2 231 4294

Colombia

Arotec Colombiana S.A., Carrera 16 No. 36-89
P.O. Box 050 862, Santafe de Bogota / D.C.
telephone +57 / 1 288 7799, telefax +57 / 1 285 3604

Denmark

Pfeiffer Vacuum Scandinavia AB, Vesterengen 2,
DK-2630 Taastrup,
telephone +45 / 43 52 38 00, telefax +45 / 43 52 38 50

France

Pfeiffer Vacuum France SAS
45, rue Senouque, BP 139
F-78531 BUC Cedex
telephone +33 / (0)1 30 83 04 00,
telefax +33 / (0)1 30 83 04 04

Germany

Pfeiffer Vacuum GmbH,
Berliner Strasse 43, D-35614 Asslar
telephone +49 / 6441 802 400, telefax +49 / 6441 802 399
Service Hotline: +49 / 6441 802 333

Great Britain

Pfeiffer Vacuum Ltd.
2-4 Cromwell Business Centre
Howard Way, Interchange Park
Newport Pagnell, MK16 9QS, United Kingdom
telephone +44 / 1 908 500615, telefax +44 / 1 908 500616

Greece

Analytical Instruments S.A., 1 Mantzarou St.,
GR-15451 Athens,
telephone +30 / 10 674 8973-7, telefax +30 / 10 674 8978

Hong Kong

Pfeiffer Vacuum Asia Ltd.
Units 06-07, 17/F, Workingfield Commercial Building,
408-412 Jaffe Road, Hong Kong
telephone +852 2575 6688, telefax +852 2575 6993

India

Pfeiffer Vacuum India Ltd.
25-E Nicholson Road, Tarbunda
Secunderabad 500 009,
telephone +91 / 40 775 0014, telefax +91 / 40 775 7774

Israel

ODEM Scientific Applications Ltd.
9 Hamazmera St., P.O.B. 2001 Nes Ziona
telephone +972 8 938 0333, telefax +972 8 938 0334

Italy

Pfeiffer Vacuum Italia S.p.a.
Via San Martino, 44 I-20017 RHO (Milano)
telephone +39 / 2 93 99 051, telefax +39 / 2 93 99 05 33

Japan

Hakuto Co. Ltd., C.P.O. Box 25,
Vacuum Scientific Instruments Division
C.P.O. Box 25, Tokyo 100-91
telephone +81 / 3 32 258 910, telefax +81 / 3 32 259 011

Korea

Pfeiffer Vacuum Korea Ltd.,
703 Ho, 853-1, Hankuk Mulru, Dongchonri, Suzi-Eup,
449-843 Yong-in City, Kyungkido
telephone +82 / 31 266 0741, telefax +82 / 31 266 0747

Netherlands

Pfeiffer Vacuum Nederland BV
Veldzigt 30a, NL-3454 PV De Meern,
telephone +31 / 30 6666050, telefax +31 / 30 6662794

Peru

Ing. E. Brammertz s.r.l., José Pardo 182,
Apartado 173, PE-18 Miraflores,
telephone +51 / 1 445 8178, telefax +51 / 1 445-1931

Poland

Softrade Sp.z.o.o, ul. Grunwaldzka 391,
PL-60-173 Poznan, telephone +48 / 61 8677 168,
telefax +48 / 61 8677 111

Portugal

Unilaser Lda, Taguspark
Núcleo Central, sala no 268, Estrada Cacém-
Porto Salvo, P-2780 Oeiras
telephone +351 / 1 421 7733, telefax +351 / 1 421 7744

Singapore

APP Systems Services Pte. Ltd, 2 Corporation Road
06-14 Corporation Place, Singapore 618494,
telephone +65 / 268 2024, telefax +65 / 268 6621

Spain

Tecnovac
Tecnologia de Vacío S.L.,
Sector Literatos, 38 - Local 1
ES-28760 Tres Cantos (Madrid)
telephone +34 / 91 804 11 34, telefax +34 / 91 804 30 91

Sweden

Pfeiffer Vacuum Scandinavia AB
Johanneslundsvägen 3
SE-194 61 Upplands Väsby
telephone +46 / 8 590 748 10, telefax +46 / 8 590 748 88

Switzerland

Pfeiffer Vacuum Schweiz S.A.
Förribuckstraße 30, CH-8005 Zürich
telephone +41 / 1 444 2255, telefax +41 / 1 444 2266

South Africa

Labotec Pty Ltd., P.O. Box 6553,
Halfway House
1685 Midrand
telephone +27 / 11 315 5434, telefax +27 / 11 315 5882

Taiwan

HAKUTO Taiwan Ltd. Hsinchu office No. 103,
Hsien Chen 11th Street, Chupei,
HsinChu County, Taiwan, R.O.C.
(zip/postal code: 302)
telephone +886 / 3 554 1020, telefax +886 / 3 554 0867

Thailand

Hakuto (Thailand) Ltd.
18th Floor, Chokchai Int'l Bldg.
690 Sukhumvit Road
Klongton, Klongtoey
Bangkok 10110
telephone +662 / 259 6244, telefax +662 / 259 6243

U.S.A.

Pfeiffer Vacuum, Inc.
24 Trafalgar Square
Nashua, NH 03063-1988
USA
telephone +1 / 603 578 6500, telefax +1 / 603 578 6550

Venezuela

Secotec S.A., Apartado 3452, Caracas 1010-A,
telephone +58 / 212 573 8687, telefax +58 / 212 573 1932

Other countries

AVI - Applied Vacuum Industries GmbH
Leginglenstrasse 17A; CH-7320 Sargans
Switzerland
telephone +41 / 81 710 03 80
telefax +41 / 81 710 03 81

Scope of represented countries

Armenia, Azerbaijan, Bangladesh, Belarus, Bulgaria,
Cambodia, Estonia, Georgia, Kazakhstan, Kingdom of Nepal,
Kirghizia, Latvia, Lithuania, Maldavia, Philippines, P.R. China,
Rumania, Russia, Tajikistan, Turkmenistan, Ukraine,
Uzbekistan, Vietnam

A.E.M.S.

Advanced Equipment Materials and Systems
P.O. Box 25
Föhrenweg 18
FL-9496 Balzers
telephone +423 / 380 0550
telefax +423 / 380 0551

Scope of represented countries

Bahrain, Egypt, Iraq, Iran, Jordan, Kuwait, Lebanon, Lybia,
Oman, Pakistan, Saudi-Arabia, Sudan, Syria, Turkey, United
Arab Emirates, Yemen

Zentrale/Headquarters

Pfeiffer Vacuum GmbH

Berliner Str. 43
D-35614 Asslar

Telefon 06441/802-0
Telefax 06441/802-202
Hotline 06441/802-333
www.pfeiffer-vacuum.de

PFEIFFER  **VACUUM**