

***Operating Instructions***

***TMH 1600M / TMU 1600M***

---

***Turbomolecular Drag Pumps.  
With Magnetic Bearings***



	Page		Page
<b>1. Safety Instructions</b> .....	<b>3</b>	<b>4. Operations</b> .....	<b>9</b>
1.1. For Your Orientation.....	3	4.1. Before Switching ON.....	9
1.2. Pictogram Definitions.....	3	4.2. Switching ON.....	9
<b>2. Understanding The TMH 1600 M/ TMU 1600M</b> .....	<b>4</b>	4.3. Heating (only for pumps with casing heating unit).....	9
2.1. Main Features.....	4	4.4. Operations With The TMS.....	10
2.2. Differences Between The Pump Types.....	4	4.5. Intermittent Mode Operations Of The Backing Pump.....	10
2.3. Temperature Management System (TMS).....	4	4.6. Gas Type Dependent Operations.....	10
<b>3. Installation</b> .....	<b>5</b>	4.7. Safety Bearings.....	11
3.1. Preparations For Installation.....	5	4.8. Switching OFF And Venting.....	11
3.2. Installing The Pump, Connecting The High Vacuum Side.....	5	4.9. Shutting Down For Longer Periods.....	11
Fitting The Splinter Shield (Accessory).....	6	<b>5. What To Do In Case Of Breakdowns?</b> .....	<b>12</b>
3.3. Connecting The Fore-Vacuum Side.....	6	<b>6. Maintenance</b> .....	<b>13</b>
3.4. Connecting The Cooling Unit.....	6	<b>7. Service</b> .....	<b>13</b>
Water Cooling.....	6	<b>8. Technical Data</b> .....	<b>14</b>
Air Cooling (Accessory).....	7	8.1. Dimensions.....	15
3.5. Connecting The Venting Valve.....	7	<b>9. Spare Parts</b> .....	<b>16</b>
3.6. Connecting The Sealing Gas.....	8	<b>10. Accessories</b> .....	<b>17</b>
3.7. Connecting The Casing Heating Unit.....	8	Declaration of Contamination.....	18
3.8. Connecting The Magnetic Bearing Controller.....	8	<b>Manufacturer's Declaration</b> .....	<b>last page</b>
3.9. Connecting The Temperature Management System (TMS).....	9		

**Please note:** Current operating instructions are available via [www.pfeiffer-vacuum.de](http://www.pfeiffer-vacuum.de) under "Infoservice".

# 1. Safety Instructions

- ☞ Read and follow all instructions in this manual.
- ☞ Inform yourself regarding:
  - Hazards which can be caused by the pump;
  - Hazards which can be caused by your system.
  - Hazards which can be caused by the media being pumped.
- ☞ Avoid exposing any part of the body to vacuum.
- ☞ Observe the safety and accident prevention regulations.
- ☞ Regularly check that all accident prevention measures are being complied with.
- ☞ Do not operate the turbopump with open high vacuum flange.
- ☞ Do not carry out any unauthorised conversions or alterations to the turbopump.
- ☞ When returning the turbopump observe the shipping instructions.
- ☞ Use at least 6 bracket screws to connect the high vacuum flange.
- ☞ The turbopump must be anchored in accordance with the installation instructions.
- ☞ Do not disconnect the pump cable during operations.
- ☞ When the turbopump is open disconnect the voltage supply to the magnetic bearing.
- ☞ After switching off the turbopump only disconnect the magnetic bearing from the mains once the rotor is at rest.
- ☞ If a heater is in use temperatures of up to 120 °C can be present in the area of the high vacuum flange. Take care to avoid burns!
- ☞ When the temperature management system is in operation, surface temperatures of up to 100 °C can arise on the middle and upper part of the pump. Because even higher temperatures are possible as a result of malfunctions, it is advisable to take protective measures against accidental touching for temperatures of up to 150 °C.
- ☞ Keep leads and cables well away from hot surfaces (> 70 °C).
- ☞ When working on the turbopump, the high vacuum flange should only be opened once the rotor is at rest.
- ☞ When using sealing gas, the pressure in the hose connection should be limited to 2 bar via the overpressure valve.
- ☞ The unit has been accredited protection class IP 20. When the unit is operated in environments which require other protection classes, the necessary measures must be taken.

## 1.1. For Your Orientation

### Instruction in the text

➔ Working instruction: Here, you have to do something.

### Symbols used

The following symbols are used throughout in illustrations.

- ⊕ High vacuum flange
- ⊖ Fore-vacuum flange
- ⊙ Venting connection
- ⊗ Cooling water connection
- ⚡ Electric connection
- ⊙ Sealing gas connection
- ⊕ Air cooling

### Abbreviations in the text

TMS = Temperature management system

TCM = Magnetic bearing controller

TMP = Turbomolecular pump

### Abbreviations on the type plate of the pump

TMH 1600M: Fully magnetic bearing pump

Suffix "C": Surface protection for passive protection of the pump

Suffix "P": Purge gas connection for the prevention of the ingress of aggressive gases into the motor and bearing area

Suffix "T": Integrated temperature management system

Suffix "H": High level gas throughputs for process technology

### Position numbers

The same pump and accessory parts have the same position numbers in all illustrations.

## 1.2. Pictogram Definitions



Danger of burns from touching hot parts.



Danger of an electric shock.



Danger of personal injury.



Danger of damage to the pump or to the system.



Danger of injury from rotating parts.



Attention to particularly important information on the product, handling the product or to a particular part of the documentation.

Modifications reserved.

## 2. Understanding The TMH 1600M / TMU 1600M

### 2.1. Main Features

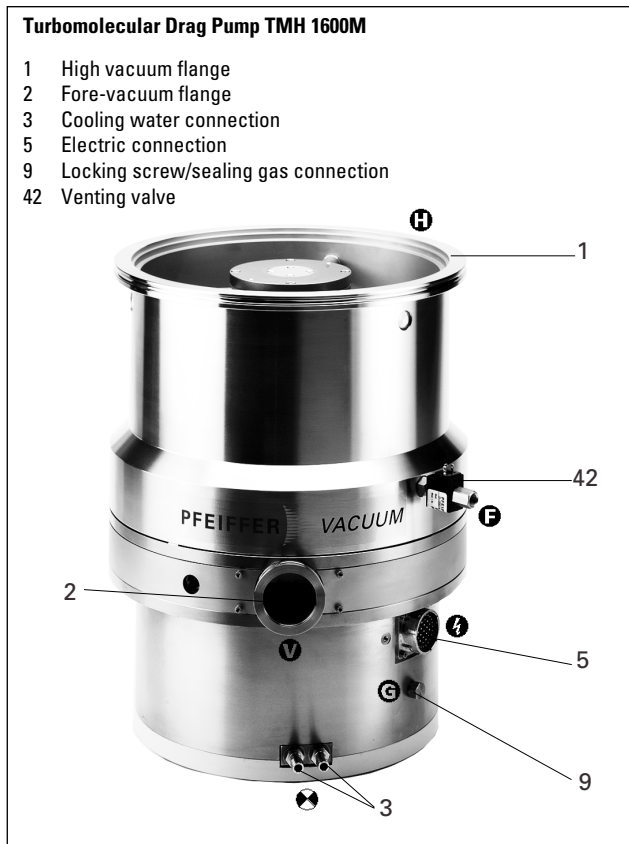

#### Cooling

Standard: Water cooling

Alternative: Air cooling as an accessory (permissible ambient temperature < 30 °C).

#### Bearings

High vacuum side: Wear free permanent magnetic bearing.

Fore-vacuum side: Wear free, electromagnetic radial and axial bearings.

In addition: Dry running safety bearings.

#### Proper use

- The Turbomolecular Pumps TMH/TMU 1600M may only be used for the purpose of generating vacuum.
- The Turbomolecular Pumps TMH/TMU 1600M C (please see the rating plate) are designed to pump corrosive gases and vapours. Where corrosive gas processes are involved, gas bonding and particles which can damage the surfaces of the pump can be produced. The motor and bearing compartments have to be protected with sealing gas.
- The turbopumps may only be used to pump those media against which they are chemically resistant. For other media the operator is required to qualify the pumps for the processes involved.

- If the process produces dust, the maintenance intervals must be specified accordingly and sealing gas must be used.
- The turbopump may only be operated in conjunction with a PFEIFFER Magnetic Bearing Controller TCM 1601 with relevant cables.
- The turbopump must be connected to a backing pump in accordance with Section 3.3.
- The turbopump may only be operated subject to the ambient conditions in accordance with protection class IP 20.

#### Improper use

The following is regarded, inter alia, as improper:

- The pumping of explosive gases.
- Operating the pumps in areas where there is a danger of explosion.
- The pumping of gases and vapours which attack the materials of the pumps.
- The pumping of corrosive gases without sealing gas.
- The pumping of condensating vapours.
- Operations involving impermissibly high levels of gas loads.
- Operations with improper gas modes.
- Operations involving too high levels of heat radiation power (see Section 8. "Technical Data").
- The use of accessories which are not named in this manual or which have not been agreed by the manufacturer.
- Operating the pump in environments which require a protection class superior to IP 20.

Improper use will cause all claims for liability and guarantees to be forfeited.

### 2.2. Differences Between The Pump Types

Feature	TMH 1600M	TMU 1600M	TMH 1600M H
High vacuum flange	DN 200 ISO-K DN 250 ISO-K	DN 200 CF-F DN 250 CF-F	DN 200 ISO-K DN 250 ISO-K
Seal	Viton	Metal	Viton
Attainable final pressure	< 1 · 10 <sup>-8</sup> mbar (without baking-out)	< 1 · 10 <sup>-10</sup> mbar (with baking-out)	< 5 · 10 <sup>-8</sup> (without baking-out)

### 2.3. Temperature Management System (TMS)

Pumps with the designation TMH 1600M T/TMU 1600M T (please see the rating plate) can be heated in the area of the pressure stages with the heaters integrated in the casing and temperature sensors up to a maximum of 90 °C.

The connections for heating and sensors are accessible centrally via a separate connection box.

When the TMS is in operation the additional casing heating unit on the turbomolecular pump is not possible.

## 3. Installation

### 3.1. Preparations For Installation



Do not carry out any unauthorised conversions or alterations to the turbopump.

- The maximum permissible rotor temperature of the pump is 120 °C. If the vacuum chamber or parts in the vacuum chamber are heated, the values stated in the technical data relating to the level of heat which may be radiated into the pump must not be exceeded. If necessary, suitable shielding must be fitted in the vacuum chamber before the turbopump (constructional suggestions available on request).
- Only remove the blank flange from the high and for-vacuum side immediately before connection.
- Where magnetic fields of > 4 mT are involved suitable shielding must be provided (available on request).
- If the pump is baked out, the heating sleeve and the body of the pump must be heat insulated to prevent burns from accidental contact.
- In the event of a sudden standstill of the rotor, torques of up to 8270 Nm can arise and these must be taken up by the turbopump and frame. Pumps must be anchored as follows:
  - ISO flange with 6 bracket screws, or
  - CF flange with the complete set of M8 screws, or
  - underside of the pump with 8 screws M8, screws quality 8.8.

### 3.2. Installing The Pump, Connecting The High Vacuum Side



The utmost cleanliness must be observed when fitting all high vacuum parts. Unclean components prolong the pumping time.

#### Using the splinter shield

The use of a splinter shield (accessory) in the high vacuum flange protects the turbopump against foreign bodies coming from the vacuum chamber but does reduce the volume flow rate of the pump by approximately 15%.

For fitting splinter shields please refer to "Fitting the splinter shield".

The high vacuum side can be flanged directly to the vacuum chamber or via a bellows or a vibration compensator (accessory).

#### Connecting Via A Bellows

If the high vacuum side is to be flanged via a bellows, the turbopump must be secured for example via the holes on the underside of the turbopump (please see "Dimensions").

The fastening must be able to withstand the torque referred to in Section 3.1.

#### Connecting Via A Vibration Compensator



The maximum permissible temperature at the vibration compensator is 100°C.

Where a vibration compensator is in use constructional advice from the manufacturer must be requested.

#### Directly Flanging The Pump

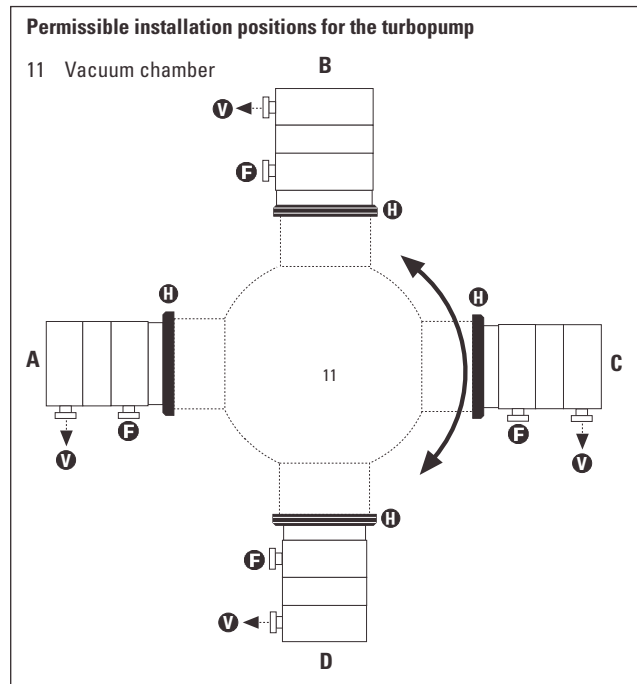

The maximum loading capacity of the high vacuum flange is 2000 N (equivalent to 200 kg). Asymmetric loading on the high vacuum flange must be avoided.

Shaking the pump can cause overloading on the magnetic bearing; this can lead to activation of the safety bearing. Therefore avoid shaking as far as is possible. Where incitement from the system is involved, for example via a high vacuum valve, the pump must be secured in such a way that no movement is possible, especially tilting movement.

Where rotary vane vacuum pump backing pumps with installation position A or C are involved the fore-vacuum flange must point downwards.

The use of rotary vane vacuum pumps is not recommended where installation position B has been selected.



No forces from the piping system must be allowed to act on the pump where turbopumps are anchored.

Suspend or support all pipes to the pump.

### Fitting The Splinter Shield (Accessory)

- ➔ Insert the splinter shield in the ISO-K flange in condition on delivery.

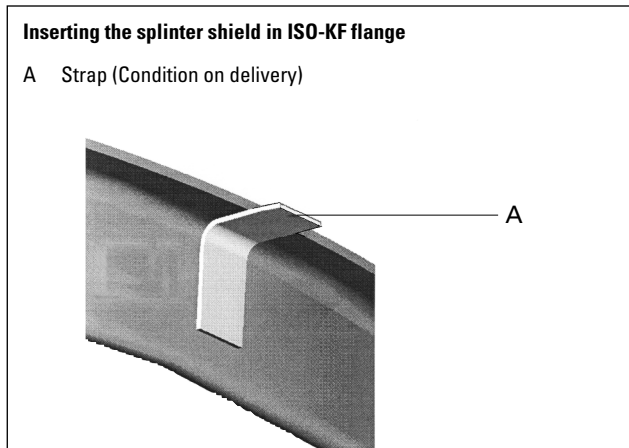

- ➔ Before insert the splinter shield in the CF flange the strap **must** be bent.

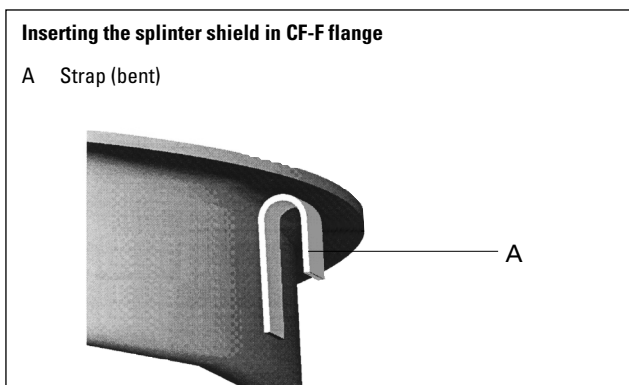

### 3.3. Connecting The Fore-Vacuum Side

Recommended PFEIFFER backing pump:

- dry compressing diaphragm pump
- for large vacuum chambers UniDry™ 050-3.

#### Connecting the backing pump

All connections of the fore-vacuum line: With the usual small flange components or hose screw connections.



Be sure to conduct away the exhaust gases from the backing pump. Do not reduce the free cross section of the fore-vacuum flange with following components.



The exhausted process gases and vapours can represent a health hazard and can also be environmentally damaging. Comply with all the gas manufacturer's safety instructions.

- ➔ Fit the delayed opening fore-vacuum safety valve (e.g. TVV 001, Accessory) in the fore-vacuum line (in PFEIFFER rotary vane vacuum pumps already integrated as standard). This prevents the vacuum chamber being ventilated via the backing pump.
- ➔ With rigid pipe connections: Fit a bellows in the connecting line to reduce vibration.

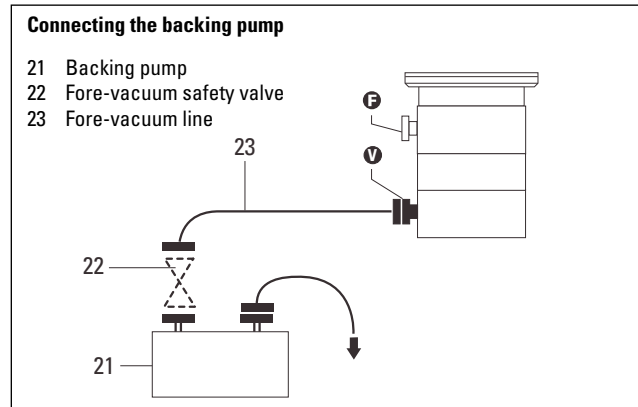

- ➔ The electrical connection of the backing pump: Please see the operating instructions for the Magnetic Bearing Controller TCM 1601, PM 800 478 BN.

### 3.4. Connecting The Cooling Unit

The Turbopumps TMH/TMU 1600M are water cooled as standard.

The permissible ambient temperature for water cooling is 35 °C.

When operating with reduced levels of gas load, air cooling is possible (please see "Accessories")

The permissible ambient temperature with air cooling is < 30 °C and the maximum gas flow and fore-vacuum pressure are reduced compared with water cooling (please refer to Section 8. Technical Data).

#### Water Cooling

The cooling water can be drawn either

- from the cooling water mains or
- from Recycled Water Cooling Unit TZK in closed circuit.

#### Cooling from the cooling water mains

To prevent deposits collecting in the pump the cooling water must be filtered.

The minimum requirements for the cooling water:

Mechanically clean, optically clear, no turbidity, no sediment, chemically neutral and temperature > dew point.

Oxygen content:	max. 4 mg/kg
Chloride content:	max. 100 mg/kg
Carbonate hardness:	max. 10 ° dH
Consumption of potassium permanganate:	max. 10 mg/kg
Carbon dioxide:	Undetectable
Ammonia:	Undetectable
pH-value:	7 – 9
Max. fore-line over pressure:	max. 6 bar
Minimum flow rate:	see 8. "Technical Data"

### Connection to the cooling water mains

- ➔ Fit the dirt trap (Accessory) in the supply line.
- ➔ Connect the supply line with hose clips onto one of the two cooling water connections.
- ➔ Connect Cooling Water Monitor TCW 002 in return line.
- ➔ Connect the return line to the other cooling water connection of the turbopump.
- ➔ Tighten all hose clips and check for firm seating of the hoses.
- ➔ Tighten the hollow screws on the cooling water connection to a torque of 20 Nm.

#### Cooling from the cooling water mains

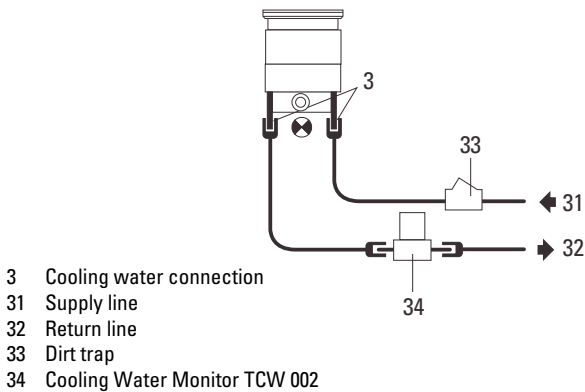

### Cooling with the Recycled Water Cooling Unit TZK (Accessory)

Dirt traps in the fore-lines are not necessary.  
All other steps as for connecting to the cooling water mains.

#### Cooling with Recycled Water Cooling Unit TZK

- 3 Cooling water connection  
34 Cooling Water Monitor TCW 002  
35 Recycled Water Cooling Unit TZK

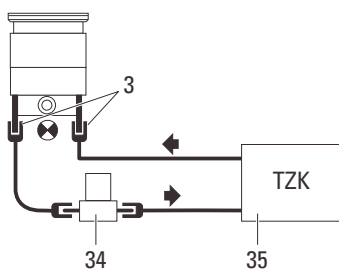

### Air Cooling (Accessory)



Air cooling is only permissible where the ambient temperature is < 30 °C.  
Ensure that the supply and exhaust air ducts are not restricted.

#### Fitting the air cooling unit

- ➔ Place a fluff-free and clean pad on the working surface.

- ➔ Place the pump on its high vacuum flange (Caution: do not damage the sealed surfaces).
- ➔ Pull out the synthetic feet from the base of the pump.
- ➔ Screw air cooling to the holder 37 with 4 screws M8 and spring washers onto the turbopump. The fan have to be installed parallel to the electric connection.

#### Fitting the air cooling unit

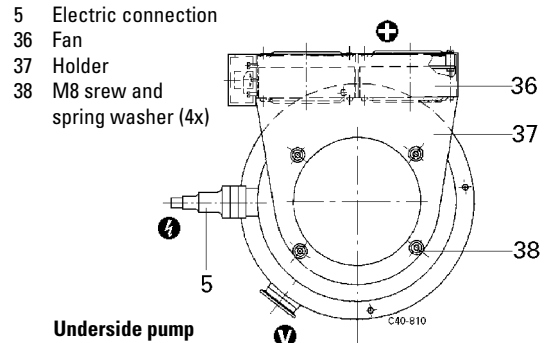

#### Electrical connection, air cooling

- ➔ The electrical connection of the air cooling unit is made on the control line 57 (please see Section 3.8.) on the connecting cable TCM-turbopump (see the operating instructions for the TCM 1601, PM 800 478 BN).

Alternatively, either the casing heating unit or the TMS can be connected to the control line. Simultaneous operations of the functions is not possible.

### 3.5. Connecting The Venting Valve



Uncontrolled venting can cause overloading on the axial bearing resulting in activation of the safety bearing. The TMH/TMU 1600M may only be vented via the venting valve fitted. It must not be replaced by other venting equipment.

Maximum pressure on the venting valve: 1.5 bar absolute.

If a higher venting rate is required further venting components can be opened as soon as the rotation speed of the pump is less than 100 Hz.

If, from the beginning, the pump is to be vented with equipment other than that fitted, the pressure increase on the high vacuum flange must be limited to 2 mbar/s until the rotation speed is less than 100 Hz.

#### Electrical connection, venting valve

The electrical connection of the venting valve is via the connecting cable magnetic bearing controller - turbopump.

- ➔ Connect the plug from the cable junction to the venting valve and secure with screw.

Please also refer to the connections diagram for the TCM 1601 in Operating Instructions PM 800 478 BN.

### 3.6. Connecting The Sealing Gas

To protect the pump, particularly where corrosive or dust producing processes are involved, it is necessary to use sealing gas. Connection is made via the sealing gas valve (please see "Accessories").



For this, please refer to Section 2.1. "Main Features" for the sealing gas connection.

Please refer to Operating Instructions PM 800 229 BN for details on installing the sealing gas valve and adjusting the sealing gas flow.

### 3.7. Connecting The Casing Heating Unit

Final pressures are attained more rapidly when turbopump and vacuum chamber are heated. The heating duration is dependent on the degree of contamination and on the required final pressure. The heating should last for at least 4 hours.



Where casing heating unit is involved the turbopump must be water cooled.



High temperatures arise when baking out turbopumps and vacuum chambers. There is a danger of burns from touching hot parts, even after the heating has been switched off.

Ideally, the heating sleeve, pump casing and vacuum chamber should be insulated during installation. When baking out do not touch the heating sleeve, pump casing and vacuum chamber.

- ➔ Screw the heating sleeve tightly onto the casing with the securing screws and fit protection against accidental contact.
- ➔ Electrical connection, casing heating unit: Please see Operating Instructions PM 800 478 BN for the TCM 1601.

### 3.8. Connecting The Magnetic Bearing Controller

- ➔ Plug in the connecting cable between the magnetic bearing controller and the turbopump.



Caution! Take care to ensure that the cable plugs are put straight onto the built-in plugs to avoid damage to the connecting points. For details please refer to the operating instructions for the Magnetic Bearing Controller

TCM 1601/PM 800 478 BN.

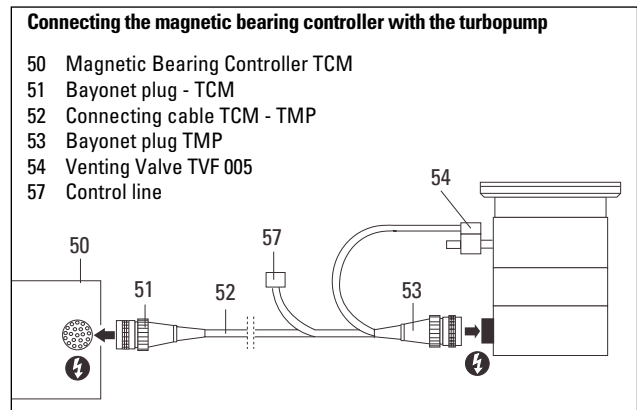

Before disconnecting the plug connection:

- Rotor rotation speed = 0 Hz
- Disconnect the magnetic bearing controller from the mains.



Voltages of up to 150 V can be present on the open contacts of a running-down pump. There is a danger of an electrical shock from touching the contacts.

### 3.9. Connecting The Temperature Management System (TMS)

Pumps with the designation TMH 1600M T/TMU 1600M T (please see the rating plate) can be heated to a maximum of 90 °C in the Holweck stages range with the heaters and temperature sensors (TMS) integrated in the middle casing. During TMS operations the additional flange heating for the turbomolecular pump is not possible.



During TMS operations the turbopump must be operated with water cooling.

For connection and operation of the temperature management system (TMS) please refer to operating instructions for the TMS, PM 800 517 BN and for the TCM 1601, PM 800 478 BN.

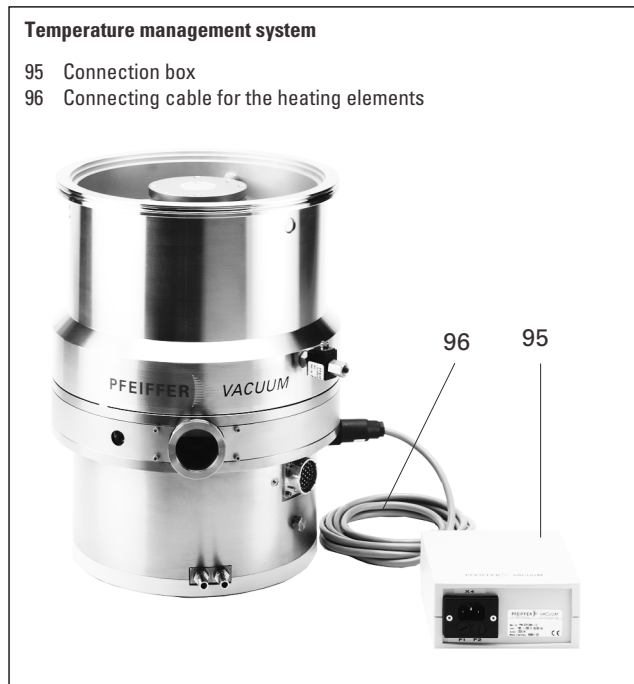

## 4. Operations

### 4.1. Before Switching ON



Turbopump rotors rotate at high speed. When the high vacuum flange is open there is a danger of injury and of damage to the pump caused by objects falling into the pump. Therefore never operate the pump with open high vacuum flange.



When operating with casing heating unit or TMS operations high temperatures can arise on the pump surfaces.

- ➔ Pre-select the required operational functions and parameters on the Magnetic Bearing Controller TCM 1601.
- ➔ With water cooling: Open cooling water supply and check flow.

### 4.2. Switching ON

- ➔ Switch on the magnetic bearing electronic controller with switch S1 on the rear side of the TCM 1601.
- ➔ Switch on the pumping station with the push button  on the front panel of the TCM 1601.
  - If air cooling is involved the cooling fan is also switched on by the magnetic bearing controller.
  - The backing pump is automatically started with the Pumping Station Control Unit TCS 180.

- ➔ Switch on the backing pump if it is not switched via the pumping station control unit.



Take care when pumping hazardous gases and observe the safety precautions of the gas manufacturer.

### 4.3. Heating (only for pumps with casing heating unit)

The heating duration is dependent on the degree of contamination and on the required final pressure. The heating should last for at least 4 hours.



Where casing heating unit is involved the turbopump must be water cooled.

- ➔ Switch on the turbopump heating in the menu of the Magnetic Bearing Controller TCM 1601 (please see Operating Instructions PM 800 478 BN for the TCM 1601).

#### 4.4. Operations With The TMS

If the pump is equipped with the temperature management system (TMS) (TMH/TMU 1600M C T, see rating plate), heating is possible in the area of the pressure stages with the heaters integrated in the middle casing part and temperature sensors up to a maximum of 90 °C.

- ➔ Connect the TMS to the magnetic bearing controller. For connection diagram, function and circuit diagram please refer to the operating instructions for the TMS, PM 800 517 BN and for the TCM 1601 PM 800 478 BN.
- Condensable media may only be pumped once the selected TMS temperature has been attained.

In order to optimize the performance of the pump in gas load operations and to ensure temperature stability, the rotation speed of the pump in the TMS mode is slightly reduced by activating the TMS heating. For specific rotation speeds in the TMS mode please refer to Section 8, "Technical Data".

As a matter of principle, TMS heating is only activated on attainment of the rotation speed switchpoint.

#### 4.5. Intermittent Mode Operations Of The Backing Pump

Where Pumping Station Control Unit TCS 180 is in operation there is the option, under certain pre-conditions, to select intermittent mode operations on the diaphragm pump (please refer to the Section "Operations With Pumping Station Control Unit TCS 180 in the TCM 1601 Operating Instructions PM 800 478 BN).

If the setting procedure described there cannot be executed the guide values  
 <710: **BkP Poff**> = 150 W und  
 <711: **BkP Pon**> = 280 W  
 can be used for the switch on and switch off thresholds.



The TMH 1600M P C H can not be operated in connection with a diaphragm pump.

#### 4.6. Gas Type Dependent Operations

Where high level gas loads and rotation speeds are involved, the resulting friction subjects the rotor to the effect of great heat. To avoid over-heating, a power rotation speed characteristic line is implemented in the TCM 1601; this ensures that where maximum gas loads are involved, the pump will operate at any rotation speed without the danger of damage arising.

The maximum power is dependent on the type of gas. Two characteristic lines are available for any type of gas in order to fully exploit the power potential of the pump:

- "Gas-Mode 0" for gases with molecular mass  $\geq 40$  as, for example, Argon;
- "Gas-Mode 1" for all lighter gases.

- ➔ Set the applicable gas mode on the TCM 1601 (please refer to Operating Instructions PM 800 478 BN for the TCM 1601).



Pumping gases with molecular mass  $\geq 40$  with the incorrect gas mode can cause damage to the pump.

For the vertex of the power characteristic line please refer to Section 8. Technical Data.

Maximum power is applied when the pump starts in order to limit the time required. Once the set rotation speed is attained, switching to the selected power characteristic line is automatic.

If the gas dependent maximum power is exceeded, the rotation speed is reduced until equilibrium between the permissible power and gas friction is attained. The power limitation serves to protect the pump against thermal overloading. In order to avoid rotation speed fluctuations it is recommended to set, in rotation speed setting mode, the equilibrium frequency or a somewhat lower frequency.

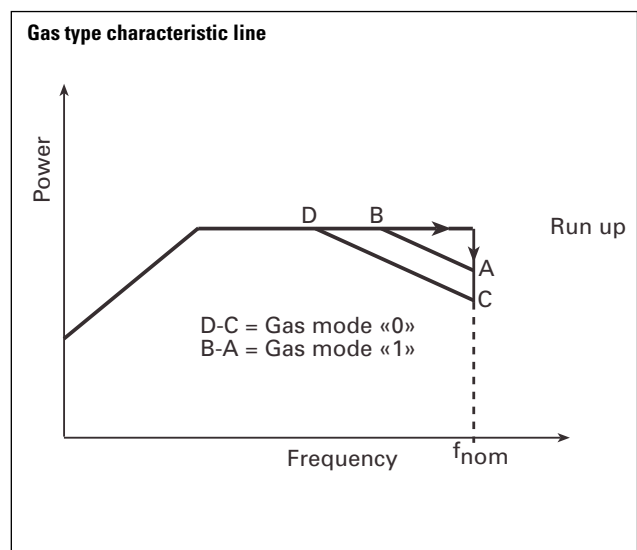

## 4.7. Safety Bearings

Where heavy, external vibration or improper operating is involved, the rotor is supported by an additional, dry-running safety bearing; a clearly audible sound is produced when this happens. The various causes are evaluated as follows:

- Power failure; Display Warning F 007;  
only low level strain on the safety bearing and, with a new safety bearing set, possible 100 times.
- Uncontrolled venting or vibration;  
Malfunction Display E 089;  
medium level strain on the safety bearing, and, with a new safety bearing set, possible 50 times.
- Cable disconnected between the electronics and the pump; Malfunction Display E 082;  
high level strain on the safety bearing, and, with a new safety bearing set, possible 5 times.

If there is a mix of the events referred to above, the criteria for the actual wear of the safety bearing is the sum of the partial wear arising from the individual events.

Please get in touch with your local PFEIFFER Service when a safety bearing replacement is required.

## 4.8. Switching OFF And Venting

When switching off and venting the turbopump please take account of the fact that various venting modes are available (please refer to the operating instructions for the TCM 1601, PM 800 478 BN).

- ➔ Switch off the pumping station with the push button  on the front panel of the TCM 1601.
- ➔ Close the fore-vacuum safety valve (if available). Where Pumping Station Control Unit TCS 180 is involved, the valve closes automatically.
- ➔ With water cooling: Shut off the water supply.
- ➔ Shut off the supply of sealing gas if operating with sealing gas.
- ➔ Do not switch off the TCM 1601 or disconnect from the mains until the rotation speed has reached 0 Hz.



When operating the pump with aggressive gases and their reactive products, the operation of the backing pump and the sealing gas function should be continued for at least 15 minutes in order to protect the bearings and the drive and to ensure the complete pumping out of this media.

## 4.9. Shutting Down For Longer Periods



Vacuum pumps are sometimes used to pump aggressive or hazardous gases. There is a danger of personal injury resulting from coming into contact with process gases. Before removing a turbopump from the system, first:

- Vent the turbopump with a neutral gas or dry air.
- Ensure that there is no residual process gas in the system nor in the supply lines.

If the turbopump is to be shut down for more than a year:

- ➔ Remove turbopump from the system.
- ➔ Close the high vacuum flange and evacuate the turbopump via the fore-vacuum flange.
- ➔ Vent turbopump via the venting connection with nitrogen or dry air.
- ➔ Close fore-vacuum connection by blank flanging.
- ➔ Place the pump vertically on its synthetic feet.
- ➔ In rooms with moist or aggressive atmospheres, the turbopump must be air-sealed in a plastic bag together with a bag of dessicant, e.g. silicagel.

## 5. What To Do In Case Of Breakdowns ?

The Magnetic Bearing Controller TCM 1601 contains an integrated malfunction diagnosis system (error code table). The malfunction messages are explained in operating instructions for the TCM 1601, PM 800 478 BN and their possible causes are listed.

Problem	Possible causes	Remedy
Pump doesn't start	<ul style="list-style-type: none"> <li>• Power supply interrupted</li> </ul>	<ul style="list-style-type: none"> <li>• Check fuse in the magnetic bearing controller</li> <li>• Check plug contacts on the magnetic bearing controller</li> <li>• Check supply line</li> </ul>
Pump doesn't attain nominal rotation speed within the set start-up time; Pump cuts out during operations	<ul style="list-style-type: none"> <li>• Fore-vacuum pressure too high</li> <li>• Leak or too much gas</li> <li>• Start-up phase in the magnetic bearing controller set too short</li> <li>• Thermal overloading caused by               <ul style="list-style-type: none"> <li>– flow insufficient</li> <li>– air supply insufficient</li> <li>– fore-vacuum pressure too high</li> <li>– ambient temperature too high</li> </ul> </li> </ul>	<ul style="list-style-type: none"> <li>• Check backing pump function</li> <li>• Check seals</li> <li>• Seek leak and repair</li> <li>• Reduce gas load</li> <li>• Increase the start-up phase</li> <li>• Ensure free flow</li> <li>• Ensure adequate air supply</li> <li>• Reduce fore-vacuum pressure</li> <li>• Reduce ambient temperature</li> </ul>
Pump doesn't attain final pressure	<ul style="list-style-type: none"> <li>• Pump dirty</li> <li>• Leak in vacuum chamber, lines or pump</li> </ul>	<ul style="list-style-type: none"> <li>• Bake out pump</li> <li>• If seriously contaminated: Request PFEIFFER Service to clean</li> <li>• Seek leak starting with vacuum chamber</li> <li>• Repair leak</li> </ul>
Unusual operating noises	<ul style="list-style-type: none"> <li>• Rotor damaged</li> <li>• Splinter shield (if fitted) not seated firmly</li> <li>• Pump runs in the safety bearings</li> </ul>	<ul style="list-style-type: none"> <li>• Inform PFEIFFER Service of need for repair</li> <li>• Check seat of splinter shield (see Section 3.2.)</li> <li>• Remove the cause; start the pump again</li> </ul>

## 6. Maintenance



No liability for personal injury nor material damage will be accepted for damages and operational interruptions which have been caused by improper maintenance; in addition, all guarantees become invalid.

Your pump can be cleaned on the spot if it is not very dirty. Please check procedures with your local PFEIFFER Service Center.

Your local PFEIFFER Service can advise you regarding cleaning procedures and any other maintenance and service work.

## 7. Service

### Do Make Use Of Our Service Facilities

In the event that repairs are necessary a number of options are available to you to ensure any system down time is kept to a minimum:

- Have the pump repaired on the spot by our PFEIFFER Service Engineers;
- Return the pump to the manufacturer for repairs;
- Replace the pump.

Local PFEIFFER representatives can provide full details.

### Before Returning:

- ➔ Please attach a clearly visible notice "Free of harmful substances" (both on the unit and also on the delivery note and any accompanying letters).

"Harmful substances" are substances and preparations as defined in the current, local, dangerous substances regulations; in the U.S.A. as "materials in accordance with the Code of Federal Regulations (CFR) 49 Part 173.240 Definition and Preparation".

We will carry out the decontamination and invoice this work to you if you have not attached this note. This also applies where the operator does not have the facilities to carry out the decontamination work. Units which are contaminated microbiologically, explosively or radioactively cannot be accepted as a matter of principle.

### Fill Out The Declaration Of Contamination

- ➔ In every case the "Declaration of Contamination" must be completed diligently and truthfully.
- ➔ A copy of the completed declaration must accompany the unit; any additional copies must be sent to your local PFEIFFER Service Center.

Please get in touch with your local PFEIFFER representatives if there are any questions regarding contamination.



Decontaminate units before returning or possible disposal. Do not return any units which are microbiologically, explosively or radioactively contaminated.

### Returning Contaminated Units

If contaminated have to be returned for maintenance/repair, the following instructions concerning shipping must be followed:

- ➔ Neutralise the pump by flushing with nitrogen or dry air.
- ➔ Seal all openings to the air.
- ➔ Seal pump or unit in suitable protective foil.
- ➔ Ship units only in appropriate transport containers.



Repair orders are carried out according to our general conditions of sale and supply. If repairs are necessary, please send the pump to your nearest PFEIFFER Service Center.

### Contact Addresses And Telephone Hotline

Contact addresses and telephone numbers can be found on the back cover of these operating instructions.

## 8. Technical Data

Feature	Unit	TMH 1600M TMU 1600M	TMH 1600M TMU 1600M	TMH 1600M H
Connection nominal diameter: Inlet		DN 200 ISO-K DN 200 CF-F	DN 250 ISO-K DN 250 CF-F	DN 200 ISO-K    DN 250 ISO-K
Outlet		DN 40 ISO-KF		DN 40 ISO-KF
Magnetic bearing controller		TCM 1601		TCM 1601
Nominal rotation speed without TMS	1/min	36 000		36 000
Nominal rotation speed with TMS	1/min	33 000		33 000
Standbyrotation speed	1/min	24 000		24 000
Start-up time (up to 90% of the nominal rotation speed with TCM 1601) (bis 90 % Nenndrehzahl mit TCM 1601)	min	6		7
Noise level	dB (A)	55		55
Maximum permissible rotor temperature	°C	120		120
Permissible heat radiation power	W	27		27
Volume flow rate (with oil-sealed rotary vane vacuum pump):				
Stickstoff N <sub>2</sub>	l/s	1000	1400	1000    1400
Helium He	l/s	1100	1180	1100    1230
Wasserstoff H <sub>2</sub>	l/s	750	780	750    850
Compression ration for:				
N <sub>2</sub>	–	$> 1 \cdot 10^{10}$		$> 1 \cdot 10^8$
He	–	$5 \cdot 10^5$		$2 \cdot 10^4$
H <sub>2</sub>	–	$1 \cdot 10^4$		$2 \cdot 10^3$
Critical backing pressure, max. N <sub>2</sub> Cooling type: water	mbar	9		3
Gas throughput without TMS operation at nominal rotation speed, max.				
N <sub>2</sub> Cooling type: water	mbar l/s	9		15
Ar    Cooling type: water	mbar/l/s	4,5		6
Gas throughput with TMS operation at nominal rotation speed, max <sup>1)</sup>				
N <sub>2</sub> Cooling type: water	mbar/l/s	7		12
Ar    Cooling type: water	mbar/l/s	3,5		5
Gas throughput at 0,1 mbar intake pressure				
N <sub>2</sub> Cooling type: water	mbar/l/s	16		20
Ar    Cooling type: water	mbar/l/s	12		14
Vertex power characteristics line <sup>2)</sup>				
A	W / Hz	400		400
B	W / Hz	580		480
C	W / Hz	360		360
D	W / Hz	360		360
Theoretical final pressure	mbar	$< 1 \cdot 10^{-11}$		$< 1 \cdot 10^{-11}$
Final pressure 1 (metal seal with backing out)	mbar	$< 1 \cdot 10^{-10}$		–
Final pressure 2 (viton seal without backing out)	mbar	$< 1 \cdot 10^{-8}$		$< 5 \cdot 10^{-8}$
Cooling water consumption with water at 15 °C				
without TMS operation	l/h	20		20
with TMS operation and gas load	l/h	100		100
Cooling water temperature	°C	5 - 25		5 - 25
Permissible ambient temperature with				
air cooling	°C	5 - 30		5 - 30
water cooling	°C	5 - 35		5 - 35
Power consumption of:				
casing heating unit	W	170		170
TMS heating	W	1000		1000
Permissible magnetic field	mT	4		4
Protection class		IP 20		IP 20
Weight	kg	61/63	62/64	61    63
Relative humidity	%	5-85 non-condensing		5-85 nicht betauend

- 1) Operation with TMS only with water cooling
- 2) For gas type characteristics line please refer to Section 4.6.



## 9. Spare Parts

Pos.	Description	Pieces	Size	Number	Comments	Ordering Quantity
<b>Spare parts TMH/U 1600M</b>						
6	Synthetic foot	4		P 4098 582 FA	see Section 2.1.	
16	USIT ring	2		P 3529 133 -A		
54	Venting Valve TVF 005	1	G 1/8"	PM Z01 135	see Section 2.1.	
97	Temperature sensor, complete	1		PM 073 593 -X	see Section 3.9.	
<b>Spare parts for the air cooling unit</b>						
36	Fan	1	110 V / 230 V	P 5099 251 -R7		
36a	Finger protection	2		P 5099 251 Z4		
36b	Buffer	4		P 0991 099		

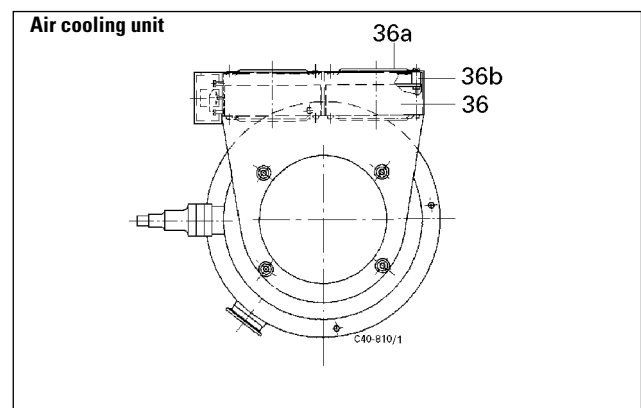
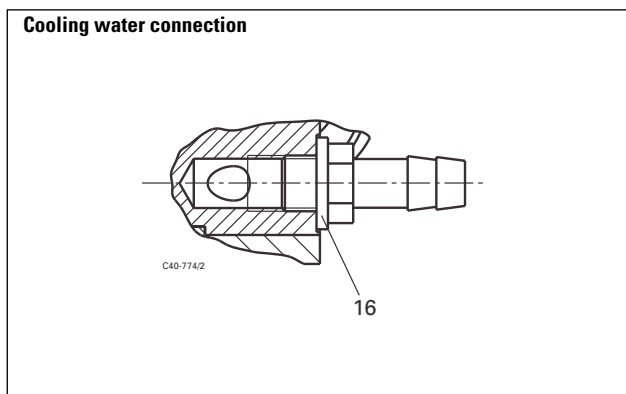

## 10. Accessories

Description	Size	Number	Operating Instructions/ Comments	Order Quantity
Magnetic Bearing Controller TCM 1601	90 - 265 V; 50/60 Hz	PM C01 675	PM 800 478 BN	
Connecting cable turbopump - TCM	3 m	PM 051 003 -T	other lengths on request	
Pumping Station Control Unit TCS 180	100 - 115/230 V; 50/60 Hz	PM C01 655	PM 800 384 BN	
Casing heating unit	230 V AC, Safety plug 208 V AC, UL plug 115 V AC, UL plug	PM 016 070 -T PM 016 071 -T PM 016 072 -T	Water cooling required	
Protective grill	DN 200 DN 250	PM 016 039 AX PM 016 077 -X		
Splinter shield	DN 200 DN 250	PM 006 985 AX PM 006 984 AX		
Sealing ring, TMH	DN 200 ISO-K DN 250 ISO-K	PF 303 120 -T PF 303 125 -T		
Collar flange with retaining ring, TMH	DN 200 ISO-K DN 250 ISO-K	PF 307 120 -T PF 307 125 -T		
Cu seals (10 pieces), TMU (5 pieces)	DN 200 CF DN 250 CF	PF 501 420 -T PF 501 425 -T		
Set of screws, TMU	DN 200 CF DN 250 CF	PF 505 003 -T PF 505 003 -T		
Vibration compensator, TMH  TMU	DN 200 ISO-K DN 250 ISO-K DN 200 CF-F DN 250 CF-F	PM 006 668 -X PM 006 670 -X PM 006 669 -X PM 006 671 -X		
Fore-Vacuum Safety Valve TVV 001	115 V 230 V	PM Z01 206 PM Z01 205	PM 800 263 BN only with TCS 180	
Drying Unit TTV 001 (filled with zeolite)		PM Z00 121	PM 800 022 BN	
Sealing gas valve Hose nipple for the sealing gas valve	DN 16 ISO-KF-10	PM Z01 142 PF 144 020	PM 800 229 BN	
<b>Components for cooling</b>				
Dirt trap	R 3/8"	P 4161 300 2R		
Recycled Water Cooling Unit TZK 400	230 V, 50 Hz	PM Z01 245	PM 800 369 BN	
Set for air cooling	230 V AC, Safety plug 208 V AC, UL plug 115 V AC, UL plug	PM Z01 275 PM Z01 276 PM Z01 277		
Cooling Water Monitor TCW 002	110 V, 50/60 Hz 220 V, 50/60 Hz 240 V, 50/60 Hz	PM C00 131 PM C00 130 PM C00 132	PM 800 133 BE	
Connection component set for the TCW 002		PM 006 802 -T		

When ordering accessories and spare parts please be sure to state the full part number. When ordering spare parts please state additionally the unit type and unit number (see rating plate). Please use this list as an order form (by taking a copy).

## Declaration of Contamination of Vacuum Equipment and Components

The repair and/or service of vacuum components will only be carried out if a correctly completed declaration has been submitted. Non-completion will result in delay.

The manufacturer could refuse to accept any equipment without a declaration.

**This declaration can only be completed and signed by authorised and qualified staff:**

**1. Description of component:**

- Equipment type/model: \_\_\_\_\_
- Code No.: \_\_\_\_\_
- Serial No.: \_\_\_\_\_
- Invoice No.: \_\_\_\_\_
- Delivery Date: \_\_\_\_\_

**2. Reason for return:**

\_\_\_\_\_

\_\_\_\_\_

\_\_\_\_\_

\_\_\_\_\_

**3. Equipment condition**

- Has the equipment been used?  
yes  no
- What type of pump oil was used?  
\_\_\_\_\_
- Is the equipment free from potentially harmful substances?  
yes  (go to section 5)  
no  (go to section 4)

**4. Process related contamination of equipment**

- toxic yes  no
- corrosive yes  no
- microbiological hazard\*) yes  no
- explosive\*) yes  no
- radioactive\*) yes  no
- other harmful substances yes  no

\*) We will not accept delivery of any equipment that has been radioactively or microbiologically contaminated without written evidence of decontamination!

Please list all substances, gases and by-products which may have come into contact with the equipment:

Tradename Product name Manufacturer	Chemical name (or Symbol)	Danger class	Precautions associated with substance	Action if spillage or human contact
1.				
2.				
3.				
4.				
5.				

### 5. Legally Binding Declaration

I hereby declare that the information supplied on this form is complete and accurate. The despatch of equipment will be in accordance with the appropriate regulations covering Packaging, Transportation and Labelling of Dangerous Substances.

Name of Organisation: \_\_\_\_\_

Address: \_\_\_\_\_ Post code: \_\_\_\_\_

Tel.: \_\_\_\_\_

Fax: \_\_\_\_\_ Telex: \_\_\_\_\_

Name: \_\_\_\_\_

Job title: \_\_\_\_\_

Date: \_\_\_\_\_ Company stamp: \_\_\_\_\_

Legally binding signature: \_\_\_\_\_

## **Herstellereklärung** **Manufacturer's Declaration**

im Sinne folgender EU-Richtlinien:  
*pursuant to the following EU directives:*

- **Maschinen/Machinery 98/37/EG**
- **Elektromagnetische Verträglichkeit/Electromagnetic Compatibility 89/336/EWG**
- **Niederspannung/Low Voltage 73/23/EWG**

Hiermit erklären wir, daß das unten aufgeführte Produkt zum Einbau in eine Maschine bestimmt ist und daß deren Inbetriebnahme so lange untersagt ist, bis festgestellt wurde, daß das Endprodukt den Bestimmungen der EU-Richtlinie 98/37/EG, Anhang II B entspricht.

Wir bestätigen Konformität mit der EU-Richtlinie über elektromagnetische Verträglichkeit 89/336/EWG und der EU-Niederspannungsrichtlinie 73/23/EWG.

*We hereby certify that the product specified below is intended for installation in a machine which is forbidden to be put into operation until such time as it has been determined that the end product is in accordance with the provision of EU Directive 98/37/EEC, Annex II B.*

*We certify conformity with EU Electromagnetic Compatibility Directive 89/336/EEC and EU Low Voltage Directive 73/23/EEC.*

**Produkt/Product:**

**TMH 1600M**

**TMU 1600M**

Angewendete Richtlinien, harmonisierte Normen und angewendete, nationale Normen:

*Guidelines, harmonised standards, national standards in which have been applied:*

**EN 292-1**

**EN 292-2**

**EN 294**

**EN 1012-2**

**EN 61010-1**

Unterschrift/Signature:



Pfeiffer-Vacuum GmbH  
Emmeliusstrasse 33  
35614 Asslar  
Germany

(W. Dondorf)  
Geschäftsführer  
Managing Director

Herst.I./2000

**Zentrale/Headquarters**

Pfeiffer Vacuum GmbH  
 Emmeliusstrasse 33  
 D-35614 Asslar  
 Telefon 06441/802-0  
 Telefax 06441/802-202  
 Hotline 06441/802-333  
 Internet:  
<http://www.pfeiffer-vacuum.de>

**Argentina**

ARO S.A., Casilla de Correo 4890,  
 1000 Buenos Aires, telephone +54 / 1 331 3918,  
 telefax +54 / 1 331 3572

**Australia**

Balzers Australia Pty. Ltd., Level 1,  
 3, Northcliff Street, Milsons Point, NSW 2061,  
 telephone +61 / 2 9954 1925, telefax +61 / 2 9954 1939

**Austria**

Pfeiffer Vacuum Austria GmbH  
 Diefenbachgasse 35, A-1150 Wien,  
 telephone +43 / 1 8941 704, telefax +43 / 1 8941 707  
 Service Hotline: +43 / 1 8941704

**Branch Office, Czech Republic**

Pfeiffer Vacuum Austria GmbH, Branch Prague  
 Zvonarska 885  
 CZ-156 00 Praha 5  
 telephone + 420/2 900 42981  
 telefax + 420/2 579 23014

**Belgium / Luxemburg**

Pfeiffer Vacuum Belgium N.V./S.A.  
 Luxemburgstraat 5, B-1940 Temse  
 telephone +32 / 3 710 5920, telefax +32 / 3 710 5929  
 Service Hotline: +32 / 3 710 5922

**Brazil**

Elmi Tec  
 Assistencia Técnica e Representação S/C Ltda.  
 Rua Bernadino de Compos, 551  
 CEP 04620-002 São Paulo, SP - Brasil  
 telephone +55 / 11 532 0740  
 telefax +55 / 11 535 3598

**Chile**

BERMAT S.A., Coyancura 2283, piso 6  
 Providencia, P.O. Box 9781, Santiago  
 telephone +56 / 2 231 8877,  
 telefax +56 / 2 231 4294

**Colombia**

Arotec Colombiana S.A., Carrera 15 No.38-17  
 P.O. Box 050 862, Santafe de Bogota / D.C.  
 telephone +57 / 1 288 7799, telefax +57 / 1 285 3604

**Denmark**

Pfeiffer Vacuum Scandinavia AB, Vesterengen 2,  
 DK-2630 Taastrup,  
 telephone +45 / 43 52 38 00  
 telefax +45 / 43 52 38 50

**France**

Pfeiffer Vacuum France SAS  
 45, rue Senouque, BP 139 F-78531 BUC Cedex  
 telephone +33 / (0)1 30 83 04 00  
 telefax +33 / (0)1 30 83 04 04

**Germany**

Pfeiffer Vacuum GmbH,  
 Emmeliusstrasse 33, D-35614 Asslar  
 telephone +49 / 6441 802 400  
 telefax +49 / 6441 802 399  
 Service Hotline: +49 / 6441 802 333

**Great Britain**

Pfeiffer Vacuum Ltd.  
 2-4 Cromwell Business Centre  
 Howard Way, Interchange Park  
 Newport Pagnell, MK16 9QS, United Kingdom  
 telephone +44 / 1 908 500615  
 telefax +44 / 1 908 500616

**Greece**

Analytical Instruments S.A., 1 Mantzarou St.,  
 GR-15451 Athens,  
 telephone +30 / 1 674 8973  
 telefax +30 / 1 674 8978

**India**

Pfeiffer Vacuum India Ltd.  
 25-E Nicholson Road, Tarbund  
 Secunderabad 500 009,  
 telephone +91 / 40 775 0014, telefax +91 / 40 775 7774

**Israel**

ODEM Scientific Applications,  
 2 Bergman Street, Science based park  
 Rehovod  
 telephone +972 8 9366 101,  
 telefax +972 8 9366 102

**Italy**

Pfeiffer Vacuum Italia S.p.a.  
 Via San Martino, 44 I-20017 RHO (Milano)  
 telephone +39 / 2 93 99 051, telefax +39 / 2 93 99 05 33

**Japan**

Hakuto Co. Ltd., C.P.O. Box 25,  
 Vacuum & Scientific Instruments Division  
 Tokyo Central 100-91,  
 telephone +81 / 3 32 258 910  
 telefax +81 / 3 32 259 009

**Korea**

Pfeiffer Vacuum Korea Ltd., 3F Haein Building 453,  
 Dokok-Dong, Kang Nam-Ku, Seoul, 135-270  
 telephone +82 / 2 3461 0671/5  
 telefax +82 / 2 3461 0676

**Netherlands**

Pfeiffer Vacuum Nederland BV  
 Veldzigt 30a, NL-3454 PW De Meern,  
 telephone +31 / 30 6666050, telefax +31 / 30 6662794

**Peru**

Ing. E. Brammertz s.r.l., José Pardo 182,  
 Apartado 173, PE-18 Miraflores,  
 telephone +51 / 1 445 8178  
 telefax +51 / 1 445-1931

**Poland**

Softtrade Sp.z.o.o, ul. Malwowa 35,  
 PL-60-175 Poznan, telephone +48 / 61 8677 168,  
 telefax +48 / 61 8677 111

**Portugal**

Unilaser Lda, Taguspark  
 Núcleo Central, sala nº 268, Estrada Cacém-  
 Porto Salvo, P-2780 Oeiras  
 telephone +351 / 1 421 7733  
 telefax +351 / 1 421 7744

**Singapore**

APP Systems Services Pte. Ltd, 2 Corporation Road  
 06-14 Corporation Place, Singapore 618494,  
 telephone +65 / 268 2024, telefax +65 / 268 6621

**Spain**

Tecnovac  
 Tecnologia de Vacio S.L., Ronda de Poniente, 6 Bajo F  
 Centro Empresarial Euronova  
 E-28760 Tres Cantos (Madrid)  
 telephone +34 / 91 804 11 34,  
 telefax +34 / 91 804 30 91

**Sweden**

Pfeiffer Vacuum Scandinavia AB  
 Johanneslundsvägen 3  
 S-194 61 Upplands Väsby  
 telephone +46 / 590 748 10  
 telefax +46 / 590 748 88

**Switzerland**

Pfeiffer Vacuum Schweiz S.A.  
 Förrlibuckstraße 30, CH-8005 Zürich  
 telephone +41 / 1 444 2255,  
 telefax +41 / 1 444 2266

**South Africa**

Labotec Pty Ltd., P.O. Box 6553,  
 Halfway House  
 1685 Midrand  
 telephone +27 / 11 315 5434  
 telefax +27 / 11 315 5882

**Taiwan**

HAKUTO Taiwan Ltd. Hsinchu office No. 103,  
 Hsien Chen 11th Street, Jubei City,  
 HsinChu County, Taiwan, R.O.C.  
 (zip/postal code: 302)  
 telephone +886 / 3 554 1020  
 telefax +886 / 3 554 0867

**Thailand**

S & T Enterprises (Thailand) Ltd.  
 18th Floor, Chokchai Int'l Bldg.  
 690 Sukhumvit Road  
 Klongton, Klongtoey  
 Bangkok 10110  
 telephone +662 / 259 4623  
 telefax +662 / 259 6243

**U.S.A.**

Pfeiffer Vacuum, Inc.  
 24 Trafalgar Square  
 Nashua, NH 03063-1988  
 USA  
 telephone +1/ 603 578 6500  
 telefax +1/ 603 578 6550

**Venezuela**

Secotec S.A., Apartado 3452, Caracas 1010-A,  
 telephone +58 / 2 573 8687  
 telefax +58 / 2 573 1932

**Other countries**

AVI - Applied Vacuum Industries GmbH  
 Leginglenstrasse 17A; CH-7320 Sargans  
 Switzerland  
 telephone +41 / 81 710 03 80  
 telefax +41 / 81 710 03 81

**Scope of represented countries**

Armenia, Azerbaijan, Bangladesh, Belarus, Bulgaria,  
 Cambodia, Estonia, Georgia, Hong Kong, Kazakhstan,  
 Kingdom of Nepal, Kirghizia, Latvia, Lithuania,  
 Maldavia, Philippines, P.R. China, Rumania, Russia,  
 Tajikistan, Turkmenistan, Ukraine, Uzbekistan, Vietnam

**A.E.M.S.**

Advanced Equipment Materials and Systems  
 P.O. Box 25  
 Föhrenweg 18  
 FL-9496 Balzers  
 telephone +41 / 75 380 0550  
 telefax +41 / 75 380 0551

**Scope of represented countries**

Bahrain, Egypt, Iraq, Iran, Jordan, Kuwait, Lebanon,  
 Lybia, Oman, Pakistan, Saudi-Arabia, Sudan, Syria,  
 Turkey, United Arab Emirates, Yemen