

***Operating Instructions***

***TCP 5000***

---

***Electronic Drive Unit***



	Page		Page
<b>1. Safety Instructions .....</b>	<b>3</b>	<b>4. Operations.....</b>	<b>9</b>
<b>2. Understanding The TCP 5000 .....</b>	<b>4</b>	4.1. Switching ON The Electronic Drive Unit.....	9
2.1. For Your Orientation.....	4	Switching ON Via The Pumping Station Control Unit	
2.2. Product Description.....	4	TCS 130 .....	9
Monitoring Electronics .....	4	4.2. Starting The Turbopump .....	9
Signal Outputs .....	4	4.3. Operations At Nominal Rotation Speed .....	9
Connection Options .....	4	4.4. Stand-By Operations .....	9
STAND-BY Functions .....	4	4.7. Switching OFF.....	9
Remote Control.....	4	4.6. Operations With The Pumping Station Control Unit	
Proper Use .....	5	TCS 130 .....	9
Improper Use .....	5	<b>5. What To Do In Case Of Breakdowns? .</b>	<b>10</b>
2.3. Description Of The Front Panel.....	5	<b>6. Maintenance, Service .....</b>	<b>11</b>
2.4. Description Of The Rear Panel .....	5	<b>7. Technical Data.....</b>	<b>11</b>
<b>3. Installation.....</b>	<b>6</b>	7.1. Data List.....	11
3.1. Preparations For Installation.....	6	7.2. Dimensions Diagram .....	11
3.2. Fitting The Unit In A Rack .....	6	<b>8. Connections Diagram .....</b>	<b>12</b>
3.3. Mains Power Connection .....	6	<b>9. Accessories .....</b>	<b>13</b>
3.4. Connections Schematic.....	6	<b>Manufacturer's Declaration .....</b>	<b>Last page</b>
3.5. Connecting The Pump.....	7		
3.6. Connecting The Pumping Station Control Unit			
(Option) .....	7		
3.7. Connecting The Potential-Free Contacts.....	8		
3.8. Adjusting The Monitoring Electronics			
For Exceptional Applications .....	8		
3.9. Operating The Electronic Drive Unit TCP 5000			
With Accessories.....	9		

# 1. Safety Instructions

- ☞ Read and follow all the instructions in this manual.
- ☞ Inform yourself regarding:
  - Hazards which can be caused by the unit,
  - Hazards which can arise in your system,
- ☞ Comply with all safety and accident prevention regulations.
- ☞ Check regularly that all safety requirements are being complied with.
- ☞ Take account of the ambient conditions when installing the TCP 5000. The protection type is IP20.  
The unit is protected against the ingress of foreign bodies  $\geq \varnothing 12$  mm. Because water protection is not provided the unit must be fitted into a suitable housing (please see Section 3. Installation).
- ☞ Disconnect the plug connector on the TCP or pump only after the mains plug has been disconnected and the pump is at rest.
- ☞ When connecting the plug make sure that all mechanical locking devices are in place.
- ☞ After connecting the mains cable check for safe PE connection to the housing.
- ☞ Do not open the housing cover when the unit is connected to the mains nor during pumping operation.
- ☞ Do not carry out any unauthorised conversions or modifications on the unit.
- ☞ When returning the unit to us please note the shipping instructions (please see Section 6).

## Pictogram-Definitions



Danger of an electric shock from touching the contacts.



Danger of personal injury.









Danger of damage to the unit or system.

Modifications reserved.

### 2.1. For Your Orientation

#### Symbols Used

The following symbols are used throughout in the illustrations:

-  High vacuum flange
-  Fore-vacuum flange
-  Venting connection
-  Cooling water connection
-  Electric connection
-  Air cooling

#### Position Numbers

Identical pump and accessory parts have the same position numbers in all illustrations.

#### Operating Instruction I The Text

➔ Here, you have to do something.

### 2.2. Product Description

The Electronic Drive Unit TCP 5000 serves to drive and monitor PFEIFFER turbomolecular pumps.

The unit complies with the "Safety Ordinance For Electrical Appliances" and has been tested in accordance with the requirements of the Standard EN 61010.

The electronic drive unit contains the following functional features:

- Switching power pack
- Motor drive
- Monitoring and process control

#### Monitoring Electronics

Monitoring electronics, controlling the two relays K1 and K2, are integrated in the TCP 5000.

K1 and K2 control the pumping station and system components. The switching contacts are potential-free.

The pumping station components can be interlocked via relays K1 and K2 where the Pumping Station Control Unit TCS 130 is in operation (please see Wiring Diagram PM 021 801-S).

#### Relay K1 - switching contact "rotation speed switchpoint"

- The contact closes when the set rotation speed is attained and signalises "pump at rotation speed". The factory setting is 80% of the nominal rotation speed.
- The contact can be used, for example, to control the pump heating unit.
- Adjustment as in Section 3.8.

#### Relay K2 - switching contact "operations"

Plug pins b4 and b5 on X4.

- Relay K2 is controlled via locking relay K3. After switching on the mains voltage relay K2 switches if K3 is set.
- Adjustment as in Section 3.8.

#### Relay K3 - locking relay

During normal operations relay K3 is closed and opens in the event of a malfunction.

A malfunction is:

- Non-attainment of 80% of the nominal rotation speed within the start-up time.
- A reduction of the nominal rotation speed to below 80% after the start-up time has elapsed.
- An interruption of the operating fluid monitoring for more than 20 seconds after 50% of the final rotation speed has been attained.
- Excess rotation speed of more than 5%.

Once a malfunction has been corrected K3 must be re-set via the pressure key RESET (S3).

#### Connection Options For:

- Remote control (TCI 001)
- Pumping Station Control Unit TCS 130 with connection options for the backing pump, fore-vacuum safety valve, heating, high vacuum valve, cooling water monitor and venting valve.
- Potential-free contacts K1 "rotation speed switchpoint" and K2 "operations" for external control.

#### Stand-By Function

- The turbopump can be operated optionally at 66% (stand-by) or at the nominal rotation speed.
- The function "stand-by" is switched with key S9 on the front panel. When stand-by has been switched on, control lamp 3 illuminates (V5).
- The stand-by function is lost if there is a power failure or switching off. When the pump is switched on again, the pump operates at its nominal rotation speed.
- When the pumping station is switched off and power failure the switched status "stand-by" is maintained.
- If stand-by is switched off via pressure key S9 or S10 (see below), the pump accelerates to its nominal rotation speed and the start-up phase begins again. Rotation speed monitoring proceeds as in switching on.

#### Remote Control Stand-By

- Switch S10 between pins 1 and 15 on plug X9 (not included in the delivery) is used for remote control purposes.
- If stand-by is switched via the remote control, key S9 on the front panel has no function.

### Proper Use:

- The Electronic Drive Unit TCP 5000 may only be used to drive and monitor PFEIFFER turbomolecular pumps.
- The operations unit TCP- turbopump may only be operated together with a backing pump.
- Pumping Station Control Unit TCS 130 is necessary for controlling the backing pump and fore-vacuum safety valve.
- Instructions concerning installation, start-up, operating and maintenance must be observed.
- The unit with the article number PM 041 560-U may only be fitted in ion implantation systems of the company Varian in accordance with their instructions.
- All other uses require the prior agreement of PFEIFFER VACUUM.

### Improper Use:

Improper is:

- Uses not covered above, and, in particular,
  - Connection to pumps and units which is not permitted in their operating instructions.
  - Connection to units which contain touchable and voltage carrying parts.

Improper use will cause any rights regarding liability and guarantees to be forfeited.

## 2.3 Description Of The Front Panel

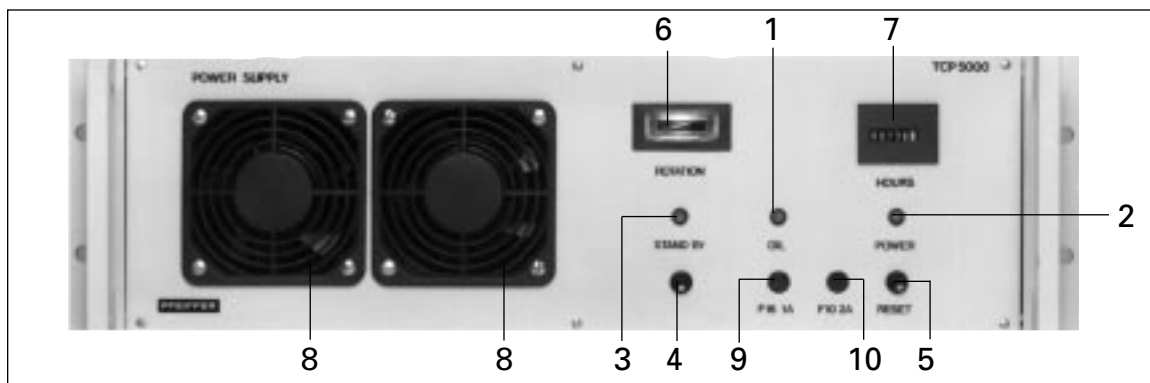

- 1 Control lamp, lubricant
- 2 Control lamp, power supply
- 3 Control lamp, stand-by
- 4 Switch S9 (stand-by)
- 5 Switch S3 (reset)

- 6 Rotation speed display
- 7 Operating hours counter
- 8 Ventilator
- 9 Fuse F16/1A
- 10 Fuse F10/2A

## 2.4 Description Of The Rear Panel

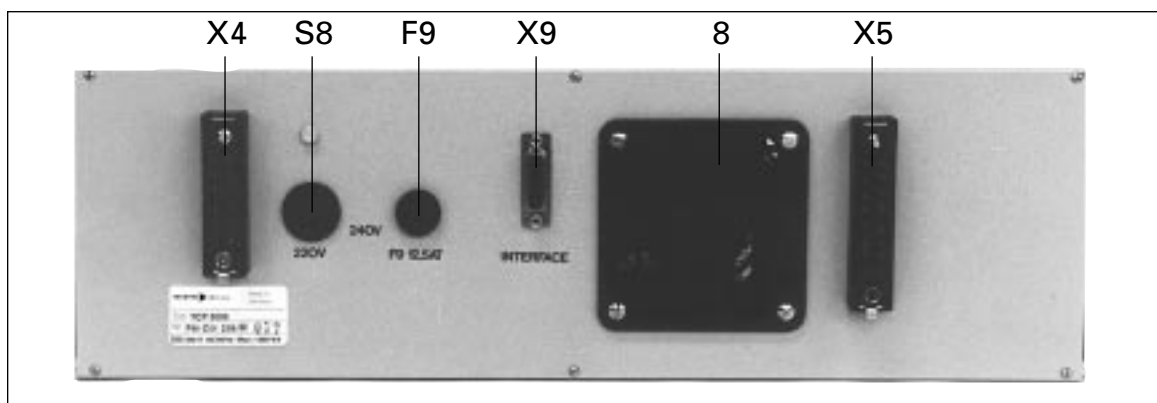

- X4 Connector plug, mains
- X5 Connector plug, pump
- X9 Connection Remote Control Monitor TCI 001 (remote control)
- S8 Voltage selector switch 220-240V
- F9 Mains fuse
- 8 Ventilator grill

# 3. Installation

## 3.1. Preparations For Installation



Unauthorised modifications or alterations to the electronic drive unit are not allowed. The unit must be fitted in a housing taking account of the ambient conditions (see Section 7, "Technical Data").

The unit has been constructed in accordance with protection type IP20.

For the reliable operating of a pumping station we recommend the use of a PFEIFFER Pumping Station Control Unit TCS 130. This includes switching and control elements for the respective pumping station components. Wiring should be carried out in accordance with the Circuit Diagram PM 021 801-S (please see Section 8).

Where the unit is to be fitted into a rack the plugs must be connected to the unit in such a way that they can only be disconnected using the appropriate tools.

➔ Disconnect mains power before installation work.

## 3.2. Fitting The Unit Into A Rack

The electronic drive unit has been designed to permit fitting in as rack. The following should be taken account of when fitting:

- The ambient temperature in the rack casing should not exceed 40°C.

## 3.3. Mains Power Connection

- Mains connection must be made in accordance with the local regulations.



Danger of an electrical shock resulting from incorrect connections.

- ➔ Connect the mains cable to X4 and connect the unit to single phase alternating current 220V/240V, 50/60Hz.
- ➔ Set the voltage selector switch S8 to the correct value.

### Operating a TCP 5000 without pumping station control unit:

- ➔ For direct connection to the mains voltage (without control unit TCS) bridge X4/a1 - b1, X4/a2 - b2.
- ➔ Use an in situ contactor  $K_x$  for switching the electronic drive unit on and off.

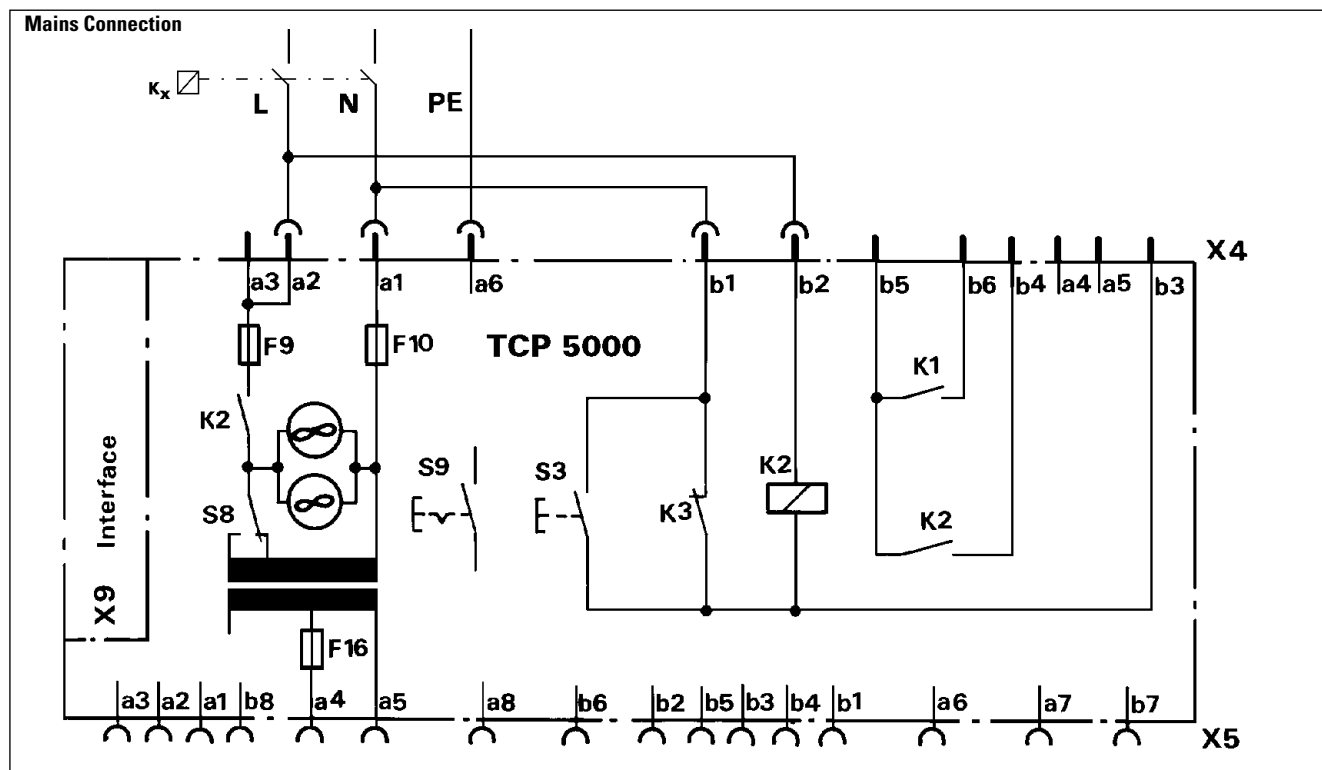

### 3.4. Connections Schematic

Connecting mains voltage without the use of Pumping Station Control Unit TCS 130.

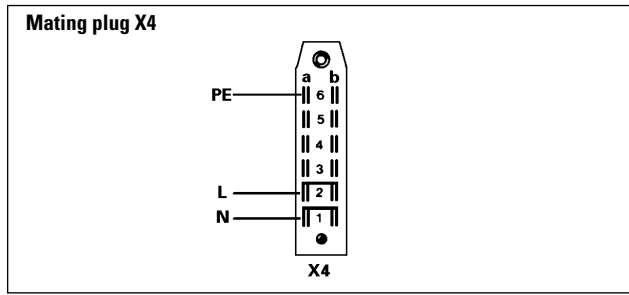

### 3.5. Connecting The Turbopump



Voltages of up to 150V can occur on the open electrical connections of a pump which is still rotating. There is a danger of an electrical shock from touching the contacts.



Only disconnect the plug connector to the electronic drive unit once the pump is completely at rest and the electronic drive unit has been disconnected from the mains power supply.

- ➔ Use a contactor as shown in the input schematic on page 6.
- ➔ Connect the turbomolecular pump (X8) with connecting cable to plug connector X5.
- ➔ Plug X5 and socket X8 must be interlocked after plugging in and unlocked before disconnecting.
- ➔ Interlock X5: Provide interlocking 16 and screw in with self-tapping screw 17.
- ➔ Interlock X8: Lightly tighten screw 18 after the bayonet lock has engaged.

### Turbopumpe anschließen

- |                 |                         |
|-----------------|-------------------------|
| 16 Interlock    | X5 Connection TCP       |
| 17 Screw        | X8 Connection turbopump |
| 18 Screw        |                         |
| 19 Bayonet lock |                         |

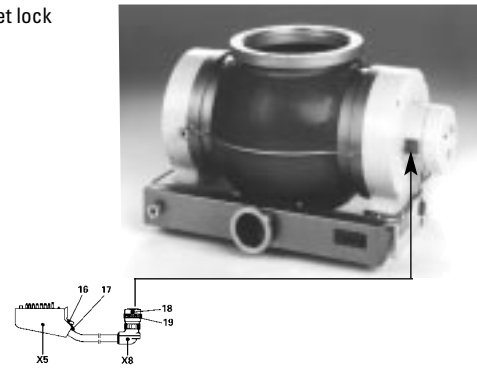

The interlocking parts are included with the delivery consignment in a separate pack.

Only PFEIFFER connecting cable should be used for connecting the pump.

### 3.6. Connecting The Pumping Station Control Unit TCS 130 (Option)



Only disconnect the plug connector to the Pumping Station Control Unit TCS 130 when the pump is completely at rest and the unit has been disconnected from the mains.

- ➔ Connect the Pumping Station Control Unit TCS 130 in accordance with the connections diagram in Section 8 and Operating Instructions PM 800 205 BN.
- ➔ Connect the TCS 130 to X4/TCP 5000.

No additional units must be connected to X4/TCP 5000. Please refer to Operating Instructions PM 800 205 BN for further information on connecting the pumping station control unit.

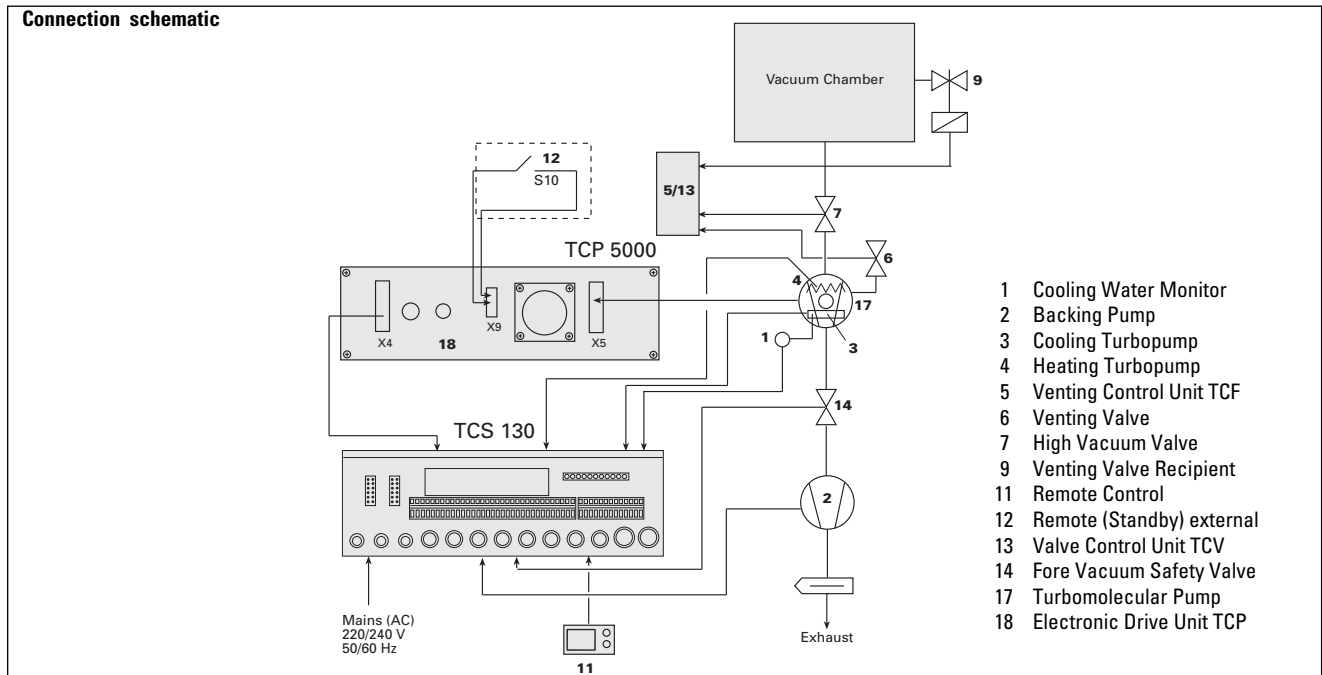

### 3.7. Connecting The Potential-Free Contacts



Where voltages of up to 250V% which are hazardous to touch are being connected the relevant installation instructions must be observed (double insulation).

- ➔ K1: plug pins b5 and b6
- ➔ K2: plug pins b4 and b5

### 3.8 The Adjustment Of The Monitoring Electronics For Exceptional Applications

#### Rotation speed switchpoint (relay K1)

The switchpoint for the rotation speed of the turbopump has been set in the factory to 80% of the nominal rotation speed and can be altered to between 70% and 90% via trimming potentiometer R56/Control Print PM 041 271-X.

#### Start-up time (relay K2)

During the start-up time the pump rotor is accelerated to rotation speed after which the rotation speed is monitored.

- ➔ Set the start-up time for switching contact K2 with potentiometer R90.

Setting range: TPH/TPU 2200 from 1 – 45 min  
 TPH 5000 from 3 min – 120 min.

longer

shorter

- For the TPH/TPU 2200 and the TPH 5000 the factory settings are approximately 20 minutes and 60 minutes respectively.
- By bridging X4/a4-a5 the unit can be prevented from switching off in the event the rotation speed falls below the switchpoint.

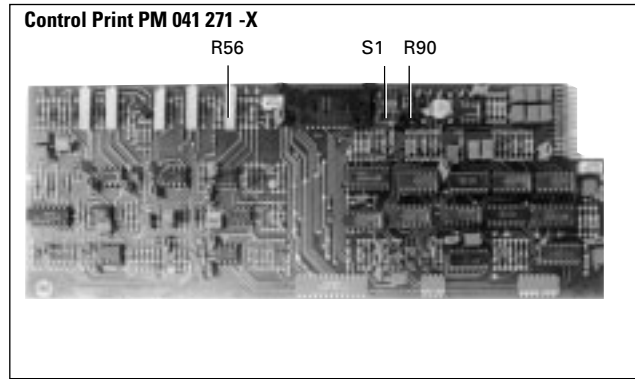

R56	80% rotation speed switchpoint	higher
		lower
R90	Start up phase	longer
		shorter
	TPH/TPU 2200: 1 – 45 min	
	TPH 5000: 3 – 120 min	
S1	DIL switch	

#### Function Of The DIL Switch S1

##### S1 open:

The rotation speed is monitored after the start-up time has elapsed (K2 opens when the rotation speed switchpoint is fallen below or non-attained).

##### S1 closed:

The rotation speed is monitored immediately the rotation speed switchpoint (DZP) is exceeded (K2 opens when the DZP is fallen below). When the rotation speed switchpoint is fallen below, even within the set start-up time, the electronic drive unit is switched off immediately.



On delivery, switch S1 on the TCP 5000 is open.

### 3.9. Operating The Electronic Drive Unit TCP 5000 With Accessories

#### Control Units

The Electronic Drive Unit TCP 5000 can be operated with Pumping Station Control Unit TCS 130. A Venting Control Unit TCF 103 or a Valve Control Unit TCX 103 can be integrated in the TCS 130.

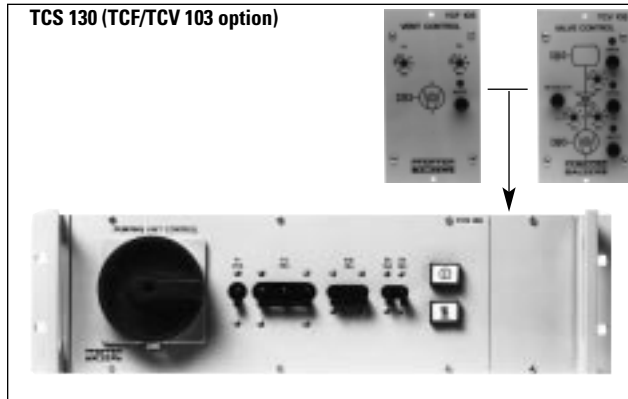

- ➔ Connect the TCP to TCS 130/X4.

## 4. Operations

### 4.1 Switching ON The Electronic Drive Unit

- ➔ Make the connection TCP - turbopump in accordance with Section 3.5.
- ➔ Make the cooling water connection turbopump.
- ➔ Switch the TCP into the mains via contactor  $K_x$ .

Providing the electrical connections have been carried out in accordance with Wiring Diagram PM 021 801-S, the control contains optimum interlocking. Components can be selected depending on the application.

#### Switching ON Via Pumping Station Control Unit TCS 130

- ➔ Switch on main switch S7.
- ➔ Switch on the pumping station with S1.
- ➔ Switch on any possible heating with S2.

### 4.2 Start-Up, Turbopump

After switching on, the turbopump begins to run. Operating fluid monitoring becomes active when 50% of the final rotation speed is attained. If the flow of operating fluid is interrupted for more than 20 seconds the turbopump is switched off.



When a turbopump is operated for the very first time bubbles can form in the operating fluid feeder line and this can cause the turbopump to be switched off owing to a lack of operating fluid.

#### Controller

The following operating functions can be displayed if Controller TCI 001 is in use:

- Lubricant insufficiency
- Pump temperature too high
- TCP temperature too high
- TCP switched on
- Pump accelerates
- The pump rotation speed < nominal rotation speed
- The pump rotation speed < nominal rotation speed switch-point
- The pump rotation speed = nominal rotation speed
- Stand-by

- ➔ Connect the TCI 001 to plug X9 via the connecting cable. The TCI is designed to provide remote displays.



Only safety low voltages (SELV) may be connected to the serial interface plug.

The electrical connections must be carried out in accordance with Operating Instructions PM 800 107 BE for the TCI 001.

- ➔ In the event of a malfunction re-start with RESET, ensuring that the electronic drive unit is supplied with voltage and that the reset key is depressed for at least 5 seconds.

If a TPH 5000 is in use, the start-up current is 10A. When the nominal rotation speed is attained the current reduces to approximately 5A and can increase, depending on the gas load, to 10A. The start-up current is 5A where pumps with a rotation speed of 600 Hz (TPH/TPU 2200/1600) are involved.

### 4.3. Operations At Nominal Rotation Speed

When 95% nominal rotation speed is exceeded the maximum current is reduced to 3A to prevent the pump rotor from overheating from too high a gas load (not applicable on the TPH 5000).

### 4.4. Stand-By Operations

Stand-by operations are recommended where high gas loads or process interruptions are involved. In this case the rotation speed is reduced and the current is maximum 5A. The danger of rotor overheating does not arise owing to the slower circulation speeds of the rotor blades.

### 4.5 Switching OFF

The switching off procedure is as follows:

- ➔ Switch off the heating and allow the pump to cool.
- ➔ Close the high vacuum valve (if provided).
- ➔ Switch off the pumping station.
- ➔ Vent the pumping station with the venting control unit (automatic) or manually.

## 5. What To Do In The Case Of Breakdowns ?

There are a number of possibilities to eliminate malfunctions:

- ➔ If the pump does not start after being switched on, depress the RESET key for at least 5 seconds.
- ➔ Check the malfunction display on a connected TCI 001.

The following malfunctions cause a drop-out of relays K3 and K2. They can be acknowledged by depressing RESET (S3) when the malfunction has been eliminated:

- Lubricant insufficiency, turbopump
- Motor rotation speed > 105% nominal rotation speed
- Rotation speed falls below switchpoint K1.
  
- Cooling water insufficiency\*
- Backing pump(s) breakdown\*
- Automatic circuit breakers breakdown F1, F5 or F15.\*

\* Only in connection with the TCS 130.

### Pressure key RESET

- Relay K3 is a locking relay.
- During normal operations K3 is closed and opens in the event of a malfunction.
- Mains voltage must be present on the electronic drive unit for K3 to close.

- ➔ Close relay K3 with the RESET key. Depress for at least 5 seconds.



The TCP 5000 is not potential-free. When the pump is running down the drive motor acts a generator and generates up to 200 V DC.

- ➔ Release the interlocking on plug connections X5 and X4 only when the pump is completely at rest.
- ➔ Disconnect plug connection X4 only when the pump is completely at rest.

## 6. Maintenance, Service

The unit is maintenance-free. Dirt on the front panel can be removed with a damp cloth having first disconnected the unit from the mains power supply.

### Do Make Use Of Our Service Facilities

In the event that repairs are necessary a number of options are available to you to ensure any system down time is kept to a minimum:

- Have the pump repaired on the spot by our PFEIFFER Service Engineers;
- Return the pump to the manufacturer for repairs;
- Replace the unit with an as good as new exchange unit.

Local PFEIFFER representatives can provide full information.

The connections diagram in Section 10 shows the power carrying current paths.



Customers who carry out their own repairs must take account of the possibility that touchable dangerous voltages can be present in the unit.

### Please Note:

Repair orders are carried out according to our general conditions of sale and supply. If repairs are necessary, please send the pump to your nearest PFEIFFER Service Center.

### Contact Addresses And Telephone Hotline

Contact addresses and telephone numbers can be found on the back cover of these operating instructions.

## 7. Technical Data

### 7.1. Data List Electronic Drive Unit TCP 5000

Turbopump		TPH 5000	TPH/U 1600 TPH/U 2200
Connection voltage:	V AC	220 - 240	220 - 240
Current:	A	12	12
Power take-up	VA	2400	2400
Frequency:	Hz	50-60	50-60
Output voltage, motor connection:	V=	200	200
Output current motor connection:	A	10	5
Power loss:	Watt	?	
permissible ambient temperature:	°C	5 - 40	5 - 40
Maximum relative humidity	% ( at 35 °C)	80	80
"	% at 40 °C)	50	50
Protection type:		IP 20	IP 20
Protection class:		1	1
<b>Potentialfree Contacts</b>			
permissible voltage:	V AC	220	220
Current with ohmic load K1:	A	8	8
K2:	A	2	2
Start-up time, adjustable to:	min	120	45
Rotation speed switchpoint:	%	70-90	70-90
Maximum cable length:	m	100	100

### 7.2. Dimensions

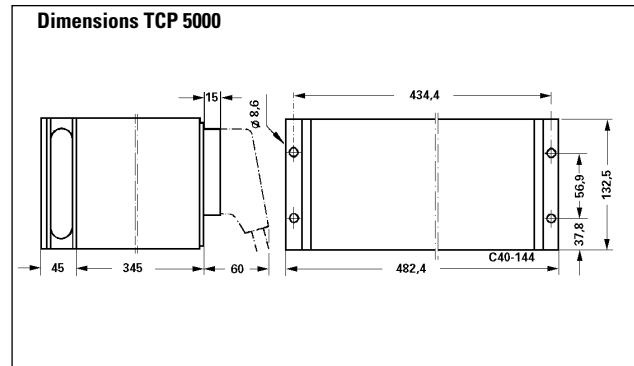

# 8. Connections Diagram

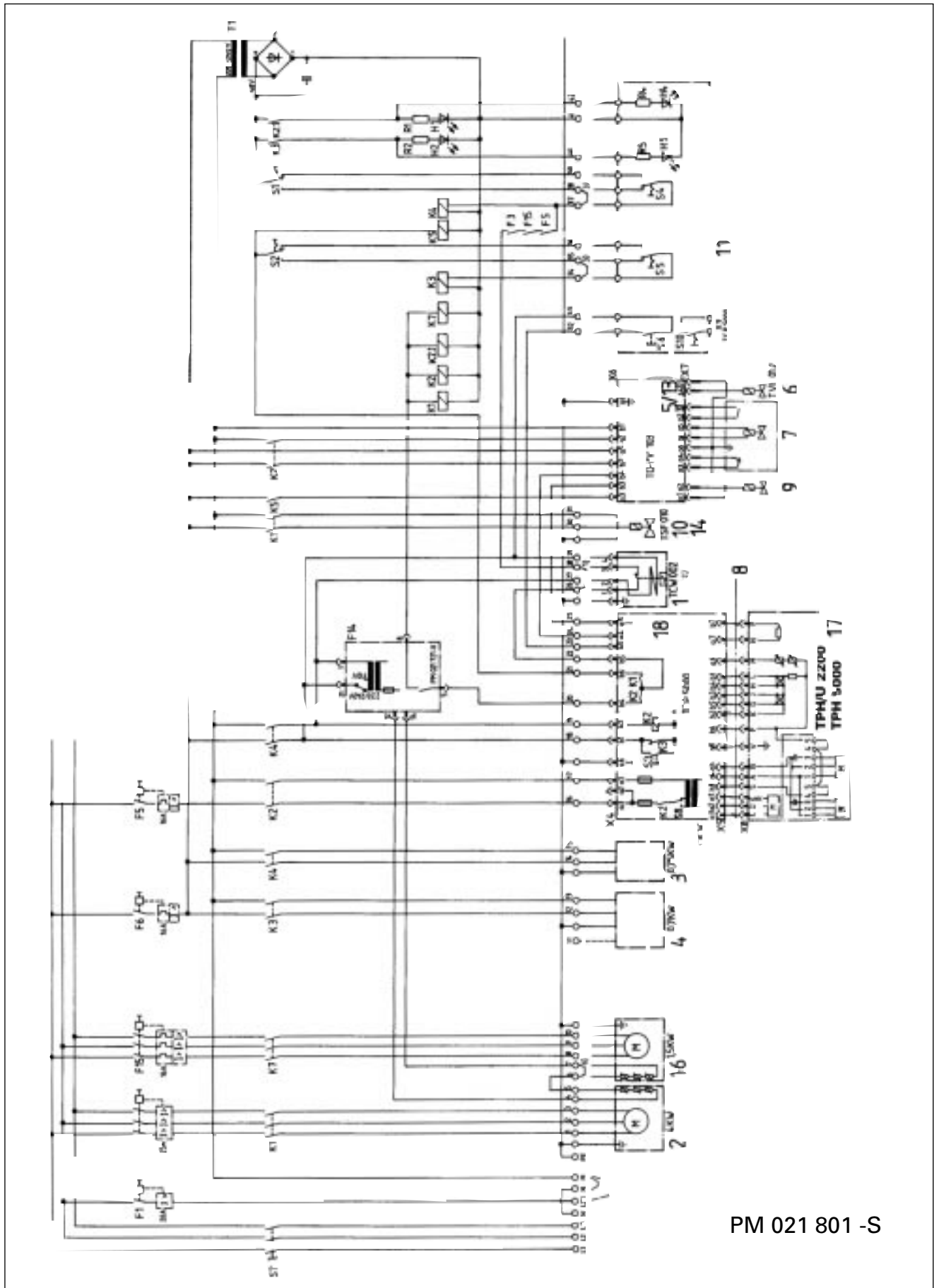

PM 021 801 -S

## 9. Accessories

When ordering spare parts please state the full article description and number. Keep a copy of this page as a record of your order.

Description	Size	Number	Operating Instructions	Order Quantity/ Comments
Pumping Station Control Unit TCS 130	208- 240 V; 50/60 Hz	PM C01 551	PM 800 205 BN	(other lengths on request)
Connecting cable turbopump – TCP	3 m	PM 011 232 -X		
Mains cable Schuko		PM 041 400 -X		
	208 V	PM 041 401 -X		
Serial Interface TCI 001		PM C01 291	PM 800 107 BN	
Serial Interface cable	0,5 m	PM 011 462 -X		
Serial Interface cable	3 m	PM 011 463 -X		
Fore vacuum safety valve TVV 001	230 V	PM Z01 205	PM 800 263 BN	

### Wiring Diagram Legend

- 1 Cooling Water Monitor TCW
- 2 Rotary Vane Vacuum Pump
- 3 Air Cooling or Cooling Aggregate TZK
- 4 Heating Turbopump
- 5 Venting Control Unit TCF
- 6 Venting Valve TVF
- 7 High Vacuum Valve
- 8 Cable TCP-turbopump
- 9 Venting Valve vacuum chamber
- 10 Power failure Venting Unit TSF
- 11 Remote control
- 12 STAND-BY external
- 13 Valve Control Unit TCV
- 14 Fore-vacuum valve
- 16 Roots Vacuum Pump WKP
- 17 Turbopump
- 18 Electronic drive unit
- H1 Pumping Station ON
- H2 Heating ON
- H4 Pumping Station ON (in remote control mode)
- H5 Heating ON (in remote control mode)
- S1 Pumping station
- S2 Heating
- S3 Reset
- S4 Pumping Station (in remote control mode)
- S5 Heating (in remote control mode)
- S6 Reset (in remote control mode)
- S7 Main switch TCS
- S8 Voltage selector switch TCP
- S9 Stand-by, TCP
- S10 Stand-by external
- 1) Remove bridge when a TCW is connected
- 2) 1-3 closed at a room temperature of <24°C
- 3) Remove bridge when operating remote control
- 6) Remove bridge when a WKP is connected

## ⇒ DE, AT

**Herstellererklärung im Sinne folgender EU-Richtlinien:**

- Maschinen 89/392/EWG
- Elektromagnetische Verträglichkeit 89/336/EWG
- Niederspannung 73/23/EWG

Hiermit erklären wir, daß das unten aufgeführte Produkt zum Einbau in eine Maschine bestimmt ist und daß deren Inbetriebnahme so lange untersagt ist, bis festgestellt wurde, daß das Endprodukt den Bestimmungen der EU-Richtlinie 89/392/EWG, Anhang II B entspricht.

Wir bestätigen Konformität mit der EU-Niederspannungsrichtlinie 73/23/EWG. Bei der Baumusterprüfung wurde mit Zusatzausrüstung Konformität mit der EU-Richtlinie über elektromagnetische Verträglichkeit 89/392/EWG festgestellt, die auch bei Einhaltung der Installationsvorschriften erreicht wird. Die angewandten Richtlinien, harmonisierten Normen, nationalen Normen und Spezifikationen sind unten aufgeführt.

## ⇒ GB, IE

**Manufacturer's declaration pursuant to the following EU directives:**

- Machinery Directive 89/392/EEC
- Electromagnetic Compatibility Directive 89/336/EEC
- Low Voltage Directive 73/23/EEC

We hereby certify that the product specified below is intended for installation in a machine which is forbidden to be put into operation until such time as it has been determined that the end product is in accordance with the provision of EU Directive 89/392/EEC, Annex II B.

We certify conformity with EU Low Voltage Directive 73/23/EEC. During a certifying test with additional equipment conformity with the EU-directive relating to EMI 89/392/EEC was found. This will be reached too if the installation instructions are followed. The guidelines, harmonised standards, national standards and specifications which have been applied are listed below.

## ⇒ BE, FR

**Déclaration du constructeur conformément aux directives CE suivantes:**

- directive machine CE 89/392/CEE
- directive CE 89/336/CEE concernant la compatibilité électromagnétique
- directive CE 73/23/CEE concernant la basse tension

Nous déclarons par la présente que le produit mentionné ci-dessous est prévu pour le montage sur une machine et que sa mise en service est interdite tant qu'il n'a pas été déterminé que le produit final répond bien aux dispositions de la directive CE 89/392/CEE, appendice II B.

Nous confirmons la conformité du produit avec la directive CE 73/23/CEE concernant la basse tension. La conformité requise avec la directive UE régissant la compatibilité électromagnétique 89/392/CE, qui est également obtenue en observant les directives en matière d'installation, a été constatée lors du processus d'homologation réalisé avec un équipement complémentaire. Les directives appliquées, normes harmonisées et les normes et spécifications nationales appliquées figurent ci-dessous.

## ⇒ IT

**Dichiarazione del costruttore ai sensi delle seguenti direttive UE:**

- Macchinari 89/392/CEE
- Compatibilità elettromagnetica 89/336/CEE
- Bassa tensione 73/23/CEE

Si dichiara che il prodotto qui menzionato è destinato al montaggio in una macchina e che la sua messa in funzione è vietata sin quando non è stato accertato che il prodotto finale non rispetta le disposizioni della direttiva UE 89/392/CEE, Appendice II B.

Attestiamo la conformità con la direttiva UE sulla bassa tensione 73/23/CEE. Durante la prova di omologazione è stata accertata, con equipaggiamento supplementare, la conformità con la direttiva UE relativa alla compatibilità elettromagnetica 89/392/CEE, che si ottiene anche nell'osservanza delle norme di installazione. Sono riportate in basso le direttive applicate, le norme standardizzate nonché le norme e le specifiche nazionali utilizzate.

## ⇒ ES

**Declaración del fabricante al tenor de las siguientes Directivas de la UE:**

- Maquinarias 89/392/MCE
- Compatibilidad Electromagnética 89/336/MCE
- Baja Tensión 73/23/MCE

Por la presente declaramos que el producto mencionado más abajo está previsto para ser incorporado en una máquina y que la puesta en servicio de la misma queda prohibida en tanto que no se haya verificado que el producto final concuerda con las disposiciones resultantes de la Directiva 89/392/MCE de la UE, Apéndice II B.

De nuestra parte certificamos la conformidad con la Directiva 73/23/MCE de la UE sobre Baja Tensión. En la comprobación del modelo de construcción, se ha constatado con equipamiento adicional la conformidad con la directiva de la UE sobre compatibilidad electromagnética 89/392/MCE, que se consigue también cumpliendo las prescripciones de instalación. Las directivas aplicadas, normas armonizadas y las normas y especificaciones nacionales aplicadas se mencionan abajo.

## ⇒ NL

**Verklaring van de fabrikant in de zin van de volgende EU-richtlijnen:**

- machinerichtlijn 89/392/EEG
- richtlijn over elektromagnetische compatibiliteit 89/336/EEG
- richtlijn over laagspanning 73/23/EEG

Hiermee verklaren wij dat het hieronder genoemde produkt is bedoeld om te worden ingebouwd in een machine en dat de ingebruikneming hiervan zolang verboden is, totdat is vastgesteld dat het eindprodukt voldoet aan de bepalingen van EU-richtlijn 89/392/EEG, appendix II B.

Wij bevestigen de conformiteit met de EEG-richtlijn over laagspanning 73/23/EEG. Bij de bouwtypekeuring is met aanvullende uitrusting conformiteit vastgesteld met de EU-richtlijn over elektromagnetische compatibiliteit 89/392/EEG, die ook wordt bereikt bij het in acht nemen van de installatievoorschriften. De toegepaste richtlijnen, geharmoniseerde normen en de toegepaste nationale normen en specificaties zijn hierna aangegeven.

## ⇒ DK

**Producenterklæring i henhold til følgende EU-direktiver:**

- Maskiner 89/392/EWG
- Elektromagnetisk kompatibilitet 89/336/EWG
- Lavspænding 73/23/EWG

Herved erklærer vi, at det nedenstående produkt er beregnet til indbygning i en maskine og at dennes idriftsættelse er forbudt, indtil det er fastslået, at slutproduktet er i overensstemmelse med EU-direktiv 89/392/EWG tillæg II B.

Vi attesterer konformitet med EU-lavspændingsdirektiv 73/23/EWG. Ved konstruktionsprøvekontrollen er der med ekstra udstyr blevet fastslået konformitet med EU-direktivet vedrørende elektromagnetisk kompatibilitet 89/392/EWG, hvad der også kan opnås ved overholdelse af installationsforskrifterne. De anvendte direktiver, harmoniserede standarder og de anvendte nationale standarder og specifikationer er angivet nedenfor.

## Tillverkarens förklaring enligt följande EG-direktiv:

- Maskindirektiv 89/392/EEC

- Elektromagnetisk tolerans 89/336/EEC

- Lågspänning 73/23/EEC

Härmed förklarar vi, att den nedan nämnda produkten är avsedd för inmontering i en maskin och att denna maskin inte får tas i drift förrän det har konstaterats, att slutprodukten stämmer överens med EG's direktiv 89/392/EEC, annex II B.

Vi bekräftar konformitet med EG's lågspänningsdirektiv 73/23/EEC. I samband med typprovningen fastställdes också med extra utrustning konformitet med EU-direktivet om elmagnetisk tolerans 89/392/EEC, som även uppnås om installationsföreskrifterna beaktas.

De riktlinjer, anpassade standarder, nationella standarder och specifikationer som har blivit accepterade, anges här nedan.



### Valmistajan vakuutus seuraavien EU-direktiivien mukaisesti:

- konedirektiivi 89/392/ETY

- sähkömagneettinen siedettävyyys 89/336/ETY

- pienjännite 73/23/ETY

Vakuutamme täten, että allamainittu tuote on tarkoitettu asennettavaksi koneeseen ja sen käyttöönotto on kielletty kunnes on todettu, että lopullinen tuote vastaa EU-direktiivin 89/392/ETY vaatimuksia.

Vahvistamme vaatimustenmukaisuuden EU-pienjännitedirektiivin 73/23/ETY kanssa. Rakennemallitarkastuksessa todettiin lisävarustuksella vaatimustenmukaisuus sähkömagneettisesta yhteensopivuudesta annetun EU-direktiivin 89/392/ETY kanssa, joka saavutetaan myös asennusmääräyksiä noudattamalla.

Soveltamamme suuntaviitat, harmonisoidut standardit, kansalliset standardit ja rakennemääräykset on luteltu alempana.



### Declaração do fabricante, de acordo com as seguintes Directivas CE:

- Máquinas, na redacção 89/392/CEE

- Compatibilidade electromagnética, na redacção 89/336/CEE

- Baixa tensão, na redacção 73/23/CEE

Com a presente, declaramos que o produto abaixo indicado se destina à montagem numa máquina e que é proibida a colocação em serviço da mesma antes de se ter declarado, que o produto final está em conformidade com o disposto na Directiva CE, na redacção 89/392/CEE, Apêndice II B.

Certificamos haver conformidade com o disposto na Directiva CE sobre baixa tensão, na redacção 73/23/CEE. Ao fazer-se o exame do tipo de construção, com um equipamento adicional constatou-se existir conformidade com a directriz CE sobre a compatibilidade electromagnética 89/392/CEE, a qual também se consegue, mantendo-se as disposições referentes à instalação.

Abaixo, dá-se indicação das directivas aplicadas, das normas harmonizadas e das normas e especificações aplicadas no respectivo país.



Δήλωση κατασκευαστή κατά το νόημα των εθνικών οδηγιών της Ε.Ε.:

- περί μηχανών 89/392/Ε.Ο.Κ.

- περί ηλεκτρομαγνητικής συμβατότητας 89/336/Ε.Ο.Κ.

- περί χαμηλής τάσης 73/23/Ε.Ο.Κ.

Με την παρούσα δήλωση βεβαιώνουμε ότι το κατωτέρω αναφερόμενο προϊόν προορίζεται για την προσαρμογή σε μία άλλη μηχανή, και ότι η έναρξη λειτουργίας της απαγορεύεται μέχρις ότου διαπιστωθεί, ότι το συνολικό συγκρότημα ανταποκρίνεται στους ισχύοντες κανονισμούς της οδηγίας της Ε.Ε. 89/392/Ε.Ο.Κ., παράρτημα II Β.

Κατά τον δοκιμαστικό έλεγχο της κατασκευαστικής ομάδας με βοηθητικό εξοπλισμό, διαπιστώθηκε η ανταπόκριση με την Οδηγία της Ε.Ε. 89/392/Ε.Ο.Κ.

σχετικά με την ηλεκτρομαγνητική συμβατότητα, η οποία εκπληρώνει και τους κανονισμούς εγκατάστασης.

Οι εφαρμοσθέντες κανονισμοί, οι εναρμονισμένες προδιαγραφές και οι εφαρμοσθείσες εθνικές προδιαγραφές και τεχνικές προδιαγραφές αναφέρονται κατωτέρω:

Produkt/Product/Produit/Prodotto/Producto/Produkt/Produkt/Produto/ Προϊόν:

## TCP 5000

Angewendete Richtlinien, harmonisierte Normen und angewendete, nationale Normen in Sprachen und Spezifikationen:

Guidelines, harmonised standards, national standards in languages and specifications which have been applied:

Les directives appliquées, normes harmonisées et les normes nationales appliquées en langues et spécifications:

Directive applicate, norme standardizzate e norme nazionali utilizzate in lingue e specifiche:

Directivas aplicadas, normas armonizadas y normas nacionales aplicadas en idiomas y especificaciones:

Toegepaste richtlijnen, geharmoniseerde normen en toegepaste nationale normen met betrekking tot talen en specificaties:

Anvendte direktiver, harmoniserede standarder og de anvendte nationale standarder med sprog og specifikationer:

Directivas aplicadas, normas harmonizadas e normas aplicadas na linguagem e nas especificações do respectivo país:

Εφαρμοσθέντες κανονισμοί, εναρμονισμένες προδιαγραφές και εφαρμοσθείσες εθνικές προδιαγραφές σε γλώσσες και τεχνικές προδιαγραφές:

## EN 61010

Unterschriften/Signatures/Signature/Firme/Firmas/Handtekening/Underskrifter/Assinaturas/ Υπογραφές:

Geschäftsführer (W. Dondorf)

Managing Director

Gerente

Administrerende Direktør

Gerente

Gérant d'affaires

Directeur

Verkställande Direktör

Underskrift

Alllekirjoitukset

Διευθύνων Σύμβουλος

**Zentrale/Headquarters**

Pfeiffer Vacuum GmbH

Emmeliusstrasse 33  
D-35614 Asslar

Telefon 06441/802-0

Telefax 06441/802-202

Hotline 06441/802-333

Internet:

<http://www.pfeiffer-vacuum.de>**Argentina**ARO S.A., Casilla de Correo 4890,  
1000 Buenos Aires, telephone 0054 / 1 331 3918,  
telefax 0054 / 1 331 3572**Australia**Balzers Australia Pty. Ltd., Level 1,  
3, Northcliff Street, Milsons Point, NSW 2061,  
telephone 0061 / 2 9954 1925, telefax 0061 / 2 9954 1939**Austria**Pfeiffer Vacuum Austria GmbH  
Diefenbachgasse 35, A-1150 Wien,  
telephone 0043 / 1 8941 704, telefax 0043 / 1 8941 707  
Service Hotline: 0043 / 1 8941704**Belgium / Luxemburg**Pfeiffer Vacuum Belgium N.V./S.A.  
Minervastraat 14, B-1930 Zaventem  
telephone 0032 / 2 725 0525, telefax 0032 / 2 725 0873  
Service Hotline: 0032 / 2 725 3545**Brazil**Elmi Tec  
Assistencia Técnica e Representação S/C Ltda.  
Rua Bernadino de Compos, 551  
CEP 04620-002 São Paulo, SP - Brasil  
telephone 0055 / 11 532 0740  
telefax 0055 / 11 535 3598**Chile**BERMAT S.A., Coyuncura 2283, piso 6  
Providencia, P.O. Box 9781, Santiago  
telephone 0056 / 2 231 8877,  
telefax 0056 / 2 231 4294**Colombia**Arotec Colombiana S.A., Carrera 15 No.38-17  
P.O. Box 050 862, Santafe de Bogota / D.C.  
telephone 0057 / 1 288 7799, telefax 0057 / 1 285 3604**Denmark**Pfeiffer Vacuum Scandinavia AB, Vesterengen 2,  
DK-2630 Taastrup, telephone 0045 / 43 52 38 00,  
telefax 0045 / 43 52 38 50**France**Pfeiffer Vacuum France SAS  
45, rue Senouque, BP 139 F-78531 BUC Cedex  
telephone 0033 / (0)1 30 83 04 00,  
telefax 0033 / (0)1 30 83 04 04**Germany**Pfeiffer Vacuum Vertriebs GmbH,  
Emmeliusstrasse 33, D-35614 Asslar  
telephone 0049 / 6441 802 400  
telefax 0049 / 6441 802 399  
Service Hotline: 0049 / 6441 802 333**Great Britain**Pfeiffer Vacuum Ltd.  
Bradbourne Drive, Tilbrook,  
Milton Keynes, MK7 8AZ, United Kingdom  
telephone 0044 / 1 908 373 333  
telefax 0044 / 1 908 377 776**Greece**Analytical Instruments S.A., 1 Mantzarou St.,  
GR-15451 Athens,  
telephone 0030 / 1 674 8973, telefax 0030 / 1 674 8978**India**Pfeiffer Vacuum India Ltd.  
25-E Nicholson Road, Tarbund  
Secunderabad 500 009,  
telephone 0091 / 40 775 0014, telefax 0091 / 40 775 7774**Israel**Eastronics Ltd., 11 Rozanis Street, P.O. Box 39 300,  
Tel Aviv 61392,  
telephone 00972 / 3 6458 777,  
telefax 00972 / 3 6458 666**Italy**Pfeiffer Vacuum Italia S.p.a.  
Via San Martino, 44 I-20017 RHO (Milano)  
telephone 0039 / 2 93 99 051, telefax 0039 / 2 93 99 05 33**Japan**Hakuto Co. Ltd., C.P.O. Box 25,  
Vacuum & Scientific Instruments Division  
Tokyo Central 100-91,  
telephone 0081 / 3 32 258 910,  
telefax 0081 / 3 32 259 009**Korea**Pfeiffer Vacuum Korea Ltd., 3F Haein Building 453,  
Dokok-Dong, Kang Nam-Ku, Seoul, 135-270  
telephone 0082 / 2 3461 0671,  
telefax 0082 / 2 3461 0676**Netherlands**Pfeiffer Vacuum Nederland BV  
Veldzigt 30a, NL-3454 PW De Meern,  
telephone 0031 / 30 6666050, telefax 0031 / 30 6662794**Peru**Ing. E. Brammertz S.C.R.L., José Pardo 182,  
Apartado 173, PE-18 Miraflores,  
telephone 0051 / 1 445 8178  
telefax 0051 / 1 445-1931**Poland**Softrade Sp.z.o.o, ul. Malwowa 35,  
PL-60-175 Poznan, telephone 0048 / 61 8677 168,  
telefax 0048 / 61 8677 111**Portugal**Unilaser Lda, Taguspark  
Núcleo Central, sala n° 268, Estrada Cacém-  
Porto Salvo, P-2780 Oeiras  
telephone 00351 / 1 421 7733,  
telefax 00351 / 1 421 7744**Singapore**APP Systems Services Pte. Ltd, 2 Corporation Road  
06-14 Corporation Place, Singapore 618494,  
telephone 0065 / 268 2024, telefax 0065 / 268 6621**Spain**Tecnovac  
Tecnología de Vacío S.L., Ronda de Poniente, 6 Bajo F  
Centro Empresarial Euronova  
E-28760 Tres Cantos (Madrid)  
telephone 0034 / 91 804 11 34,  
telefax 0034 / 91 804 30 91**Sweden**Pfeiffer Vacuum Scandinavia AB  
Magasinsgatan 35, Box 10412  
S-43424 Kungsbacka  
telephone 0046 / 300 710 80  
telefax 0046 / 300 172 85  
Service Hotline: 0046 / 300 710 85**Switzerland**Pfeiffer Vacuum Schweiz S.A.  
Förrlibuckstraße 30, CH-8005 Zürich  
telephone 0041 / 1 444 2255,  
telefax 0041 / 1 444 2266  
Service Hotline: 0041 / 1 2730119**South Africa**Labotec Pty Ltd., P.O. Box 6553,  
Halfway House  
1685 Midrand  
telephone 0027 / 11 315 5434  
telefax 0027 / 11 315 5882**Taiwan**S & T Hitech Ltd. Hsinchu office  
No. 103, Hsien Chen 11th Street, Jubei City,  
HsinChu County, Taiwan, R.O.C.  
(zip/postal code: 302)  
telephone 00886 / 3 554 1020  
telefax 00886 / 3 554 0867**Thailand**S & T Enterprises (Thailand) Ltd.  
18th Floor, Chokchail Int'l Bldg.  
690 Sukhumvit Road  
Klongton, Klongtoey  
Bangkok 10110  
telephone 00662 / 259 4623  
telefax 00662 / 259 6243**U.S.A.**Pfeiffer Vacuum, Inc.  
24 Trafalgar Square  
Nashua, NH 03063-1988  
USA  
telephon 001/ 603 578 6500  
telefax 001/ 603 578 6550**Venezuela**Secotec S.A., Apartado 3452, Caracas 1010-A,  
telephone 0058 / 2 573 8687  
telefax 0058 / 2 573 1932**Other countries**AVI - Applied Vacuum Industries GmbH  
Leginglenstrasse 17A; CH-7320 Sargans  
Switzerland  
telephon 0041 / 81 710 03 80  
telefax 0041 81 710 03 81**Scope of represented countries**Armenia, Azerbaijan, Bangladesh, Belarus, Bulgaria,  
Cambodia, Estonia, Georgia, Hong Kong, Kazakhstan,  
Kingdom of Nepal, Kirghizia, Latvia, Lithuania, Maldives,  
Philippines, P.R. China, Rumania, Russia, Tajikistan,  
Turkmenistan, Ukraine, Uzbekistan, Vietnam**A.E.M.S.**Advanced Equipment Materials and Systems  
P.O. Box 25  
Föhrenweg 18  
FL-9496 Balzers  
telephon 0041 / 75 380 0550  
telefax 0041 / 75 380 0551**Scope of represented countries**Bahrain, Egypt, Iraq, Iran, Jordan, Kuwait, Lebanon,  
Lybia, Oman, Pakistan, Saudi-Arabia, Sudan, Syria,  
Turkey, United Arab Emirates, Yemen