

7.3.2 Interlocking the STP Pump Operation with Baking

Follow the steps below to interlock the STP pump operation with baking (read through Section 8. "Remote Input/Output Signal Terminal Blocks." then start operation).



- ◇ Check the rated voltage of the baking heater before use.
- ◇ When connecting the power for the baking heater (over 25 V AC) to the remote terminal block, secure the cable using the attached cable fitting tool.
DO NOT apply excessive force to the cable for the baking heater.

<MANUAL OPERATION>

(See Section 8.1, "I/O TB2 Terminal Block.")

- i. Connect the power cable of the baking heater between "I/O TB2 HEATER OUT Terminals ① – ②."
- ii. Input the power supply of the baking heater between "I/O TB2 AC. POWER IN Terminals ⑱ – ⑳."
- iii. Press the HEATING ON/OFF switch (an alternate type) under the NORMAL OPERATION state (the HEATING ON/OFF switch built-in green lamp lights. The heater is "ON" while the lamp is being lit).
- iv. Press the HEATING ON/OFF switch under any state other than the NORMAL OPERATION. The HEATING ON/OFF switch built-in green lamp lights and the baking heater functions under the NORMAL OPERATION state.

<REMOTE OPERATION>

(See Sections 8.1 and 8.2, "I/O TB2 Terminal Block" and "DC I/O TB3 Terminal Block.")

- i. Perform the same steps (i, ii) as for the MANUAL OPERATION.
- ii. Short the circuit between "I/O TB3 HEATING Terminals ② - ④" (the HEATING ON/OFF switch built-in green lamp lights. The heater is "ON" while the lamp is being lit).
- iii. Short the circuit between "I/O TB3 HEATING Terminals ② - ④" under any state other than the NORMAL OPERATION state. The HEATING ON/OFF switch built-in green lamp lights and the baking heater functions under the NORMAL OPERATION state.

NOTICE

- ◇ The baking heater functions only while the STP pump is under the NORMAL OPERATION state.

Section 8 Remote Input/Output Signal Terminal Blocks

8.1 I/O TB2 Terminal Block

This is a terminal block for a remote output signal. Use it in accordance with Table 8.1 and Figure 8.1. The terminal block functions in both the MANUAL and REMOTE operations. The screw for the terminal is M3^{*1}.

Five abbreviations are used in the following tables:

N.O :Normal Open N.C :Normal Close COM :Common
 IN :Input Terminal OUT : Output Terminal



- ◇ When connecting optional power (over 25 V AC or over 60 V DC) to terminals ① to ⑥, ⑱ and ⑳, secure the remote cable using the attached cable fitting tool (see Figure 8.3).
DO NOT apply excessive force to the remote cable.

Table 8.1 I/O TB2 Terminal Block (1/2)

Terminal	Description
⑳ AC.POWER ⑱ 	Terminal for inputting power for driving the baking heater, auxiliary pump and air cooling unit. The voltage input to this terminal is output to the specified terminal block through operation of the STP pump.
② HEATER ① 	Terminal for connecting the baking heater. In either case of the following two types of operation under the NORMAL OPERATION state, voltage input to the <u>AC power terminal (⑱-⑳)</u> is output to this terminal. 1) Turn <u>ON</u> the HEATING switch on the front panel through <u>MANUAL Operation</u> . 2) Short the circuit between <u>I/O TB3 HEATING terminal ②-④</u> through <u>REMOTE Operation</u> (See <u>Section 7.3.2, "Interlocking the STP Pump Operation with Baking"</u>).
④ R.PUMP ③ 	Terminal for starting the auxiliary pump. The voltage input to the <u>AC. POWER terminal (⑱-⑳)</u> is output to this terminal through the STP pump rotation. DO NOT connect the auxiliary pump directly. Use separate power and a relay. Use another power and a relay. See Figure 8.2. <div style="display: flex; align-items: flex-start;"> <div style="border: 2px solid black; padding: 5px; margin-right: 10px;"> NOTICE </div> <p>If the I/O TB3 (①-③) is opened, it is diagnosed as abnormal auxiliary pump, the "FAILURE" lamp lights and the power is cut OFF.</p> </div>

*1: JIS

Table 8.1 I/O TB2 Terminal Block (2/2)

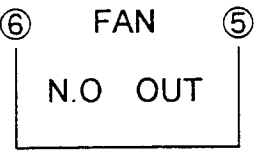
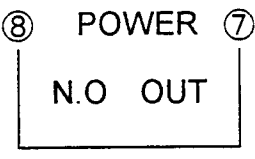
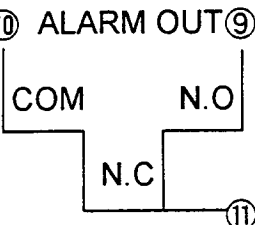
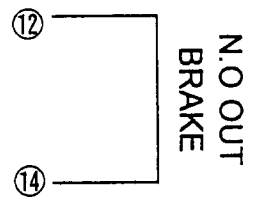
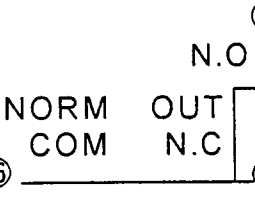
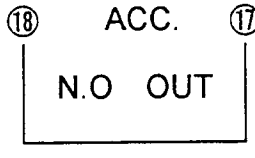
Terminal	Description
	<p>Terminal for connecting the air cooling unit. The voltage input to <u>AC. POWER</u> terminal (19-20) is output to this terminal when the STP pump is in acceleration or rated operation. The voltage is cut OFF when the STP pump is under the BRAKE state (See <u>Section 7.2.2, "Air Cooling Method"</u>).</p>
	<p>Terminal for outputting the POWER ON state signal. This terminal is closed when the magnetic bearing functions and the rotor levitates.</p>
	<p>Terminal for outputting the ALARM signal. When an abnormality/error is detected under the POWER ON state, the terminal between 10-9 is closed, and the terminal between 10-11 is opened.</p>
	<p>Terminal for outputting the BRAKE state signal. This terminal is closed when the STP pump is in brake.</p>
	<p>Terminal for outputting the NORMAL OPERATION state signal. When the STP pump is in rated operation, the terminal between 16-13 is closed, and the terminal between 16-15 is opened.</p>
	<p>Terminal for outputting the ACCELERATION state signal. This terminal is closed when the STP pump is in acceleration.</p>

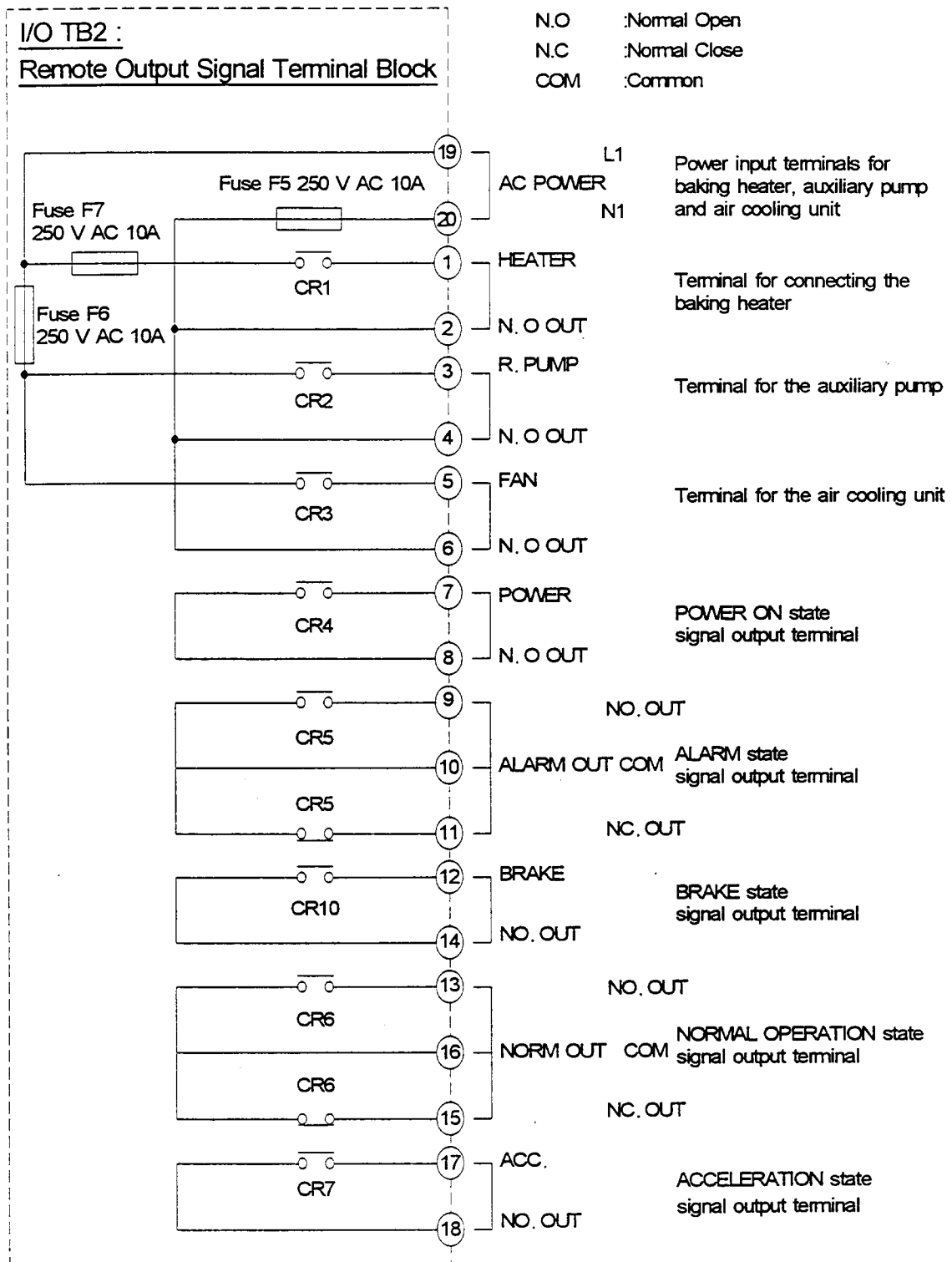

Figure 8.1 I/O TB2 Remote Output Signal Terminal Block

Table 8.2 shows rated contacts for relays CR1 to 4, CR7, and CR10 (See Figure 8.1) and CR8 (See Figure 8.4).

Table 8.2 Rated Contacts for Relays CR1 to 4, CR7, CR8 and CR10

	Resistance Load (cos ϕ =1)	Induction Load (cos ϕ =0.4) (L/R=7 ms)
Rated Load	250 V AC 10 A 30 V DC 10 A	250 V AC 5A 30 V DC 5A
Rated Current	10 A	
Maximum Contact Point Voltage	380 V AC 125 V DC	
Maximum Contact Point Current	10 A	
Maximum Open/Close Capacity	AC: 2500 VA DC: 300 W	AC: 1250 VA DC: 220 W
Minimum Applicable Load	5 V DC 10 mA	

Table 8.3 shows rated contacts for relays CR5 and 6 (see Figure 8.1).

Table 8.3 Rated Contacts for Relays CR5 and 6

	Resistance Load (cos ϕ =1)	Induction Load (cos ϕ =0.4) (L/R=7 ms)
Rated Load	250 V AC 10 A 30 V DC 10 A	250 V AC 7.5 A 30 V DC 5A
Rated Current	10 A	
Maximum Contact Point Voltage	380 V AC 125 V DC	
Maximum Contact Point Current	10 A	
Maximum Open/Close Capacity	AC: 2500 VA DC: 300 W	AC: 1875 VA DC: 150 W
Minimum Applicable Load	5 V DC 100 mA	

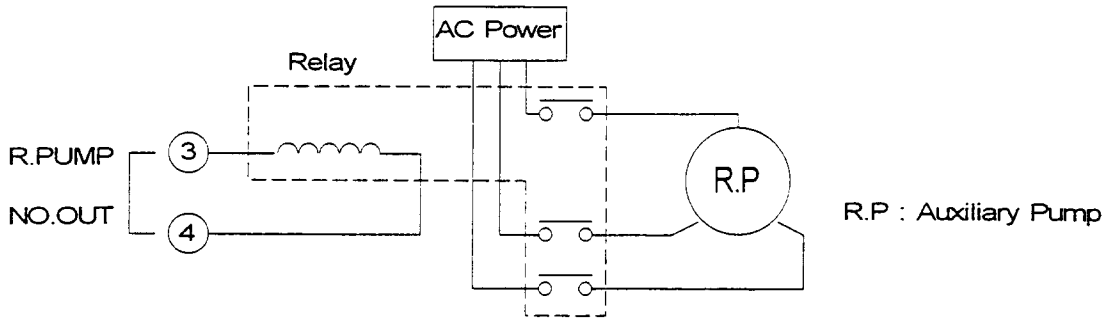

Figure 8.2 Example of Connecting I/O TB2 R. Pump Terminal

CAUTION

- ◇ When connecting optional power (over 25 V AC or over 60 V DC) to terminals ① to ⑥, ⑱ and ⑳, secure the remote cable using the attached cable fitting tool (see Figure 8.3).
DO NOT apply excessive force to the remote cable.
- ◇ DO NOT disconnect the ground cable for the metallic terminal block cover.

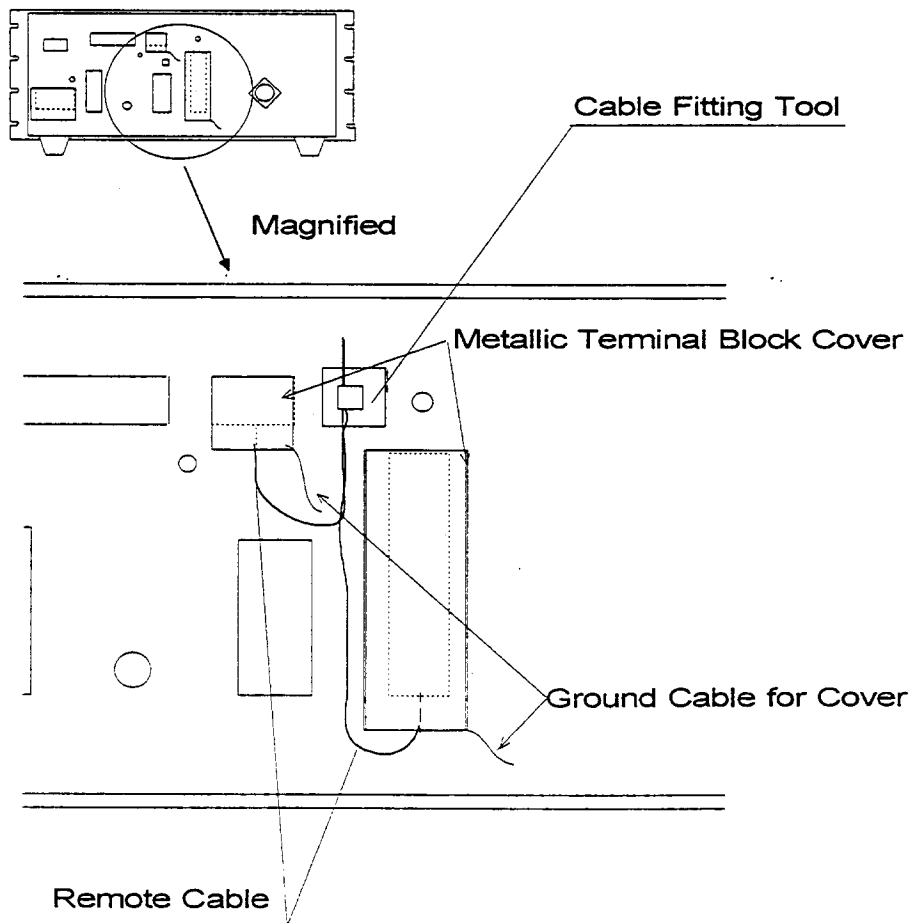

Figure 8.3 Example of Securing the Remote Cable

8.2 DC I/O TB3 Terminal Block

This is a terminal block for a remote input/output signal. Use it in accordance with Table 8.4 and Figure 8.4. Terminals excluding the HEATING terminal function in either case of the REMOTE/MANUAL operation.

The screw for the terminal is M3¹⁾.

Four abbreviations are used in the following tables:

- N.O :Normal Open
- N.C :Normal Close
- IN :Input Terminal
- OUT :Output Terminal.

Table 8.4 DC I/O TB3 Terminal Block

Terminal	Description
	<p>Terminal for connecting the thermal switch to protect the auxiliary pump.</p> <p>When the normal close type thermal switch for protecting the auxiliary pump is connected between this terminal, short the circuit between <u>I/O TB2 R.PUMP terminal ③-④</u> and stop the auxiliary pump.</p> <p>The "FAILURE" lamp lights.</p> <p>When this function is not used, short the circuit between ③-④ (shorted at delivery).</p>
	<p>Terminal for baking heater remote control.</p> <p>When the circuit between this terminal is shorted through the "<u>REMOTE</u>" operation, the voltage for the baking heater is output between <u>I/O TB2 HEATER terminal ①-②</u> during rated operation.</p>
	<p>Terminal for inputting the rotation INHIBIT signal.</p> <p>When the terminal is set to open, the STP pump does not rotate despite the STP pump operation.</p> <p>And only the auxiliary pump start voltage is output to <u>I/O TB2 R.PUMP terminal ③-④</u>.</p> <p>When this function is not used, short the circuit between ⑤-⑦ (shorted at delivery).</p>
	<p>Terminal for the emergency vent. valve operation signal.</p> <p>This terminal is closed while the emergency vent. valve is opened.</p>
	Ground
	Not-used

¹⁾ JIS

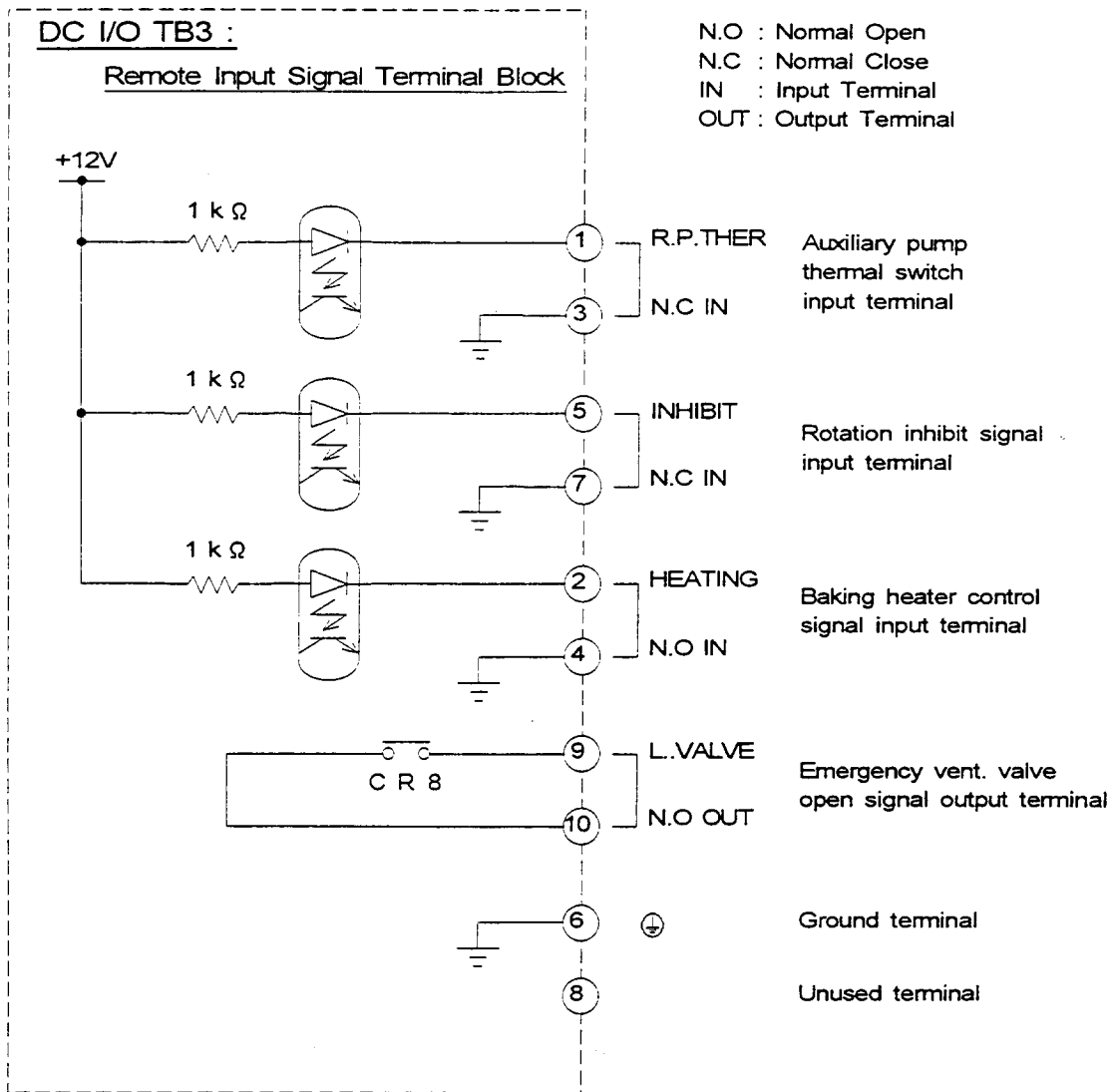

NOTICE

- ◇ Short the circuit between ①—③, when the R.P.THER terminal is not used.
- ◇ Short the circuit between ⑤—⑦, when the INHIBIT terminal is not used.
- ◇ See Table 8.2 for the contact ratings of relay CR8.

Figure 8.4 DC I/O TB3 Remote Input Signal Terminal Block

8.3 START STOP TB5 Terminal Block

This is a terminal block for a contact type remote input signal. Use it in accordance with Table 8.5 and Figure 8.5 (See Section 5.6.2. "Starting/Stopping the STP Pump").

The terminal block operates only during the REMOTE operation.

The screw for the terminal is M4¹.

Three abbreviations are used in the following tables:

N.O :Normal Open N.C :Normal Close
IN :Input Terminal

Table 8.5 START STOP TB5 Terminal Block

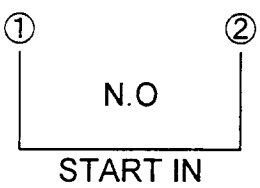
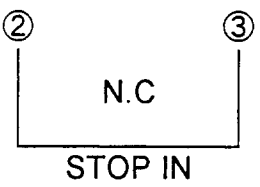
Terminal	Description
	<p>Terminal for the START signal input terminal. The following two methods are available:</p> <ol style="list-style-type: none"> 1) Short the circuit between terminals (②—③) for <u>0.3 seconds or more</u>. When this signal is input simultaneously with switching <u>ON</u> the breaker on the rear panel, short the circuit for <u>5 seconds or more</u>. 2) Short the circuit between terminals (①—③). In this case, terminal ② is not used.
	<p>Terminal for the STOP signal input terminal. The STOP signal has priority for the START signal. During the START operation input from terminal (①—②) of the START/STOP TB6 terminal block, the STP pump does not stop.</p> <ol style="list-style-type: none"> 1) In case of above 1): Rotation will stop when the circuit between this terminal is opened. 2) In case of above 2): Rotation will stop when the circuit between terminal (①—③) is opened.

¹: JIS

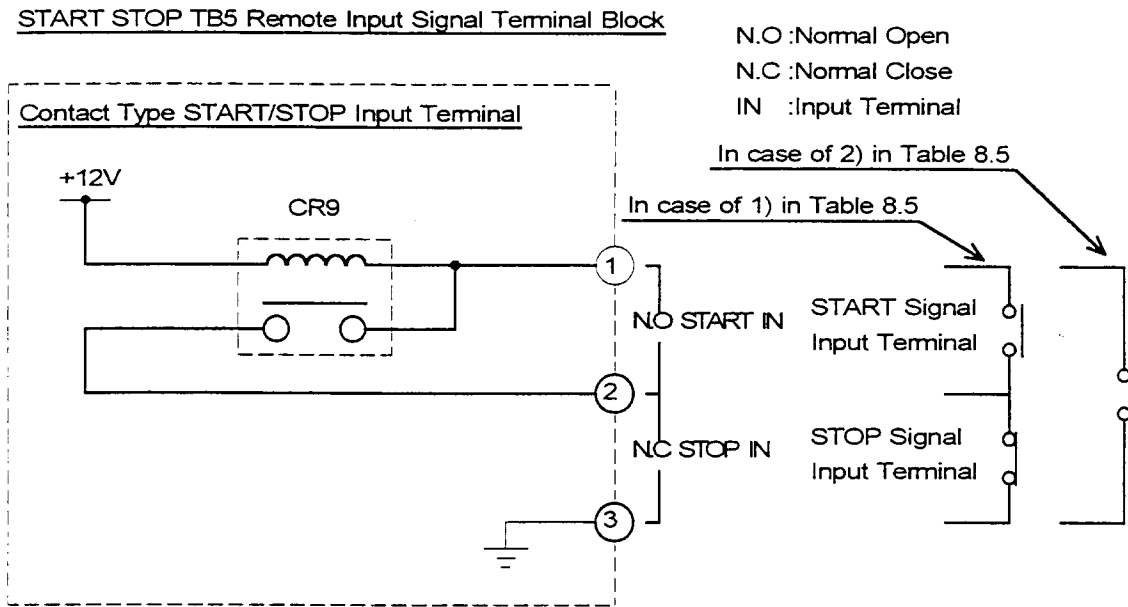

Figure 8.5 START STOP TB5 Remote Input Signal Terminal Block

8.4 START/STOP TB6 Terminal Block

This is a terminal block for a voltage type remote input signal.

Use it in accordance with Table 8.6 and Figure 8.6 (See Section 5.6.2, “Starting/Stopping the STP Pump”).

The terminal block operates only during REMOTE operation.

The screw for the terminal is M4^{*1}.

Table 8.6 START/STOP TB6 Terminal Block

Terminal	Description
 <p data-bbox="295 813 534 846">START/STOP IN</p>	<p data-bbox="603 658 1353 730">Terminal for the voltage type START/STOP signal terminal.</p> <p data-bbox="603 736 1385 853">When the voltage of <u>25 to 250 V AC</u> or <u>24 to 48 V DC</u> is applied between these terminals, the STP pump starts.</p> <p data-bbox="603 860 1362 931">When the circuit between these terminal is opened, the STP pump stops.</p> <p data-bbox="603 938 1378 1055">In case of DC input, the STP pump can start to rotate by connecting the plus (+) side either to <u>①</u> or <u>②</u>.</p>

CAUTION

- ◇ When connecting optional power (over 25 V AC) to terminals ① or ②, secure the remote cable using the attached cable fitting tool (See Figure 8.3).
DO NOT apply excessive force to the remote cable.
- ◇ DO NOT disconnect the ground cable for the terminal block cover.

*1: JIS

START/STOP TB6 Remote Input Signal Terminal Block

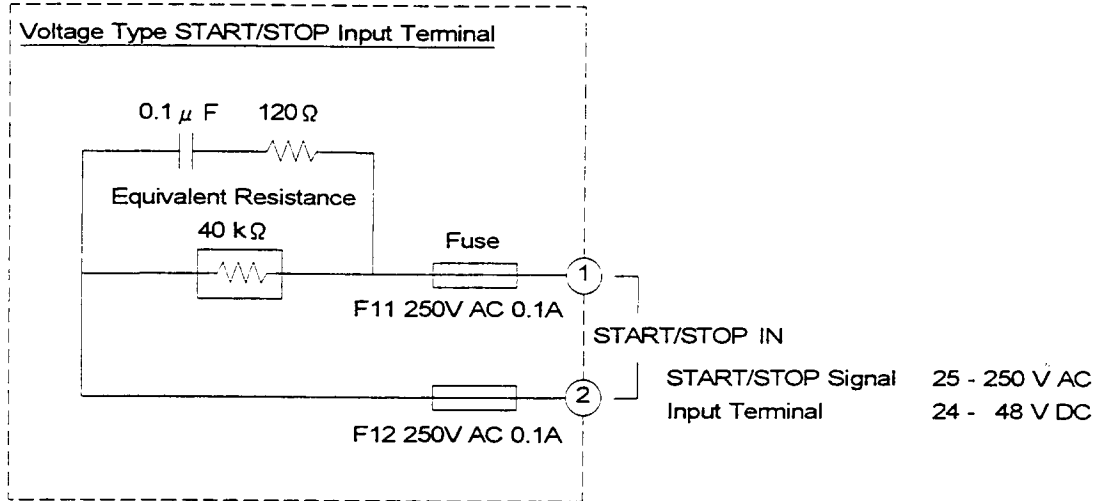

Figure 8.6 START/STOP TB6 Remote Input Signal Terminal Block

Section 9 Internal Battery

Four batteries (PORTALAC Series Small-Sized Sealed Lead-Acid Batteries, PE12V 2WS : 12V, 2Ah, manufactured by Japan Storage Battery Co., Ltd.) (hereinafter referred to as the internal battery) are inserted into the STP pump for backup during a power failure. These are rechargeable. During a power failure, power is supplied from the batteries, and levitation by a magnetic bearing continues for 6 minutes while the pump is decelerating and the rotor is landing.

Fully-charged batteries are capable of consecutively backing up the operation of the STP pump twice.

9.1 Life of the Internal Battery

The life of the internal battery is affected by ambient temperatures.

Pay attention to ambient temperatures (the operating ambient temperatures range from 0 to 40 °C).

Figure 9.1 shows the relationship between the ambient temperatures and the battery life.



- ◇ Replace the battery approx. once a year to make sure it is always ready to back up the operation of the STP pump.
For instructions on how to replace the battery, see Section 9.5, "How to Replace the Internal Battery."

9.2 Allowable Shelf Life of the Internal Battery

When the internal battery is left uncharged, its capacity will be reduced by self-discharge. The allowable shelf life of the internal battery is affected by ambient temperatures. Pay attention to its storage temperatures (the storage temperatures range from - 20 to + 40 °C).

Figure 9.2 shows the relationship between storage temperatures and the allowable shelf life of the internal battery.



- ◇ When the STP pump is left unused over the specified period, charge the internal battery for 90 minutes or more, or replace it with a new one before starting the STP pump. For instructions on how to recharge the internal battery, see Section 9.3, "How to Charge the Internal Battery." For instructions on how to replace the internal battery, See Section 9.5, "How to Replace the Internal Battery."

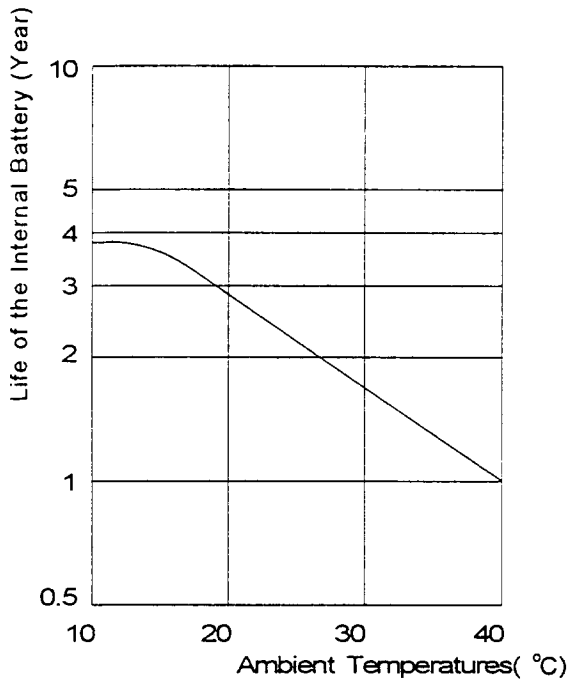

Figure 9.1 Life of the Internal Battery

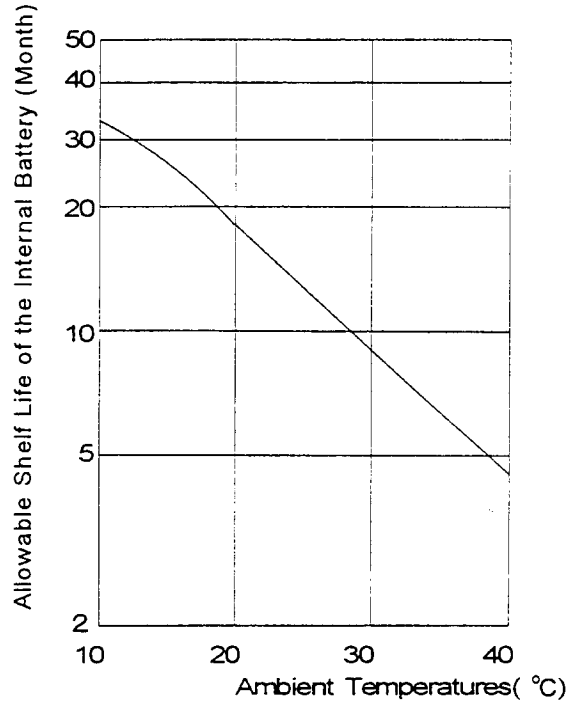

Figure 9.2 Allowable Shelf Life of the Internal Battery

9.3 How to Charge the Internal Battery

The battery is charged while the power is "ON," regardless of the operation state of the STP pump.

After a power failure, charge the battery for approx. 12 times the BATTERY BACKUP time. For example, when the BATTERY BACKUP time is 6 minutes, it takes approx. 75 minutes to charge the battery.

If a power failure occurs 2 times within 90 minutes, charge the battery for more than 90 minutes before starting to operate the STP pump.

9.4 Battery Capacity Low Warning (BATTERY NG) Lamp

If the capacity of the internal battery is reduced to the minimum level, the "BATTERY NG" lamp on the rear side of the STP control unit front panel (See Figure 9.3, "How to Replace the Internal Battery"), the "FAILURE" lamp, and the "EMERGENCY OPERATION" lamp on the STP control unit front panel light, and the STP pump does not start. Replace the battery with a new one and reset the "Battery Capacity Low Warning" (BATTERY NG) lamp. For instructions on how to replace the battery and restart the STP pump, see Section 9.5 "How to Replace the Internal Battery."



- ◇ When the " BATTERY NG" lamp lights, always replace the internal battery with a new one.



- ◇ When the power is turned on again, the "FAILURE" lamp goes out.

9.5 How to Replace the Internal Battery



- ◇ Turn OFF the primary power (Switch the breaker "OFF"), before replacing the battery.
Failure to do so may result in product damage or a problem due to electric shock or short-circuiting of the internal circuit.
- ◇ DO NOT touch any portions other than those designated.
Careless touch may cause electric shock and/or a short-circuiting of the internal circuit, resulting in product damage or a problem.
- ◇ DO NOT use a new battery and a worn-out battery simultaneously.
- ◇ DO NOT use different types of batteries simultaneously.

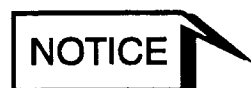

- ◇ When replacing the battery, record the next replacement date of the battery on the "Battery Instruction Label" (See Figure 9.3) on the front panel.
- ◇ The first replacement date of the battery has been specified on the "Battery Instruction Label" (See Figure 9.3) on the front panel at delivery.

9.5.1 How to Replace the Battery Case(See Figure 9.3.)

- 1) Stop the STP pump, and turn OFF the primary power (switch the breaker "OFF").
- 2) Unscrew the 4 screws attached to front panel ① and bring the front panel down towards you.
- 3) Disconnect internal battery connector ② (CON12).
- 4) Unscrew battery case screws ③ and pull out battery case ④ from the STP control unit.
- 5) Replace battery case ④ containing a new battery.
- 6) Tighten battery case screw ③ and secure the battery case ④.
- 7) Connect internal battery connector ② (CON12).
- 8) Turn ON the primary power (switch the breaker "ON") as well as the POWER switch. Then, check whether or not "BATTERY NG" lamp ⑦ on the rear side of the front panel lights.
- 9) If "BATTERY NG" lamp ⑦ located on the rear of the front panel lights, press RESET switch ⑧ on the side of "BATTERY NG" lamp ⑦ to reset it (although an impact noise may generate momentarily during reset, it is not indicative of a problem).
- 10) Turn OFF the POWER switch and the primary power (Switch the breaker "OFF").
- 11) Close front panel ① and tighten the 4 screws that secure the front panel.
- 12) Record the next replacement date (after one year) of the battery on "Battery Instruction Label" ⑨ attached to the front panel (See Figure 9.3).

9.5.2 How to Replace the Battery in the Battery Case(See Figure 9.3.)

- 1) Remove front plate ⑤ from battery case ④ by unscrewing 4 M2 screws.
- 2) Disconnect battery internal connector ⑥.
- 3) Remove inside plate⑩ from battery case by unscrewing 4 M2 screws and pull out the battery from the case (it can be pulled out toward you).
- 4) Replace the four worn-out batteries with new ones, the side, from which the cord projects, up.
- 5) Attach inside plate⑩.
- 6) Connect battery internal connector ⑥ and attach front plate ⑤ to the battery case (Be careful not to catch the cable).



- ◇ New batteries and battery cases are supplied by Seiko Seiki.

①	STP Control Unit Front Panel
②	Internal Battery Connector
③	Battery Case Screw
④	Battery Case
⑤	Battery Case Front Plate
⑥	Battery Internal Connector
⑦	Battery Capacity Low Warning (BATTERY NG) Lamp
⑧	RESET Switch
⑨	Battery Instruction Label
⑩	Battery Case Inside Plate
⑪	Flat Head Screw (M2)

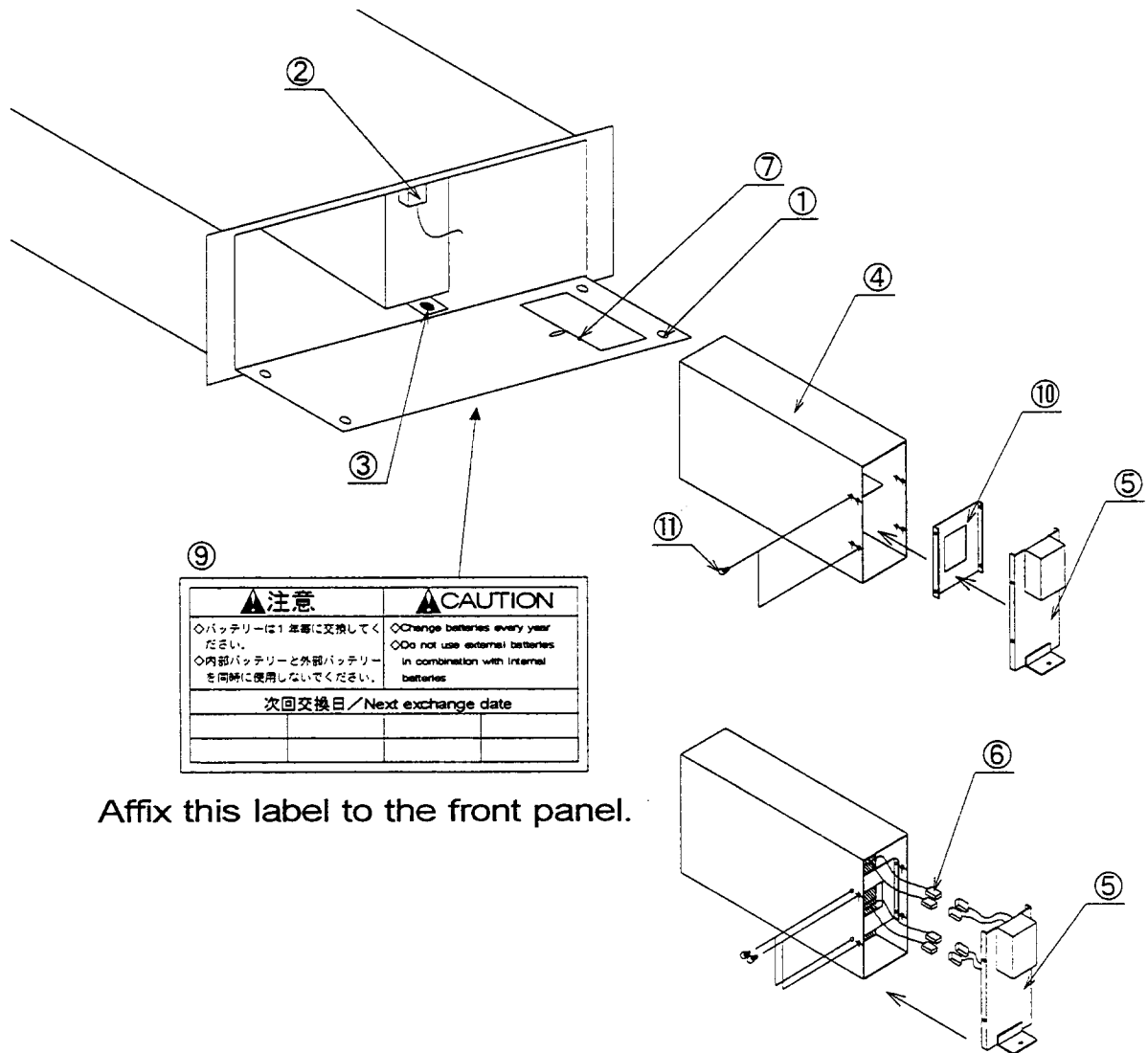

Figure 9.3 How to Replace the Internal Battery

9.6 How to Dispose of the Internal Battery

Dispose of or collect worn-out batteries in accordance with the guidelines given by each national and/or local government. If you procure batteries, dispose of them in accordance with the guidelines given by the battery manufacturer.



- ◇ Pay attention to short-circuiting or leakage of the batteries when disposing of them.
- ◇ To prevent the batteries from short-circuiting, remove the lead wires and connectors from the batteries.
Cut the lead wires one by one so as not to cause a short-circuiting.
- ◇ Coat the conductive part of the batteries with tape.



- ◇ It is recommended to dispose of worn-out batteries after discharging them thoroughly.
- ◇ Batteries manufactured by Japan Storage Battery Co., Ltd. will be collected by Japan Storage Battery Co., Ltd. For detailed information, contact Japan Storage Battery Co., Ltd. or Seiko Seiki.

Section 10 External Battery



- ◇ DO NOT use (an) external batteries when internal batteries are inserted. Failure to do so may result in product damage or a problem.
It could cause a problem, such as product damage.
- ◇ DO NOT connect batteries in parallel.
- ◇ Replace batteries with new ones before the end of their life.
- ◇ When the STP pump is left unused over the specified period, charge battery for 90 minutes, or replace it with a new one before starting the STP pump.



- ◇ The life, allowable shelf life, and operation frequency of the battery differ depending upon the type of the battery and ambient temperatures. See technical data and information prepared by the battery manufacturer.

10.1 Specifications for the External Battery

When you use external batteries, select one in accordance with the specifications given in Table 10.1.



- ◇ If you use external batteries which do not conform to the specifications, battery backup will not function during a power failure which could result in damage to the STP pump.

Table 10.1 Specifications for the External Battery

Item	Specifications
Capacity	1.8 Ah or more
Voltage	48 V
Current	2.3 A
Operation time	Approx. 6 minutes
Operation frequency	Continues 2 times or more
Charging voltage	55 V

It is recommended to use PORTALAC Series Small-Size Sealed Lead-Acid Battery manufactured by Japan Storage Battery Co., Ltd. as an external battery.