

1.855.882.2886

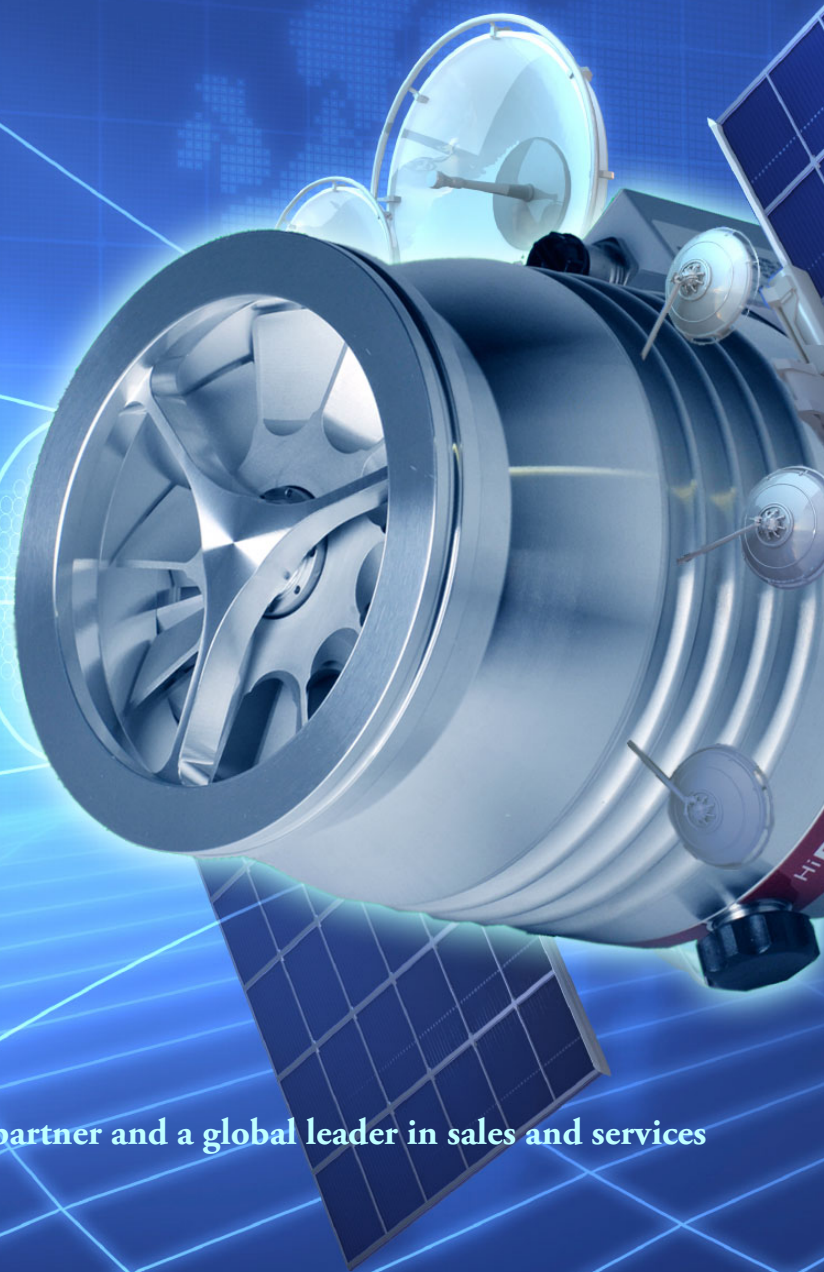

# AJVS

[www.ajvs.com](http://www.ajvs.com)



A&J Vacuum Services is your highly qualified partner and a global leader in sales and services of your High Vacuum equipment.

A&J Vacuum Services, Inc.  
790 Bloomfield Ave., Suite B3  
Clifton, NJ 07012, USA  
Tel: 973-249-0854  
Fax: 973-249-0855  
Website: [www.ajvs.com](http://www.ajvs.com)

Customer Service: [info@ajvs.com](mailto:info@ajvs.com)  
Sales Inquiries: [sales@ajvs.com](mailto:sales@ajvs.com)  
Service Inquiries: [service@ajvs.com](mailto:service@ajvs.com)  
Technical Assistance: [tech@ajvs.com](mailto:tech@ajvs.com)  
Order Status: [tracking@ajvs.com](mailto:tracking@ajvs.com)

## HiMag™ Turbomolecular Pump With Magnetic Bearings And Power Supply



### HiMag™ 2400

PT 0134 BE/F (0603)

# Contents

	Page		Page
<b>1. Safety Instructions .....</b>	<b>3</b>	4.11. Gas Type Dependent Operation .....	18
1.1. For Your Orientation.....	3	4.12. Switching OFF And Venting .....	19
1.2. Pictogram Definition.....	3	4.13. Emergency Stop .....	19
<b>2 Understanding The Turbopump .....</b>	<b>4</b>	4.14. Safety Bearings.....	20
<b>HiMag™ 2400</b>		4.15. Monitoring Of The Balancing Condition .....	20
2.1. Main Features.....	4	4.16. Emergency Power Operation.....	20
Proper Use .....	5	4.17. Shut Down For Longer Periods.....	20
Improper Use .....	5	4.18. Remote Control Operation .....	21
2.2. Differences Between The Pump Types.....	5	Operating Modes With Remote Control .....	21
2.3. Scope Of Delivery .....	5	4.19. Vent Modes .....	22
<b>3. Installation .....</b>	<b>6</b>	4.20. Configuration Of The Analog Output.....	22
3.1. Preparations for Installation .....	6	4.21. Switching Outputs.....	22
3.2. Connecting The High Vacuum Side .....	6	<b>5. Error Messages And Warnings .....</b>	<b>23</b>
3.3. Connecting The Fore-Vacuum Side .....	10	5.1. Error Messages / Status Messages .....	23
3.4. Connecting The Cooling Unit .....	10	5.2. Warnings .....	24
3.5. Electronic Drive Unit And .....	11	<b>6. Parameters .....</b>	<b>25</b>
Magnetic Bearing Controller TM 3000		6.1. General .....	25
General Unit Description .....	11	6.2. Setting Commands.....	25
Connecting The TM 3000 To The Power Supply .....	11	6.3. Status Requests .....	26
3.6. Connecting The Venting Valve.....	12	6.4. Set Points .....	27
And Sealing Gas Valve		<b>7. Monitoring The .....</b>	<b>28</b>
3.7. Connecting The Remote Control.....	12	<b>Operating Conditions</b>	
Plug Arrangement REMOTE .....	13	7.1. Operating Mode Display Via LED .....	28
3.8. Connecting The Serial Interface .....	14	7.2. Temperature Monitoring Of The Turbopump .....	28
Using A DCU Or HPU		<b>8. What To Do In Case Of .....</b>	<b>29</b>
Electrical Connection .....	14	<b>Breakdowns?</b>	
Bus Operating Via RS 485 Interface.....	14	<b>9. Service .....</b>	<b>30</b>
3.9. Connections Diagram.....	15	<b>10. Maintenance/Replacement .....</b>	<b>31</b>
<b>4. Operations.....</b>	<b>16</b>	10.1. Replacing The Power Supply.....	31
4.1. General Operating Information.....	16	<b>11. Technical Data .....</b>	<b>32</b>
4.2. Operating Modes .....	16	11.1. Dimensions Diagram .....	33
4.3. Before Switching ON.....	16	<b>12. Accessories .....</b>	<b>35</b>
4.4. Switching ON .....	16	<b>Declaration of Contamination .....</b>	<b>36</b>
4.5. Normal Operation Of The Turbo Pump .....	17	<b>Manufacturer's Declaration .. (last page)</b>	
4.6. Standby Rotation Speed ON/OFF.....	17		
4.7. Turbo Drive ON/OFF.....	17		
4.8. Rotation Speed Switch Point .....	17		
4.9. Rotation Speed Set Mode.....	17		
4.10. Backing Pump Operation.....	17		

**Please note:** Current operating instructions are available via [www.pfeiffer-vacuum.net](http://www.pfeiffer-vacuum.net).

# 1. Safety Instructions

- ☞ Please read and follow all items in these instructions.
- ☞ Please familiarize yourself with:
  - Hazards associated with the turbopump
  - Hazards associated with your system
  - Hazards associated with the pumped media
- ☞ Ensure that no body parts are exposed to the vacuum.
- ☞ Follow all safety and accident prevention instructions.
- ☞ The turbopump, magnetic bearing controller and power supply have no lock-out/tag-out device and no emergency stop, since they are designated for use on process tools. Therefore they must be properly included in the higher-level equipment control.
- ☞ Regularly check for proper observance of all safety measures.
- ☞ Do not operate the turbo pump with an open high vacuum flange.
- ☞ Do not make any alterations or modifications to the turbopump.
- ☞ Follow all shipping instructions when returning the turbopump.
- ☞ In order to put the turbopump, magnetic bearing controller and power supply in a safe condition for installation and maintenance, the power supply must be completely disconnected from the mains.
- ☞ The installation instructions in Section 3. must be followed when installing the turbopump.
- ☞ Do not remove the plug between the electronic and the accessories during operation.
- ☞ Before opening the turbopump, make sure that the Magnetic Bearing Controller TM 3000 is disconnected from the mains.
- ☞ When working on the turbo pump, open the HV flange only after the rotor has come to a complete stop.
- ☞ When using sealing gas, limit the pressure in the hose connection to 3 bar using the relief pressure valve.
- ☞ The housing can reach temperatures of up to 100 °C.  
Caution – danger of burns!
- ☞ During operations temperatures of up to 65 °C can arise in the lower part of the turbopump.  
Caution – danger of burns!
- ☞ Keep wiring and cables away from hot surfaces (>70 °C).
- ☞ The Turbopump HiMag™ 2400 should only be operated with the accordingly connecting cable.
- ☞ The turbopump and Magnetic Bearing Controller TM 3000 should never be separated.
- ☞ The unit has an IP 54 protection class. Appropriate measures should be taken in environments that require a different protection class.
- ☞ The mains connection must always be grounded (PE) (Protection class 1).
- ☞ The turbopump can reach temperatures of up to 150 °C during operation. If the pump is vented with flammable gases with pressures over approximately 100 mbar in this state, there is a risk of combustion.
- ☞ -Keep the operating manual readily available at all times.
- ☞ - Always use suitable aids for transporting the pump.

## 1.1. For Your Orientation

### Instructions in the Text

➔ Indicates an action to be taken.

### Symbols used

The following standard symbols are used in all figures:

- Ⓜ High vacuum flange
- Ⓥ Fore-vacuum flange
- ⓔ Venting connection
- Ⓧ Cooling water connection
- ⚡ Electrical connection
- ⓐ Sealing gas connection

### Abbreviations used

- DCU = Display and operating unit
- HPU = Display and operating unit
- TM = Electronic drive unit and magnetic bearing controller
- OPS = Power supply
- TMP = Turbomolecular pump

### Item numbers

All units and accessories have the same item numbers in all figures.

## 1.2. Pictogram Definition



Warning, risk of personal injury.



Caution, risk of damage to the pump or system.



Warning, risk of injury from rotating components.



Please note, important information about the product, handling of the product or part of the documentation requiring special attention.

## 2. Understanding The Turbopump HiMag™ 2400

### 2.1. Main Features

The Turbopump HiMag™ 2400 constitutes a complete unit with the Electronic Drive Unit And Magnetic Bearing Controller TM 3000 and the integrated Power Supply.

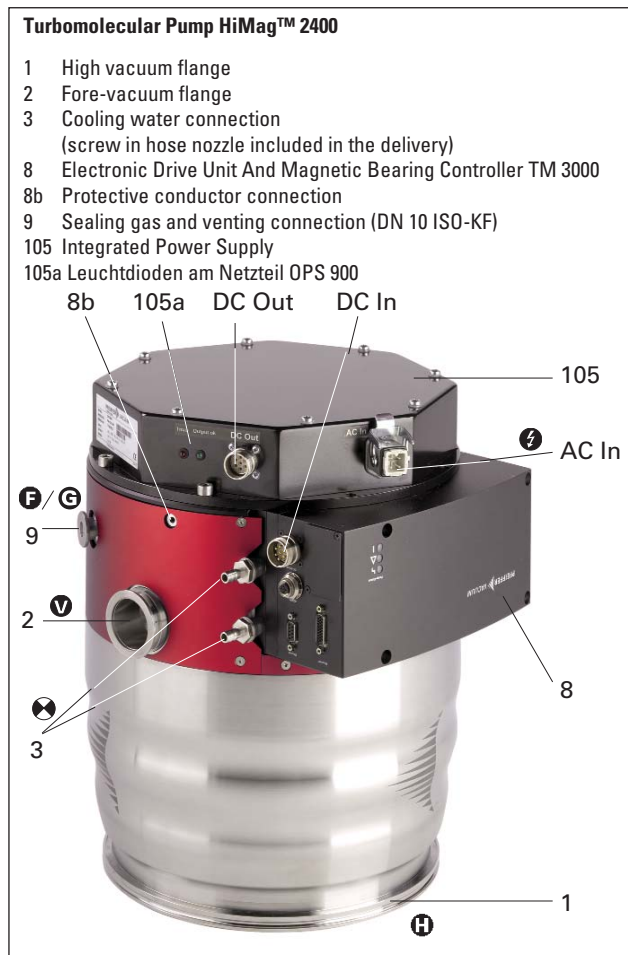

#### Cooling

Water cooling

Internal protective measures for excess temperatures:

Electronic Drive Unit And Magnetic Bearing Controller TM 3000 reduce rotor speed.

#### Bearings

Two non-wearing, electromagnetic radial and axial bearings.  
Plus: dry-running safety bearing

#### Transportation



During transportation and installation work do not expose the Electronic Drive Unit And Magnetic Bearing Controller TM 3000 and the Power Supply OPS 900 to mechanical stress. In order to ensure that no contaminants can enter into the turbopump, the protective covers and the blank flanges must only be removed immediately before installing the pump

- ➔ The turbomolecular pump must be lifted out of the packaging and transported by making use of the two eye bolts A fitted at the bottom side of the turbomolecular pump into which one crane hook each is inserted.

When transporting the turbomolecular pump, under all circumstances observe the following:

- Always use both eye bolts.
- The angle of the crane's chains must not exceed 60° with respect to the longitudinal axis of the pump.
- With the crane hooks, additional weights (for example a vacuum chamber) must never be lifted simultaneously.
- If the Power Supply OPS 900 has been detached from the pump, the two included eye bolts must not be used to lift or transport the pump.
- The pump must, with its own weight only, be carefully lowered onto the Power Supply OPS 900.



If after transporting the pump the two eye bolts A are removed from the pump, the cylinder head screws with hexagon sockets supplied must be screwed in instead.

To ensure heat dissipation during operation, the power supply needs to be attached firmly to the turbomolecular pump using **6** cylinder head screws with hexagon socket or **4** cylinder head screws with hexagon socket and **2** eye bolts.

### Ambient conditions

The turbomolecular pump needs to be installed in compliance with the following ambient conditions:

<b>Installation location:</b>	protected against the weather (rooms within buildings)
<b>Temperature:</b>	+5 °C to +40 °C
<b>Relative humidity of the air:</b>	max. 80 % at T ≤ 31 °C up to max. 50% at T ≤ 40 °C
<b>Air pressure:</b>	77 kPa - 106 kPa
<b>Installation altitude:</b>	2000 m max.
<b>Pollution degree:</b>	2
<b>Overvoltage category:</b>	II
<b>Connection voltage:</b>	208–240 VAC (±10%)

### Function of the LED on the power supply OPS 900

<b>Output OK:</b>	LED glows green; Power supply OK
<b>Tmax:</b>	LED glows red; By the protective functions temperature rise, overcurrent or overvoltage was switched off the power supply. The function overvoltage is put back by mains interruption.

### Function of the LED on the TM 3000

Refer to section 7.

### Proper Use

- The Turbopump HiMag™ 2400 may only be used to generate a vacuum.
- The turbopump is intended for pumping corrosive gases and vapors. During corrosive gas processes, gaseous compounds and particles that can damage the pump surfaces are generated. The motor and bearing chamber must be protected with sealing gas.
- Only media to which the turbopump is chemically resistant may be pumped. The user must qualify the pump for the process if other media are to be used.
- If process dust occurs, process-specific maintenance intervals should be arranged with the manufacturer and sealing gas should be used.
- Sealing gas should be used to guarantee cooling if the pump is operated at maximum gas load. Otherwise automatically a power reduction takes place (see Section 4.11.).
- The turbopump must be connected to a fore-vacuum pump as described in Section 3.3.
- The turbopump may only be operated using the appropriate Pfeiffer Vacuum cables.
- The pump should only be installed in compliance with the environmental conditions of protection class IP 54.

### Improper Use

The following are considered improper use:

- Pumping of explosive gases
- Using the pump in areas with a risk of explosion.
- Operating the pump in areas there is a danger of radioactivity.
- Pumping gases and vapors that harm the materials of the pump.
- Pumping corrosive gases without sealing gas.
- Pumping condensing vapors.
- Operation at unacceptably high gas loads.
- Operation at unacceptably high fore-vacuum pressure.
- Operation with incorrect gas mode.
- Operation with excessive heat radiation power (see Section 11. Technical Data).
- Installation in environments requiring a protection class higher than IP 54.
- Installation of the pumps in systems where the turbomolecular pumps are subjected to impact-like stress and vibrations or the effect of periodically occurring forces.
- Use of accessories not mentioned in these instructions or not approved by the manufacturer.

The turbomolecular pumps and flange connections must not be used to tread on when climbing onto the system.

Unauthorized use renders all liability and guarantee claims void.

## 2.2. Differences Between The Pump Types

Feature	HiMag™ 2400		
High vacuum flange	ISO-K	ISO-F	CF-F
High vacuum seal	Aluminium	Aluminium	Copper
Achievable final pressure	< 1 · 10 <sup>-9</sup> mbar		

## 2.3. Scope Of Delivery

Turbopump HiMag™ 2400 with:

- Electronic Drive Unit And Magnetic Bearing Controller TM 3000,
- Power Supply OPS 900,
- Connecting cable TM 3000 - power supply,
- Protective covering for high vacuum flange and fore-vacuum flange,
- two pieces of eye bolts for transportation the pump,
- two pieces of socket cap screws (for use see Section 2.1.).

# 3. Installation

## 3.1. Preparations For Installation



Do not carry out any unauthorised conversions or alterations to the turbopump.



In case the rotor blocks suddenly, torque levels up to **36,000 Nm** can occur which need to be absorbed by the system and the high vacuum flange.

- The high vacuum side of the pump may not be flanged on via a vibration compensator, since thereby no safe connection is to be ensured.
- If the turbopump is to be operated with the DCU 001 or HPU 001, then proceed in accordance with the corresponding operating instructions (please see Section 12. Accessories).
- The maximum permissible rotor temperature of the pump is 120 °C. If the vacuum chamber or parts in the vacuum chamber are heated, the values stated in the technical data relating to the level of heat which may be radiated into the pump must not be exceeded. If necessary, suitable shielding must be fitted in the vacuum chamber before the turbopump (constructional suggestions available on request).
- Only remove the blank flange from the high and fore-vacuum side immediately before connection.
- Where magnetic fields of > 10 mT are involved suitable shielding must be provided (available on request).
- Floor mounting of the turbomolecular pump is not permissible.



The person responsible for commissioning must ensure that the installation is carried out in accordance with the legal regulations and the pertinent industrial standards.  
All work on the pump must be performed only by qualified personnel who are familiar with all warnings and safety measures of this operating manual.

## 3.2. Connecting The High Vacuum Side



The utmost cleanliness must be observed when fitting all high vacuum parts. Unclean components prolong the pumping time. All installation units for the flange must be dry and free of grease and dust.



To reliably prevent the pump from twisting if the rotor suddenly blocks, it is absolutely prohibited to secure a pump with an ISO-K flange on a vacuum chamber with an ISO-F flange or vice versa. Both flanges **must** be of the same type. Installation with different flange types is carried out at the user's own risk. Pfeiffer Vacuum shall assume no liability whatsoever for any damage or injuries resulting from this kind of attachment.

### Use a Pfeiffer Vacuum splinter shield or protective mesh

The use of a Pfeiffer Vacuum centering ring with splinter shield or protective mesh in the high vacuum flange protects the turbopump against foreign bodies coming from the vacuum chamber but does reduce the volume flow rate as followed:

		Reduced volume flow rate [%]		
		N <sub>2</sub>	He	H <sub>2</sub>
Splinter shield	DN 250	23	10	7
Protective mesh	DN 250	7	3	2

## Installing the high vacuum flange

- In case the rotor blocks suddenly, torque levels up to **36,000 Nm** can occur which need to be absorbed by the system and the high vacuum flange.
- The turbopump should be flanged directly to the vacuum chamber or with a small space between them. This minimizes the force on the vacuum-chamber flange in case of seizing. Connecting parts must transfer this force on the vacuum chamber or absorb it themselves.
- For installing the turbomolecular pumps to the high vacuum flange, the components listed in the following **must** be used exclusively. Otherwise the turbomolecular pump may twist or tear off. The clamps, bolts, nuts and centering rings are special designs from Pfeiffer Vacuum.
- The minimum strength of 170 N/mm<sup>2</sup> of the flange material needs to be observed.

Installation is done as follows:

## ISO-K to an ISO-K flange

The components for installation are enclosed in the appropriate set of mounting material (see section 11 Accessories).

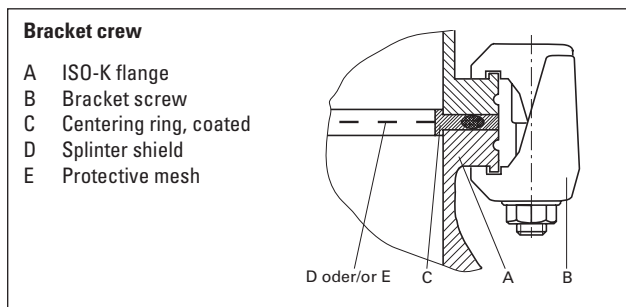

- ➔ See that the sealing surface is not damaged.
- ➔ Flange the turbopump according to the drawing and the component parts in your set of mounting material.
- ➔ Tighten the 28 clamps crosswise in three steps.  
Tightening torque: 5 Nm, 15 Nm, 25 ±2 Nm

## ISO-F to an ISO-F flange

For installing there exist three variants. The components for installation are enclosed in the appropriate set of mounting material (see section 11 Accessories).

### Variant 1 - Hexagon screw with blind hole

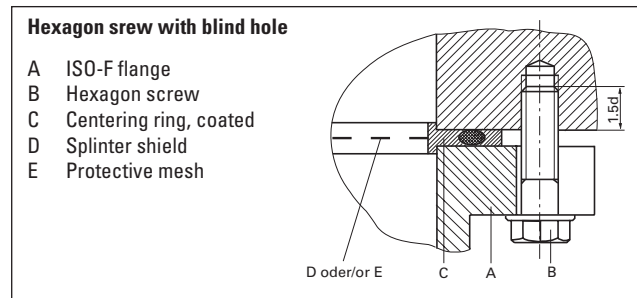

- ➔ See that the sealing surface is not damaged.
- ➔ Flange the turbopump according to the drawing and the component parts in your set of mounting material. Use 12 hexagon screws
- ➔ For a flange material having a strength of > 270 N/mm<sup>2</sup> and with a blind hole the hexagon screw 1,5 d must be screwed in. The hexagon screws must be tightened crosswise in three steps.  
Tightening torque: 10 Nm, 20 Nm, 38 ±3 Nm

### Variant 2 - Stud screw with blind hole

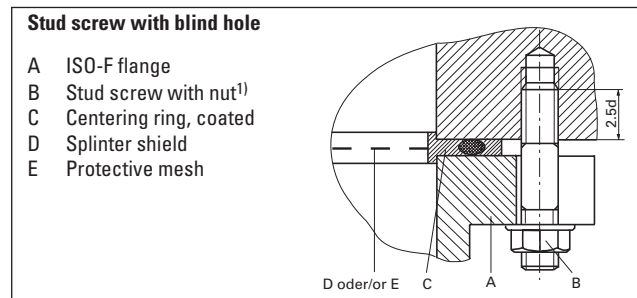

1) Nut with flange.

- ➔ See that the sealing surface is not damaged.
- ➔ Flange the turbopump according to the drawing and the component parts in your set of mounting material. Use 12 screws and 12 nuts.
- ➔ For a flange material having a strength of 170-270 N/mm<sup>2</sup> and a screw-in flange, the 12 stud screw 2,5 d must be screwed in. The nuts must be tightened crosswise in three steps.  
Tightening torque: 10 Nm, 20 Nm, 38 ±3 Nm

### Variant 3 - Stud screw and clearance hole

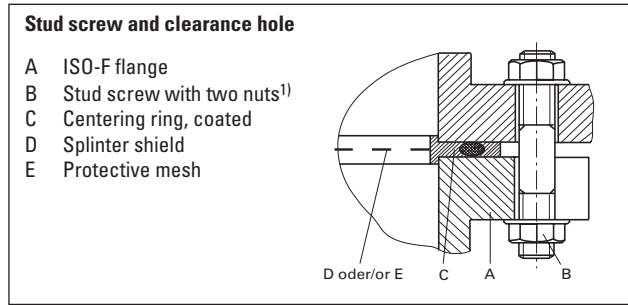

1) Nut with flange.

- ➔ See that the sealing surface is not damaged.
- ➔ Flange the turbopump according to the drawing and the component parts in your set of mounting material. Use 12 screws and 24 nuts.
- ➔ For a flange material having a strength of  $> 170 \text{ N/mm}^2$  and a stud screw with clearance hole, the nuts must be tightened crosswise in three steps.  
Tightening torque: 10 Nm, 20 Nm,  $38 \pm 3 \text{ Nm}$

### CF-F flange

Applications for installing an CF-F to an CF-F flange are "Stud screw with blind hole" and "Hexagon screw and clearance hole". The following items are needed: the particular set of mounting material and a copper seal. Using a splinter shield or protective mesh is optional.



Don't touch the copper seal with bare hands, this may affect the sealings efficiency. See that the sealing lip is not damaged.

### Stud screw with blind hole

- ➔ If used: Insert the splinter shield and protective mesh in the high vacuum flange with the clamping lugs downward.
- ➔ Bring the seal centric into the correct position.
- ➔ Connect the flanges via **32** pieces of stud screws (M8) with washers and nuts. The stud screws need to be tightened revolving with a tightening torque of  $22 \pm 2 \text{ Nm}$ . Control the torque afterwards, because of the sealing material's flowing a retightening of the screws may be required.

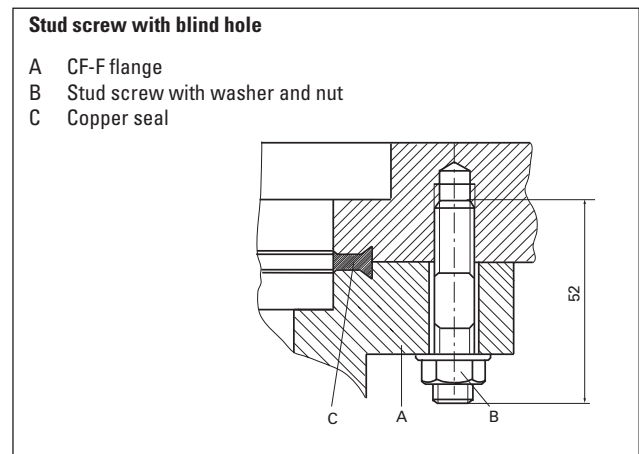

### Hexagon screw and clearance hole

- ➔ If used: Insert the splinter shield and protective mesh in the high vacuum flange with the clamping lugs downward.
- ➔ Bring the seal centric into the correct position.
- ➔ Connect the flanges via **32** pieces of hexagon screws (M8) with washers and nuts. The hexagon screws need to be tightened revolving with a tightening torque of  $22 \pm 2$  Nm. Control the torque afterwards, because of the sealing material's flowing a retightening of the screws may be required.

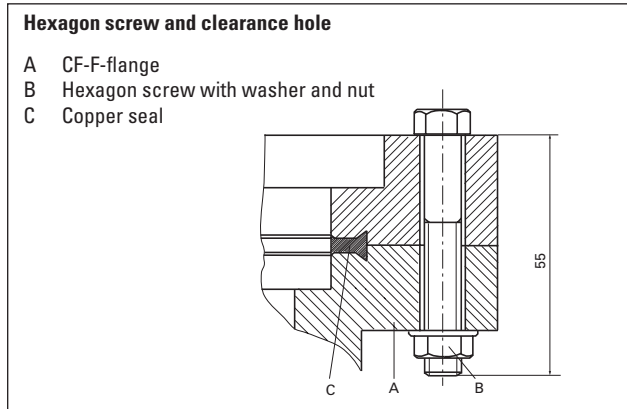

The components for installing to an CF-F flange are to be ordered under the following numbers:

Connection nominal-diameter	Designation	Order-number
DN 250 CF-F	Hexagon screw M8 with washer and nut (25 pieces <sup>1)</sup> )	PF 505 004 -T
	Stud screw M8 with washer and nut (34 pieces <sup>1)</sup> )	PF 507 004 -T
	Copper seal (5 pieces <sup>1)</sup> ) or copper seal silvered (5 pieces <sup>1)</sup> )	PF 501 425 -T PF 501 525 -T
	Splinter shield <sup>2)</sup>	PM 016 324
	Protective mesh <sup>2)</sup>	PM 016 345

1) supplied pieces

2) Insert the splinter shield and the protective mesh in the high vacuum flange with the clamping lugs downward.

### Flanging the pump directly

The pump can have any mounting position.

If you use a horizontal mounting position for the turbopump, we recommend installing the fore-vacuum flange towards the bottom to avoid polluting the turbopump.



Max. axial loading capacity of the high vacuum flange 2000 N (corresponding to 200 kg).  
 No one-sided loads on the high vacuum flange.

Vibration of the pump can lead to overloading of the magnetic bearing and require the safety bearing. Try to avoid vibrations as much as possible!

System-specific excitations, e.g. through a high vacuum valve, require the pump to be fastened in such a way that it cannot move and particularly cannot tip.



For anchored turbopumps, forces from the piping should not affect the pump. All piping should be supported or uncoupled in front of the pump.

### Earthquake safety

An earthquake can result in contact with the safety bearings; see chapter 4.14. All forces occurring thereby are safely absorbed by the previously described flange connections. The vacuum chamber, in turn, must be secured against shifting and tipping.

#### Example: How to secure against shifting and tipping

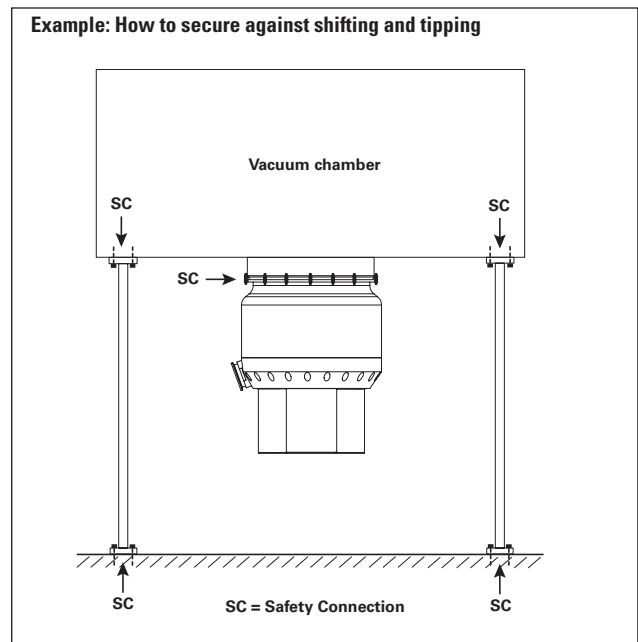

### 3.3. Connecting The Fore-Vacuum Side

Fore-vacuum pump: See Section 11. Technical Data for fore-vacuum pressure  
 Recommendation: Dry fore-pump or dry pumping station from the Pfeiffer Vacuum range.

#### Connecting the fore-vacuum pump

All connections on the fore-vacuum line: conventional small-flange components or hose connections.



Securely divert the gas exhaust from the backing pump! Do not restrict the open cross-section of the fore-vacuum flange with additional components!



The exhausted process gases and vapors can be dangerous to health and the environment. Observe all safety recommendations from the gas manufacturer. Check the seal of the fore-vacuum line before commissioning.

- ➔ For rigid pipe connections: Install bellows to attenuate vibrations in the connection line.
- ➔ A valve is required for the fore-vacuum line to protect the turbopump from reverse venting in the case of uncontrolled switching off of the backing pump.
- ➔ A relay box (see Section 11. Accessories) can be used for the fore-vacuum pump's electrical connection. The relay box control line should be connected to the "Remote" connector (Pin 11/Pin 26) of the Magnetic Bearing Controller TM 3000 in accordance with the connection diagram (see Section 3.9.).

For more detailed information about the fore-vacuum pump relay box and its installation, see Operating Instructions PT 0030 BN.

### 3.4. Connecting The Cooling Unit

The Turbopump HiMag™ 2400 must be operated with water cooling.  
 (For cooling water connections, see Section 11.1. Dimension Diagram)

#### Water cooling

Cooling water either  
 – from cooling water net or  
 – from TZK recycled water cooling unit (see Section 12. Accessories) with closed circulation.

#### Cooling from cooling water net

The cooling water must be filtered to avoid deposits in the pump!

#### Minimum requirements for the cooling water:

Mechanically pure, optically clear, no cloudiness, no sediment, chemically neutral, temperature > dew point.

Oxygen content:	max. 4 mg/kg
Chloride content:	max. 100 mg/kg
Carbonate hardness:	max. 10 °dH
Potassium permanganate consumption:	max. 10 mg/kg
Carbonic acid:	not detectable
Ammonia:	not detectable
pH value:	7 – 9
Flow pipe excess pressure:	max. 6 bar
Minimum flow rate at max. gas load:	100 l/h

#### Connection to cooling water net

- ➔ Unscrew locking screws from the cooling water connections and screw in the delivered hose nozzles with associated seal (tightening torque: 10 Nm).
- ➔ Install dirt trap (see Section 12. Accessories) in the flow line.
- ➔ Connect flow line to the upper (high vacuum side) cooling water connection with a hose clamp.
- ➔ Connect return line to the lower cooling water connection on the turbopump.
- ➔ Tighten all hose clamps and check for tight fitting of the hoses.



Interchanging of cooling water feed and return will reduce the maximum motor power available (see Chapter. 4.11.).

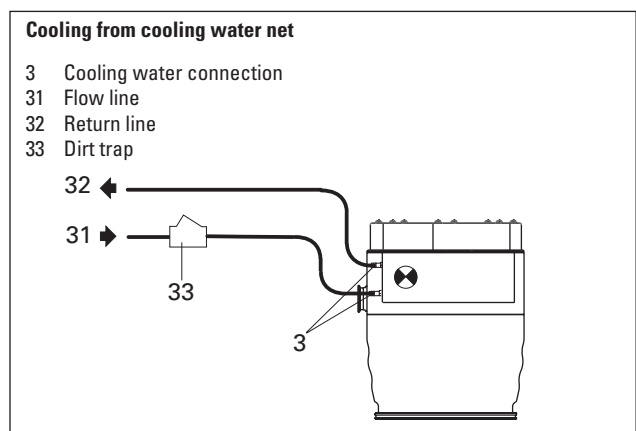

#### Cooling with Recycled Water Cooling Unit TZK (accessory)

A dirt trap in the lines is not permissible.  
 All remaining steps as described for connection of cooling water net.

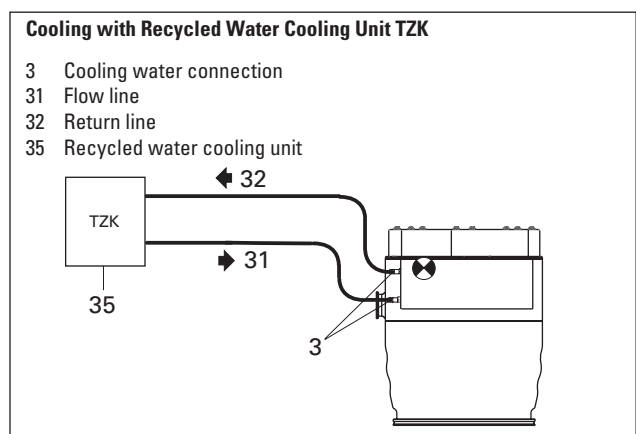

### 3.5. Electronic Drive Unit And Magnetic Bearing Controller TM 3000

#### General Unit Description

The Electronic Drive Unit And Magnetic Bearing Controller TM 3000 is always used in combination with the turbopump and form a single unit. All functions necessary to operate the turbopump are preprogrammed on delivery. The factory settings can only be changed via the RS 485 serial interface (DCU/HPU or PC). When the power supply is switched on, the pump is ready for operation. The operating mode is indicated through three LEDs at the Magnetic Bearing Controller TM 3000 (see Section 7.).

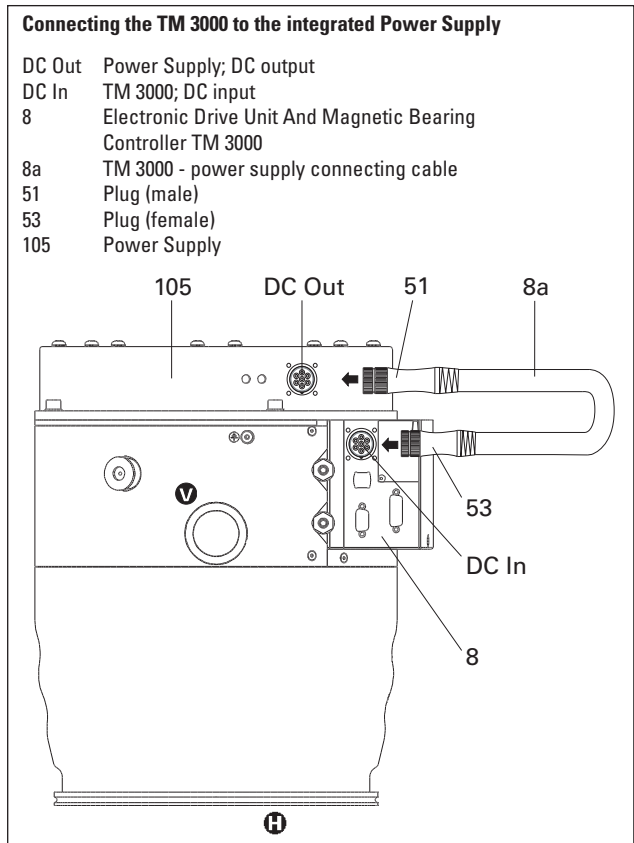
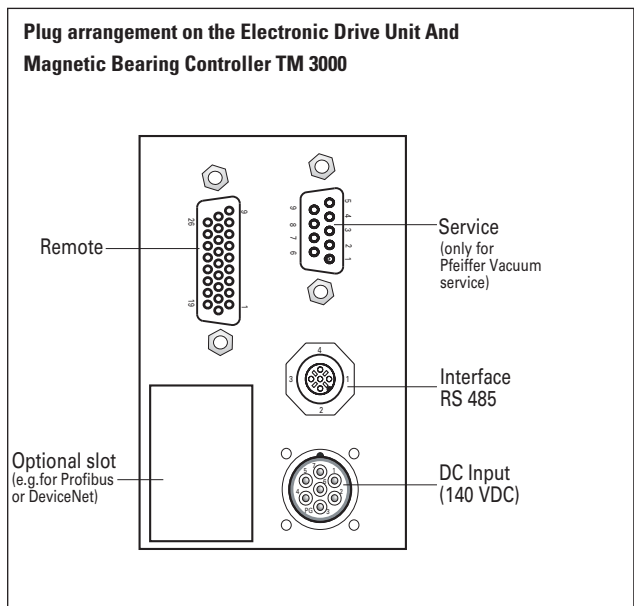

### Connecting the TM 3000 To The Integrated Power Supply



Make sure that the power supply is completely disconnected from the mains during electrical connection.



For supply disconnect, it is required to power the pump via a lockable main circuit breaker or switch rated 12A minimum, with a minimum ampere interrupting capability of 5000 AIC.



Pump, TM 3000 and power supply do not have an emergency-stop device. Make sure that they are properly included in the emergency stop system of the higher-level equipment control.

The connecting cable for the TM 3000 and the power supply is included with the delivery (length 0.30 m) and needs to be connected as follows. As a precaution please check that the grub screws are far enough unscrewed from the nut before connecting the cable.

- ➔ Insert plug 53 at the connecting cable 8a into the connection DC In at the TM 3000 and screw tight.
- ➔ Connect plug 51 at the connecting cable 8a to the power supply at the connection "DC Out" and screw tight.
- ➔ To ensure the protection class IP 54 of the connection the cap nuts of the plugs 51 and 53 must cover the o-rings of their counterpart completely.
- ➔ Secure the plugs 51 and 53 with the grub screws present.

#### Pin configuration mains connection, AC Input

- 1 Mains connection, phase L
- 2 Neutral line N
- 3 not connected
- PE Protective earth, PE

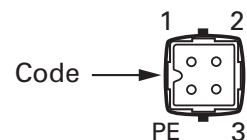

- ➔ Plug mains connection cable into mains connection "AC In" of the power supply and lock with the clamp.



The mains connection must be freely accessible at all times.



The TM 3000 will perform a self-test and calibrates the magnetic bearing sensors when the operating voltage is connected. During the self-test sounds from the sensor calibration can occur. After that the turbopump is ready to operate. The supply voltage for the turbopump is 140 VDC  $\pm 3\%$  as per the EN 60 742 standard.

### 3.6. Connecting The Venting Valve And Sealing Gas Valve

The venting valve and the sealing gas valve form a single unit. They are a standard component of the turbopump and they are delivered already mounted and connected. The inlet is a shared DN 10 ISO-KF small flange connection.



Permissible pressure on the venting valve:  
3 bar absolute.

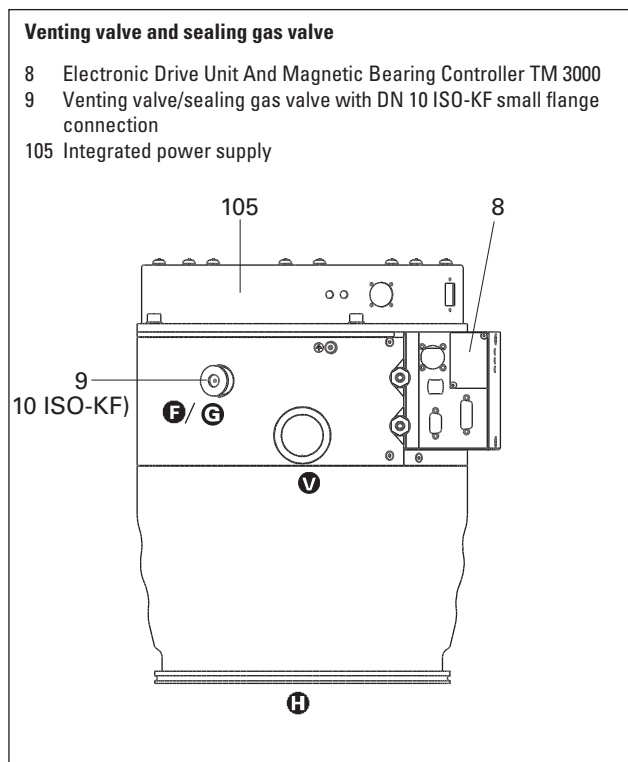

### 3.7. Connecting The Remote Control

Remote control options are accessible for various functions via the "REMOTE" connection on the TM 3000 using a 26-pin D-Sub (high density).

A screened cable should be used. The screen should be placed on the plug housing.

A distinction is made between digital and analog inputs and outputs.

#### Digital Inputs

Inputs adjusted to the level of SPS controls  
Logic 0 = Function OFF  $\Rightarrow$  level (-33 V to +7 V)  
Logic 1 = Function ON  $\Rightarrow$  level (+13 V to +33 V)

#### Digital Outputs

Potential-free relay contacts or active outputs  
(see "Plug Arrangement REMOTE" table)

#### Analog Inputs and Outputs

(See "Plug Arrangement REMOTE" table).

#### Pin Arrangement and Remote Plug Function

(See "Plug Arrangement REMOTE" table)

The active outputs deliver a signal of between 0 and 24 VDC and can handle current loads  $\leq$  50 mA.

An external relay can be connected to the active switching outputs 1 and 2 between Pin 8  $\Leftrightarrow$  Pin 26 and Pin 9  $\Leftrightarrow$  Pin 26.

Pin 26 is the complete mass GND\* (see "Plug Arrangement REMOTE" table).

## Plug Arrangement REMOTE

Pin	Description/Explanation	Function	Type
1	+ 24 VDC	Reference voltage for all remote inputs and outputs (potential free)	-
2	Venting release ON/OFF	Release "vent pump" The pump is vented according to the "Vent mode P030" setting	Digital input (static signal)
3	Motor TMP ON/OFF	Switches the turbopump drive on (is only switched on if the function "pumping station P010" is also ON)	Digital input (static signal)
4	Pumping station ON/OFF	Switches on pumping station (rotor lifted from its rest position. When [P:023] "Motor TMP" is set to ON, the rotor accelerates.)	Digital input (static signal)
5	Standby rotation speed ON/OFF	Rotor speed is limited to n% as per [P:717] (factory setting 66%)	Digital input (static signal)
6	not occupied		
7	Rotation speed preset 0-10 VDC	Rotation speed preset value in the range of 50-100% of the "nominal rotation speed" [P:315]	Analog voltage input 5-10 VDC; 0-5 V=f <sub>nom</sub>
8	Switching output 1 (Switch point)	Function configurable with «024:Conf. Out1»; factory setting [P:701] "rotation speed switch point" exceeded	Active digital output (I <sub>max</sub> = 50 mA/24 V)
9	Switching output 2 (error)	Function configurable with «019: Conf.Out2»; factory setting "error output 24 V = no error"	Active digital output (I <sub>max</sub> = 50 mA/24 V)
10	Sealing gas ON/OFF	The sealing gas valve is switched directly.	Digital input (static signal)
11	Backing pump control	24 V = Backing pump on	Active digital output (I <sub>max</sub> = 50 mA/24 V)
12	Uf/Ui/Up voltage output	Output voltage 0-10 VDC proportional; Rotor speed, motor current or drive power configurable with «055: Conf A01»	Analog voltage output 0-10 VDC / R <sub>L</sub> > 10 kΩ
13	Malfunaction acknowledgment	Deleting an error message	Digital input (pulse 500-1000 ms)
14	Remote priority ON/OFF	Remote functions have priority over operation via RS 485. Must be activated with parameter [P:028]	Digital input (static signal)
15	Relay contact switch point	Pin 15 and 16 connected when the rotor speed is above switch point	Relay contact U <sub>max</sub> = 50 VDC
16	Relay contact Switch point	Pin 16 and 17 connected when rotor speed is below switch point	I <sub>max</sub> = 1 A
17	Relay contact Switch point		
18	Relay contact Error	Pin 18 and 19 connected if there is no error	Relay contact U <sub>max</sub> = 50 VDC
19	Relay contact Error	Pin 19 and 20 connected if there is an error	I <sub>max</sub> = 1 A
20	Relay contact Error	(For additional information see Section 4.21. Switching Outputs)	
21	Relay contact Message	Pin 21 and 22 connected Value above limit value	Relay contact U <sub>max</sub> = 50 VDC
22	Relay contact Message	Pin 22 and 23 connected Value below limit value	I <sub>max</sub> = 1 A
23	Relay contact Message		
24	Relay contact Warning	Pin 24 and 25 connected if there is no warning	Relay contact U <sub>max</sub> = 50 VDC
25	Relay contact Warning		I <sub>max</sub> = 1 A
26	GND*	Ground potential for all remote inputs and outputs (potential free)	

### 3.8. Connecting The Serial Interface. Using A DCU Or HPU

#### Electrical Connection

The "RS 485" connection on the TM 3000 can be used to connect an operating component (DCU 001 or HPU 001) with a screened 5-pin connecting cable in a point to point connection **or** – using a level converter (TIC 001) – via a computer (PC).

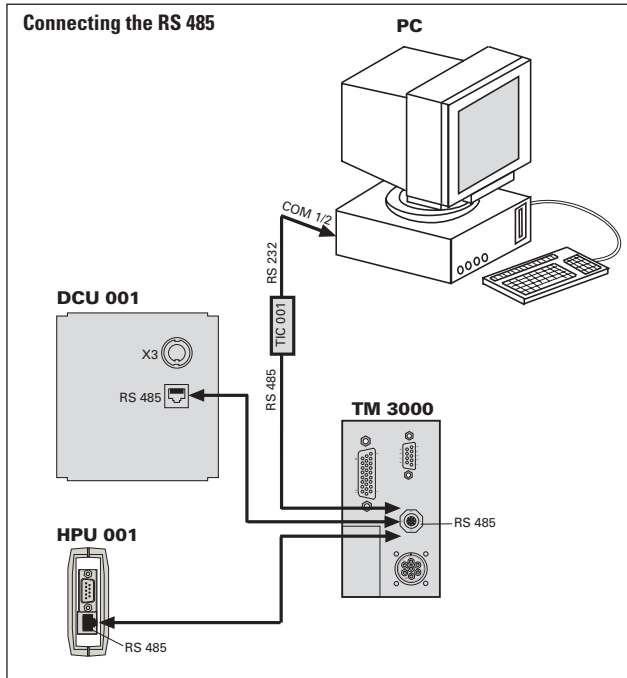

The interface is safely electrically isolated from the maximum supply voltage occurring in the TM 3000.

#### Data transfer format

Description	Value
Interface type:	RS 485
Baud rate:	9600 baud
Data word length:	8 bit
Parity:	No parity
Start bits:	1
Stop bits:	1..2

#### RS 485 plug arrangement

Pin	Arrangement
1	RS 485: D+ (D <sub>O</sub> / R <sub>I</sub> )
2	+24V output (≤ 210 mA loading capacity)
3	Gnd
4	RS 485: D- (D <sub>O</sub> / R <sub>I</sub> )
5	not connected

RS 485

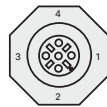

1 ... 4

(view from the plug side of the TM 3000)



An RS 232 (e.g. PC) can be connected via a TIC 001 level converter (see Section 12. Accessories).

### Bus Operation Via RS 485 Interface



Only one master can access the slaves in bus mode.

#### Connection to a fixed bus system:

- ➔ Connect all devices with D+ (Pin 1 / RS 485) and D- (Pin 4 / RS 485) to the bus.
- ➔ The bus must be closed at both ends.

The R<sub>T</sub> connections and bus connections should meet the RS 485 interface specifications.

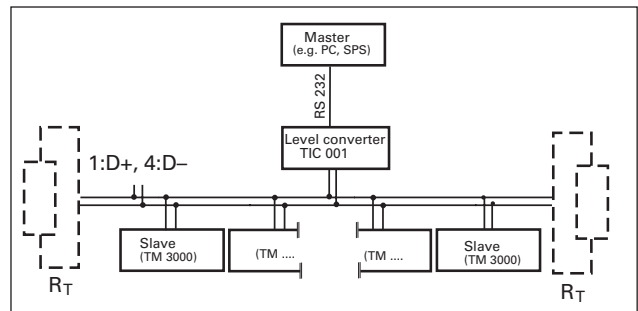

All devices connected to the bus must have different interface addresses [P:797].

The TM 3000 group address is 940.



Only safe low voltages can be connected to the RS 485 serial interface. Pin 2 (+24V output) cannot be connected.

All remote functions switched on have priority over the interface functions if [P:028] is set to "0".



Detailed information regarding operation via the RS 485 interface and the electrical data can be found in the separate Operating Instructions PM 0488 BN.

### 3.9. Connections Diagram

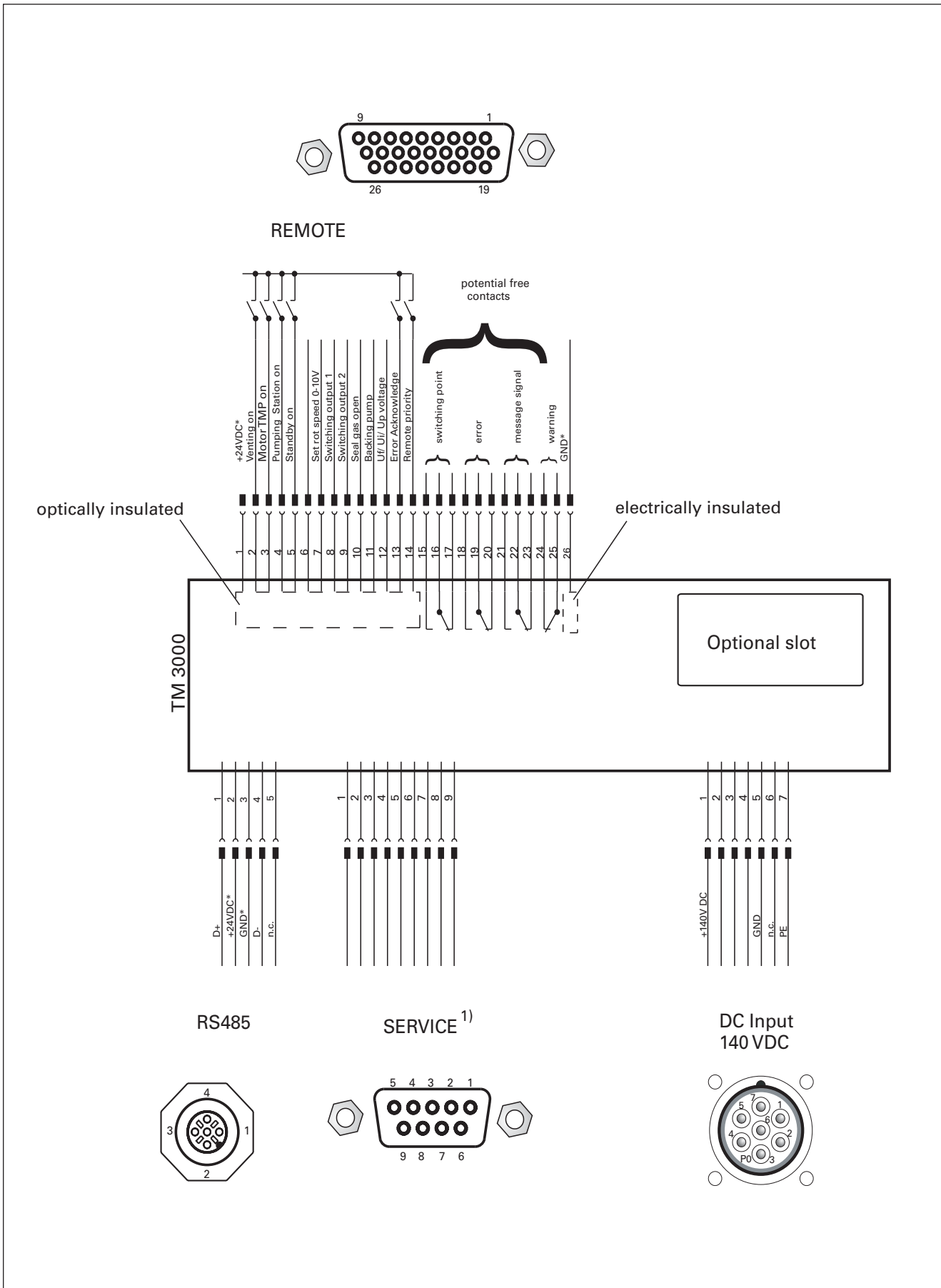

1) Only for Pfeiffer Vacuum Service.

## 4. Operations

### 4.1. General Operating Information

Magnetic bearings are non-wearing but have limited load capacity. Therefore, the HiMag™ 2400 is equipped with dry running safety bearings, which prevent contact between the rotor and stator in the event of strong vibrations, rapid high pressure changes, power failure and magnetic bearing defects. The safety bearings are subject to wear. To achieve the longest possible life for the safety bearings, you are urged to observe the following:

- Do not expose the pump to shocks, vibrations or other movements during operation. In particular, tilting of the pump causes contact between the rotor and safety bearings.
- Do not expose the pump to sudden pressure changes on the high vacuum or fore vacuum side during operation.
- Never stop the pump by turning off the mains voltage.

### 4.2. Operating Modes

#### RS 485 Serial Interface

The turbopump can be operated using the Display And Control Units DCU 001 or HPU 001, or using a PC via the RS 485 interface (see also Section 3.8.).

The procedure is described in the accompanying operating instructions (see Section 12. Accessories).

#### Bus operation via RS 485 Interface

The group address for the Magnetic Bearing Controller TM 3000 is 940. This address allows you to simultaneously transfer control commands or reference value inputs to all TM 3000 units. In this case, the TM 3000 units do **not** send reception acknowledgement to the master via the data bus. A description of the data communication can be found in the PM 0488 BN operating instructions.

#### Remote control operation

(see Section 4.18.)

### 4.3. Before Switching ON



The turbopump rotor rotates at high speeds. An open high vacuum flange can lead to injury and carries the risk of destroying the pump through objects falling into the pump.

Therefore never operate the pump with an open high vacuum flange.



Exercise care when pumping hazardous gases! Observe all safety recommendations from the gas manufacturer!

- ➔ For sealing gas operation: Sealing gas supply open.
- ➔ Open cooling water inlet and monitor flow.

The following **important** factory settings are programmed on delivery in the turbopump and can only be changed via the

RS 485 serial interface:

[P:700]	Starting time	15 min
[P:701]	Rotation speed switch point	80%
[P:030]	Automatic venting	0
[P:707]	Rotation speed set value in rotation control operation	50%
[P:717]	Rotation inputs in standby operation	66,7%
[P:797]	Unit address	1
[P:050]	Sealing gas	off
[P:027]	Gas mode	0

### 4.4. Switching ON

➔ The turbopump is ready to operate by connecting the integrated power supply to the mains voltage.

If after applying the mains voltage the error message E777 is displayed, then proceed as follows:

- ➔ In the case of the DCU 001 or HPU 001 select «777: PumpRot Max».
- ➔ Enter the nominal speed for the connected pump once (see Section 11. Technical Data).

The error message E777 is erased, the pump is ready for operation.



This procedure is part of a redundant safety system for avoiding excessively high speeds.

- ➔ Switching on with one operating mode as described in section 4.2.
- After the self-test of the drive has been completed successfully, the rotor of the turbopump begins to rotate.
- After the self-test has been completed successfully (duration approx. 20 seconds), the turbopump goes into operation. During the self-test, you can hear sounds from the sensor calibration.

The rotation speed switch point [P:701] must be reached within the preset startup time [P:700].

If the rotation speed switch point is not reached in this time, the turbopump is shut down. The red LED lights up (aggregated error message).

After malfunction acknowledgment, the startup time is reset to the initial value and the rotor is accelerated again.

## 4.5. Normal Operation Of The Turbopump

The turbopump is started up with maximum drive power. When the set rotation speed [P:315] is reached, the pump is switched to rotation speed control and the motor current [P:310] is set to a value dependent on the gas throughput and fore-vacuum pressure.

## 4.6. Standby Rotation Speed ON/OFF

- ➔ Select «002:Standby» with DCU 001/HPU 001.
- ➔ Select «OFF» or «ON».

“Standby mode” means operation of the turbopump at 66.7% of the final rotation speed [P:315] (factory setting). This value can be changed as follows:

- ➔ Select «717: Stbyrotset»
- ➔ Set standby rotation speed in the range 50-100%.

The standby function can be activated via remote control or the serial interface.

Standby mode is not possible in rotation speed set mode ([P:023] “ON”) (see Section 4.7.).

## 4.7. Turbo Drive ON/OFF

The rotor drive can be turned on and off separately via the DCU 001/HPU 001 during operation of the pumping station :

- ➔ Select «023: Motor TMP».
- ➔ Select« OFF» or «ON».

The rotor accelerates to the nominal rotation speed or shuts down.

## 4.8. Rotation Speed Switch Point

The calculation of the rotation speed switch point always relates to the set rotation speed [P:308].

It is influenced by the settings of the parameters

[P:002] “Standby”  
[P:717] “Stbyrotset”  
[P:026] “OpMode TMP”  
[P:707] “TMProt set”

and the remote analog input Pin 7 “Set rot speed 0-10 V”.

The following always applies:

Rotation speed switch point [Hz] =  $\frac{[P:308] \cdot [P:701]}{100}$

## 4.9. Rotation Speed Set Mode

The rotation speed set mode is selected if the gas throughput of the turbopump is to be modified. The pressure ratio and pumping speed of the pump fall with the rotation speed.

### Rotation speed preset in rotation speed set mode

- ➔ Select «707: TMProt set» with DCU 001/HPU 001.
- ➔ Set rotation speed in the range of 50-100%.

### Operating mode of the turbopump

- ➔ Select «026: OpMode TMP» with DCU 001/HPU 001.
- ➔ Select «1» for rotation speed set mode.



Standby mode is ineffective in rotation speed set mode. Rotation speed set mode can also be set and activated via remote control or the serial interface.

## 4.10. Backing Pump Operation

The “remote” output Pin 11 can be used for drive control a backing pump.

The backing pump is switched on or off at the same time with the turbopump using «010: Pump stat».

The backing pump also is switched off when turbopump errors occur.

## 4.11. Gas Type Dependent Operation

With high gas loads and high rotation speeds, gas friction causes the rotor to heat up. To prevent overheating, a power-rotation speed characteristic is implemented in the TM 3000, which allows the pump to be operated at any rotation speed with the maximum permissible gas load with no risk of damage. The maximum power will depend on the type of gas and cooling power available. In order to fully utilise the power of the pump irrespective of the type gas, two characteristics are available.

«027: Gas Mode» (selectable with DCU001/HPU 001)

- “Gas Mode 0” for gases with molecular mass  $\geq 40$  such as argon (factory setting);
- “Gas Mode 1” for all lighter gases.



Pumping gases with a molecular mass  $\geq 40$  in the incorrect gas mode can damage the pump. When pumping noble gases heavier than Argon it can come to the destruction of the pump. Please contact the manufacturer before using such gases.

The rotor is always accelerated with maximum drive power when the turbopump is started up in order to minimize the start-up time. After the set rotation speed is reached, it switches automatically to the selected power characteristic. If the gas type dependent drive power is exceeded, the rotor speed is reduced until equilibrium between the permissible power and the gas friction is reached. To avoid fluctuations in the rotation speed, we recommend setting an equilibrium frequency or a somewhat lower frequency in rotation speed set mode.

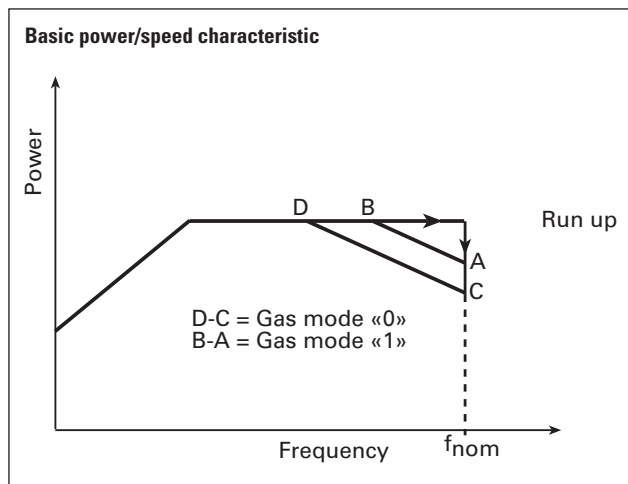

### Measurement of the cooling surface temperature

The temperature of the cooling surface «323: T\_Clg plate» is measured in the TM 3000 in the vicinity of the cooling water supply connection. The measured value is utilised directly in the calculation of the current maximum motor power.

From the motor power and the in each case prevailing forevacuum pressure, the maximum gas throughput can be taken from the following diagrams:

### Gas type characteristics lines “Gas Mode 1”

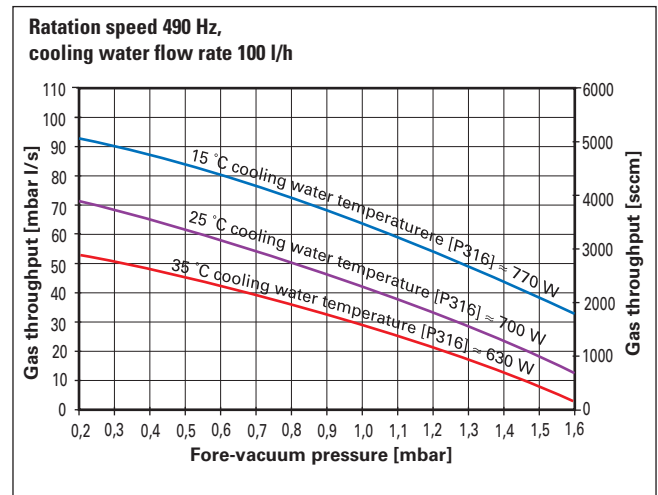

### Gas type characteristics lines “Gas Mode 0”

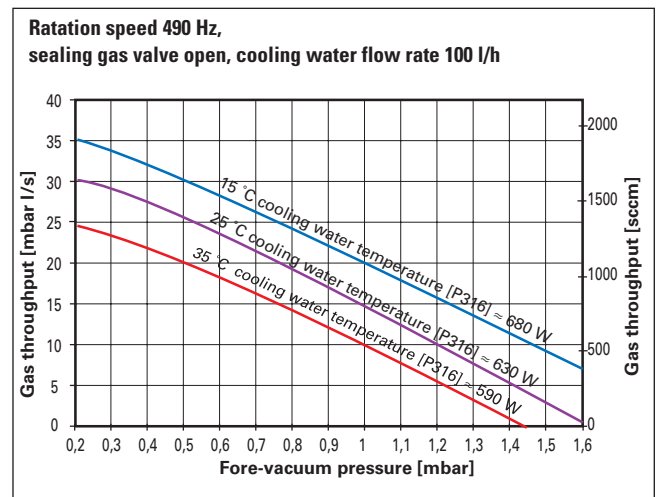

The indicated power characteristics lines apply only with opened sealing gas valve. The maximum power is reduced if the sealing gas valve is closed. With the sealing gas valve closed, the maximum power in “Gas Mode 0” is reduced by 20%.

In the event of gas throughput changes, the system will attain new temperatures after a transitional period. During this transitional period, the maximum gas throughput is different compared to the steady state. In particular, in the case of a cold pump it will be possible to pump briefly a higher gas throughput compared to continuous operation.

During operation close to the respective limits, a speed drop of 2-3 % may occur. This is absolutely normal and is not indicative of a fault.



Due to the distance between the cooling water and the point of the measurement for the cooling surface temperature, the difference of the two temperature values may amount to approximately 12° C, especially at high driving powers.

## 4.12. Switching Off And Venting

To prevent contamination of the turbopump after switching off, the pump should always be vented before shut-down (see also Section 4.19. Vent Modes).

Only dry gases can be used for venting. Avoid humidity in the pump as it can affect the corrosion protection of the rotor coating.



Uncontrolled venting can lead to overloading of the axial bearing and require use of the safety bearing.

The HiMag™ 2400 can only be vented using the pre-mounted venting valve. This cannot be replaced by other venting equipment.

Maximum pressure of the venting valve: 3 bar absolute.

If a higher venting rate is required, additional venting equipment can be opened as soon as the rotation speed of the pump is less than 100 Hz.

In this case, the venting valve on the turbopump must be opened **first** so that no process gas gets into the motor chamber.



We do not recommend venting above atmospheric pressure, otherwise there is a risk when opening the system and a risk of leakages.

If the pump is to be vented with equipment other than that installed from the outset, the pressure rise on the HV flange must be limited to 0.5 mbar/s until the rotation speed is less than 100 Hz.

### Switching OFF

- ➔ Switch off the turbopump and backing pump together, e.g. via Remote / Pin4.



With corrosive gas processes, the seal gas supply shall be closed and the fore-pump switched off only when no more corrosive gas is in the pump. Our recommendation is to maintain the purge gas feed and the operation of the HiMag™ 2400 and the fore-pump for an appropriate time period after the end of the purge gas feed.

- ➔ After the rotation speed has reached 0 Hz, disconnect the power supply from the mains. Since the turbopump, magnetic bearing controller and power supply have no lock-out/tag-out device, only disconnecting the power supply completely from the mains puts the system in a safe condition.



Wait at least one minute if the connection cable between power supply and TM 3000 is to be removed. Otherwise, there is the danger of an electric shock.

- ➔ Close the water supply.



Hot surfaces cool off very slowly. To accelerate the cooling process, the cooling water should have a follow-up-time.

### Electrical brake

When shutting down the turbopump without venting, with an electrical brake the rotor can be braked rapidly from the rated rotation speed to 0 Hz.

- ➔ Set «013: Brake enab» to «1».

The activation of brake and venting is independent on each other.

## 4.13. Emergency Stop

In case of an emergency stop, the pump shall be stopped according to chap. 4.12, preferably with venting the pump and using the electrical brake.

After standstill, the power supply must be disconnected from the mains. If stopping the pump regularly should not work, the power supply can be disconnected from the mains regardless of the rotor speed. In both cases, the main circuit breaker or switch in the higher-level equipment must be locked and it must not be possible to unlock unless the cause is corrected and the fault is cleared.

#### 4.14. Safety Bearings

During strong external vibrations or improper operation, the rotor is supported by dry running safety bearings (see also Section 4.1.).

The safety bearings are subject to wear. The current wear status [P:329] "Bearg Wear" as a % of the maximum wear can be accessed via the DCU 001 or HPU 001.

Different events can cause different degrees of safety bearing wear. These are assessed as follows:

Event	Safety bearing stress	Share in wear per event
Power failure with the rotors running into the safety bearings	low	0.2 %
Uncontrolled venting with overloading the magnetic bearings	medium	2 %
Impacts with safety bearing contact, rotor is stabilised again	medium	1 %
Running down of the rotor in the safety bearings	high	5 - 10 % <sup>1)</sup>

<sup>1)</sup> depending on the speed at the beginning of the contact with the safety bearings

At a level of 75 % the warning F890 is output, from 100 % onwards the error message E890 is output and operation of the pump will no longer be possible.

To repair the turbopump, please contact your nearest Pfeiffer Vacuum Service Center.

#### 4.15. Monitoring Of The Balancing Condition

The current balancing condition of the rotor is constantly monitored through sensors on the magnetic bearings. The balancing condition can be queried through DCU 001 or HPU 001 under [P:358] "UnBal Ch\_A" and [P:359] "UnBal Ch\_B" for both radial bearing planes in percent of the maximum permissible imbalance. If the value in at least one of the planes reaches 75 % or more, then the warning F891 will be output. From 100 % onwards, the error message E891 will be output and the pump will be shut down.

#### 4.16. Emergency Power Operation

If the power supply fails during operation of the turbopump, the pump motor works as a generator and supplies the power for the electronics.

The power failure is indicated by a flashing signal of the green LED on the housing on TM 3000.

The turbopump energy is insufficient to run the magnetic bearing at a rotor speed below approximately 50 Hz. The Magnetic Bearing Controller TM 3000 is shut down completely and the rotor winds down in the safety bearings.

Once power returns, the turbopump automatically restarts at the set rotation speed.

If a mains power failure occurs while the pump is running down with the electric brake active, this condition cannot be detected by the controller and is therefore not indicated. Otherwise the system will behave in the same way as in the case of a mains power failure during normal operation, but the system will not run up automatically as soon as the mains power returns.

#### 4.17. Shut Down For Longer Periods



If aggressive or hazardous gases are pumped occasionally, there is a risk of injury from contact with process gases. Before removing the turbopump from the system, first:

- Vent the turbopump with inert gas or dry air;
- Ensure that no process gases remain in the system or supply lines.

If the turbopump is to be shut down for longer than one year:

- ➔ Remove the turbopump from the system.
- ➔ Close the high vacuum flange and evacuate the turbopump using the fore-vacuum flange.
- ➔ Vent the turbopump with dry air or nitrogen via the venting connection.
- ➔ Close the fore-vacuum and vent connections with blank flanges.
- ➔ Place the pump in a vertical position.
- ➔ The pump must be stored in buildings within a temperature range of -25 °C to +55 °C.
- ➔ In rooms with a humid or aggressive atmosphere: Seal the pump in an airtight synthetic bag with a bag of drying agent.

## 4.18. Remote Control Operation



If power failure occurs during operation, the turbopump automatically restarts once power returns.

The following functions can be controlled using remote control (see also "Plug Arrangement REMOTE" table):

- Heating ON/OFF
- Standby rotation speed ON/OFF
- Pumping station ON/OFF
- Motor TMP ON/OFF
- Vent release ON/OFF
- Sealing gas ON/OFF
- Remote priority ON/OFF
- Rotation speed input (50-100% of the nominal rotation speed [P:315] corresponds to 5 - 10 VDC voltage)
- Malfunction acknowledgment

### Operating Modes With Remote Control

There are three different options for remote control with different priorities for the functions:

#### Standard remote control

- ➔ Set «028: Opmode Rem» to «0».

The digital switching functions are activated through "SPS High level" <sup>1)</sup>.

Activated individual functions cannot be changed via the interface. Individual functions deactivated with remote control can be operated using the interface.

→ The settings are saved.

1) SPS-High level:	+13 V bis +33 V
SPS-Low level:	-33 V bis +7 V
Ri:	7 kΩ

#### Remote control priority "ON"

For certain applications, such as SPS control, the remote control functions can be set to have priority.

- ➔ Set «028: Opmode Rem» to «1», prepare priority function
- ➔ Set connection between Pin 1 and Pin 14 to "remote" or "SPS high".

The priority for remote control is now active.

The unit can now only be controlled via "Remote".

Equivalent functions can no longer be operated via the RS 485 interface.

→The settings are saved.

The following functions are activated with "SPS high level" and deactivated with "SPS low level":

- Motor TMP ON/OFF
- Heating ON/OFF
- Standby rotation speed ON/OFF
- Pumping station ON/OFF
- Vent release ON/OFF
- Sealing gas ON/OFF
- Malfunction acknowledgment

#### Remote control priority "OFF"

➔«028: Opmode Rem» remains set to «1».

➔ Set Pin 14 to "SPS low" on remote or connect to Pin 26.

→ Operation only possible via interface (remote control inactive).

→ Set values are saved.



Remote Pin 7 "set rotation speed preset" always has priority when there is a voltage signal in the range 5 - 10 VDC.

## 4.19. Vent Modes

Venting is only possible after turning off the pumping station.  
**[P:010]** Pumping station "OFF"

The venting valve is closed without current. In case of error, the pump is vented in accordance with the selected vent mode.

Three vent modes can be selected using the DCU 001 or HPU 001:

- ➔ Select «**012: Vent enab**»; Select «**ON**», release vent mode.
- ➔ Select «**030: Vent mode**»; Select «**0**», «**1**» or «**2**».

### Venting mode «0»: Automatic venting

Automatic venting means that venting begins when pumping station is "OFF" **[P:010]**, in case of power failure or error.

Venting occurs below a set rotor speed **[P:720]** for a set duration **[P:721]** after an additional delay of 6 seconds. During this time, a high vacuum valve can be closed if installed.

The venting valve closes when the pumping station is turned on, **[P:010]** pumping station "ON".

The set duration cannot be guaranteed in case of power failure.

- ➔ Select «**720: Vent freq**»
- ➔ Rotor speed between 40-80% of the final rotation speed **[P:315]** selectable.
- ➔ Select «**721: Vent time**»
- ➔ Set venting duration in seconds between 6 and 3600.

### Venting mode «1»: Venting OFF

→ The pump is not vented.

### Venting mode «2»: Venting ON

→ If "Pumping station OFF" **[P:010]** or in case of error, the pump is vented after a delay of 6 s. During this time, an available high vacuum valve can be closed. The venting valve closes when the pumping station is switched on, **[P:010]** pumping station "ON".

## 4.20. Configuration Of The Analog Output

An analog signal (0-10 V DC) can be received on "Remote" Pin 12 with the following information:

- Rotation speed of the turbopump or
- Drive power or
- Motor current

The analog output must be configured according to its function.

➔ Select «**055: Conf A01**»

➔ Select funktion «**0**», «**1**» oder «**2**»:

- 0 = Rotation signal, 0 - 10 VDC  $\Rightarrow$  0 - 100 %  $\cdot f_{end}$
- 1 = Power signal, 0 - 10 VDC  $\Rightarrow$  0 - 100 %  $\cdot P_{max}$
- 2 = Current signal, 0 - 10 VDC  $\Rightarrow$  0 - 100 %  $\cdot I_{max}$

## 4.21. Switching Outputs

The following functions are assigned to the switching outputs:

**Switching output 1:** (Remote: **Pin 8** and **relay contact switch point**)

Active high after rotation speed switch point is reached.

The turbopump switch point is factory set to 80 % of the set rotation speed **[P:308]**. For example, it can be used for a "Pump Ready" message.

**Switching output 2:** (Remote: **Pin 9** and **relay contact error**)

The output function can be configured using the parameter «**019: Conf. OUT2**».

<b>[P:019]</b>	<b>Remote Pin 9</b>
0 (factory set)	low: in case of error, power off high: unit ready for operation
1	low: in case of error, warning or power off high: unit ready for operation
2	low: in case of error, power off or drive off <b>[P:023]</b> high: Pump in operation

## 5. Error Messages And Warnings



Error messages and warnings can only be displayed by the Display And Operating Units DCU 001 or HPU 001.

### 5.1. Error Messages / Status Messages



Errors ("Exxx") will always switch off the turbomolecular pump and the connected components.

- ➔ After having remedied the fault run the fault acknowledging process.
- The turbopump is then again ready for operation.

Error	Description	Troubleshooting
E001	Rotor overspeed has been detected	Inform Pfeiffer Vacuum Service
E002	Power supply voltage TM 3000 defective	Check power supply; if required inform Pfeiffer Vacuum Service
E006	Run-up time error; After the run-up time has elapsed the speed of the pump has dropped below the speed switching threshold	Allow a sufficient run-up time, check forevacuum, check for temperature effects, check cooling arrangement
E015	Error affecting the controller for the magnetic bearing	Acknowledge fault; If required, reset computer through mains ON/OFF at 0 Hz; If required, inform Pfeiffer Vacuum Service
E021 – E043		Inform Pfeiffer Vacuum Service
E044	Overtemperature drive output stage	Check cooling arrangement for the pump; if OK, inform Pfeiffer Vacuum Service
E045	Overtemperature motor	Check cooling arrangement for the pump; if OK, inform Pfeiffer Vacuum Service
E089	Rotor outside its nominal position; stabilisation not possible	Avoid impacts and vibrations; check stiffness of the pump mounts
E098	Error affecting internal communication	Inform Pfeiffer Vacuum Service
E777	Parameter [P:777] not set to the final speed of the connected pump	Set [P:777] to final speed of the pump; see Chapter. 4.4.
E800 – E810		Inform Pfeiffer Vacuum Service
E811	Rotor deflection unacceptably high	Avoid impacts and vibrations; check stiffness of the pump mounts

Error	Description	Troubleshooting
E812	Position error affecting the magnetic bearing	Renewed pump calibration by switching the mains OFF/ON; should this reoccur, inform Pfeiffer Vacuum Service
E814	Error affecting the drive sensors	Acknowledge the fault; should this reoccur, inform Pfeiffer Vacuum Service
E815	Error affecting the magnetic bearing amplifier defective or shorted line section	Inform Pfeiffer Vacuum Service
E816	Error overtemperature controller	Avoid exposing the TM 3000 to thermal radiation; if required, inform Pfeiffer Vacuum Service
E817	Status message; Mains power has returned while rotor was running on the safety bearings	Rotor is slowed down to a standstill; thereafter a sensor calibration is run and renewed run-up. No further activities are required
E819	+24 V overvoltage	Inform Pfeiffer Vacuum Service
E820/ E058	Error overtemperature cooling plate E820 = Sensor defective (interrupted)	Check cooling arrangement for the pump, if OK, inform Pfeiffer Vacuum Service
E821 – E824		Inform Pfeiffer Vacuum Service
E825	Error redundant speed measurement system	Should this reoccur, inform Pfeiffer Vacuum Service
E890	safety bearing wear > 100 % Pfeiffer Vacuum Service	In order to have the safety bearings replaced, inform
E813	Error rotor unbalance	Inform Pfeiffer Vacuum Service
E913 <sup>1)</sup>	Direction of rotation fault	The fault will reset itself. <b>Caution!</b> The pump will try to start up automatically on its own. Should this happen several times, check to see if the rotor can rotate freely. If required, inform Pfeiffer Vacuum Service.

1) The error message is not indicated via switching output 2 (collective fault message)

## 5.2. Warnings

Warnings (“Warning Fxxx”) are indicative of functional restrictions or indicate the following faults.

Es kann zum Abschalten von Komponenten kommen.

Components may be switched off in the case of warnings.

Number	Description	Explanation/troubleshooting
F001	TMS warmup time has elapsed	Check heating cartridges; check TMS
F002	TMS temperature limit has been reached	Check cooling arrangement; check ambient temperature
F007	Low voltage from power supply TM 3000	Check mains voltage, check power supply
F011	Realtime clock malfunction	Pump is operational; will cause the touchdown bearing wear counter to malfunction; remedy the fault as soon as possible. Inform Pfeiffer Vacuum Service
F024	Sealing gas valve	Sealing gas valve defective or connection defective
F044	High temperature warning for the drive output stage	The warning level has been set 5° K below the overtemperature shutdown threshold. Drive power is linearly reduced. Check cooling arrangement
F045	High temperature motor warning	The warning level has been set 10° K below the overtemperature shutdown threshold. Check cooling arrangement
F046	Malfunction affecting data channel to EEPROM	Inform Pfeiffer Vacuum Service
F051	Venting valve	Venting valve defective or connection defective
F058	High temperature cooling plate warning	The warning level has been set 5° K below the overtemperature shutdown threshold. Check cooling arrangement
F089	Rotor vibrations	Avoid impacts and vibrations; check pump mount; check stiffness of the pump mount
F600	Fault affecting the control unit	Should this reoccur, inform Pfeiffer Vacuum Service
F801	Brake chopper defective	Pump is operational; brake operation not possible; if required inform Pfeiffer Vacuum Service
F805	+24 V low voltage	Inform Pfeiffer Vacuum Service
F806	Overvoltage in intermediate circuit. (brake current goes to 0 A)	Pump is operational; brake operation not possible; if required inform Pfeiffer Vacuum Service
F816	Warning high temperature in the electronics	The warning level has been set 5° K below the overtemperature shutdown threshold, check cooling arrangement. Avoid exposing the TM 3000 to thermal radiation
F890	Safety bearing wear > 75 %	Plan for a safety bearing replacement; pump will be shut down as soon as 100 % is reached.
F891	Rotor unbalance > 75 %	Pump is operational; observe further development; pump will be shut down as soon as an imbalance of 100 % is reached.

## 6. Parameters

### 6.1. General

All turbopump or electronic drive unit and magnetic bearing controller variables relevant for its functioning are available in the form of parameters in the TM 3000. Each parameter has a number and a description, e.g. «026: OpMode TMP».

Factory settings can be retained or you can create your own settings under “Control Commands” and “Reference Value Inputs”. For details on using factory settings or changing the operating conditions, consult Section 4. Operation.

There are three different parameter types:

Parameter typ	Function
Setting commands	Usually change a basic setting, ON/OFF or numerical
Status requests	Deliver digital (on/off, 0/1, yes/no) and numerical information (readable only, cannot be changed)
Set points	Setting a numerical value















### 6.2. Setting Commands

(readable and writable)

#	Display		Name, Description	Unit	min	max	Factory setting	RS 485 1)	Data type <sup>2)</sup>
001	Heating		Pre-selection heating [ON/OFF]	-	OFF	ON	OFF <sup>3)</sup>	R/W	0
002	Standby		Standby ON/OFF	-	OFF	ON	OFF <sup>3)</sup>	R/W	0
004	RUTime		Starting time monitor [ON/OFF]	-	OFF	ON	ON	R/W	0
009*	Error ackn		Malfunction acknowledgment	-			-	-W	0
010	Pump stat		Pumping station [ON/OFF]	-	OFF	ON	OFF <sup>3)</sup>	R/W	0
012	Vent enab		Vent release turbopump [ON/OFF]	-	OFF	ON	OFF <sup>3)</sup>	R/W	0
013	Brake enab		Motor brake [ON/OFF]	-	OFF	ON	ON	R/W	0
019	Conf.OUT2		Configuration switching output K2 (also aggregated error output ) 0=open if “Power OFF” or error, 1=as 0 or warning, 2= open if “Power OFF”, “Turbo drive OFF” or error	-	0	2	0	R/W	7
023	Motor TMP		Motor turbopump [ON/OFF]	-	OFF	ON	ON <sup>3)</sup>	R/W	0
024	Conf.OUT1		Configuration of switching output K1 0=switch point reached signal	-	0	1	0	R/W	7
026	OpMode TMP		Operating mode turbopump 0=final rotation speed operation; 1=rotation speed operation	-	0	1	0 <sup>3)</sup>	R/W	7
027	Gas mode		Gas operating mode 0=heavy noble gas; 1=other gases	-	0	1	0	R/W	7
028	Opmode Rem		Operating mode drive unit 0=Remote/ISO/Key operation according to Pfeiffer Standard *1, 1=as 0 except remote inputs have priority if pin is set to remote control *1; *1:Remote2 interface command inputs without function	-	0	1	0	R/W	7
030	Vent mode		Vent mode 0=controlled venting, 1=never vent 2=continuous venting 6s after P010 venting station OFF	-	0	2	0	R/W	7
050	SealG Vlv		Sealing gas [ON/OFF]	-	OFF	ON	OFF	RW	0
055	Conf A01		Configuration analog output 1 0=Rotation speed proportional, 1=Drive power proportional 2=Drive current proportional	-	0	2	0	R/W	7

## 6.3. Status Requests

(readable only)









#	Display		Name, Description	Unit	min	max	Factory setting	RS 485 1)	Data type <sup>2)</sup>
300	Rem ctrlId		"REMOTE" function active	-	-	-	-	R-	0
302	Swpnt att		Rotation speed switch point reached	-	-	-	-	R-	0
303	Error code		Current error code	-	-	-	-	R-	4
304	Drv ovtemp		Excess electronics temperature	-	-	-	-	R-	0
305	TMP ovtemp		Excess pump temperature	-	-	-	-	R-	0
306	Rotspd Att		Set rotation speed reached ( $\pm 2\%$ )	-	-	-	-	R-	0
307	TMP Accel		Rotor accelerated	-	-	-	-	R-	0
308	Set rotspd		Set rotor rotation speed	Hz	0	1000	-	R-	1
309	Act rotspd		Actual rotor speed	Hz	0	1000	-	R-	1
310	TMP I-Mot		Turbo pump motor current	A	0.00	15.00	-	R-	2
311	TMP Op hrs		Turbo pump operating hours	h	-	65535	-	R-	1
312	PCS Softw		Control unit software version	-	-	-	-	R-	4
313	TMP DClink		Turbo motor intermediate circuit voltage	V	0.00	200.00	-	R-	2
314	DRV Op hrs		Electronics operating hours	h	0	65535	-	R-	1
315	TMP finspd		Permissible final rotation speed for connected turbopump rotor	Hz	0	1000	-	R-	1
316	TMP power		Current drive power	W	0	2000	-	R-	1
319	Cycl count		Cycle counter (counts switches from P010)	-	0	65535	-	R-	1
323	T Clg plate		Cooling surface temperature	°C	0	150	-	R-	1
329	Bearg Wear		Wear condition safety bearings	%	0	105	-	R	2
331	TMS ActTmp		TMS thermal temperature actual value	°C	5	510	-	R-	1
333	TMS steady		TMS temperature regulator set [Set value=Actual value] ( $\pm 2$ °K)	-	0	1	-	R-	0
334	TMS maxTmp		Maximum TMS thermal temperature measured	°C	0	510	-	R-	1
335	Heat Type		Heating type 0=Flange heater 1=TMS heater 2=Water cooling or nothing connected 255=Type not recognized	-	0	2	-	R-	7
346	TMPmotTemp		Motor temperature	°C	0	150	-	R-	7
349	Drv Name		Electronic drive unit type	-	-	-	TM 3000	R-	4
352	Drv Softw		Electronics software version	-	-	-	-	R-	4
357	CPLD Vers		Version magnetic bearing-CPLD	-	-	-	-	R-	4
358	UnBal Ch_A		Out-of-balance level A	%	0	150	-	R	1
359	UnBal Ch_B		Out-of-balance level B	%	0	150	-	R	1
360	Past Err1		Error memory, item 1 (last occurring error)	-	-	-	-	R-	4
361	Past Err2		Error memory, item 2	-	-	-	-	R-	4
362	Past Err3		Error memory, item 3	-	-	-	-	R-	4
363	Past Err4		Error memory, item 4	-	-	-	-	R-	4
364	Past Err5		Error memory, item 5	-	-	-	-	R-	4
365	Past Err6		Error memory, item 6	-	-	-	-	R-	4
366	Past Err7		Error memory, item 7	-	-	-	-	R-	4
367	Past Err8		Error memory, item 8	-	-	-	-	R-	4
368	Past Err9		Error memory, item 9	-	-	-	-	R-	4
369	Past Err10		Error memory, item 10	-	-	-	-	R-	4
380	MBSf 0_23		Statusinformation	-	-	-	-	R	4
381	MBSf 24_47		Status information	-	-	-	-	R	4
382	MBSf 48_71		Status information	-	-	-	-	R	4
383	MBSf 72_87		Status information	-	-	-	-	R	4
390	MBop 0_23		Status information	-	-	-	-	R	4
391	MBop 24_47		Status information	-	-	-	-	R	4
392	MBop 48_71		Status information	-	-	-	-	R	4
393	MBop 72_87		Status information	-	-	-	-	R	4

 The parameter value gets permanently stored.

- 1) R=Parameter is readable via the interface  
W=Parameter is writable via the interface
- 2) See interface description: "Pfeiffer protocol on R 232 / R 485", PM 0488 BN

## 6.4. Set points

(readable and writable)

#	Display		Name, Description	Unit	min	max	Factory setting	RS 485 1)	Data type <sup>2)</sup>
700	TMP RUTime		Maximum permissible starting time	min	1	120	15	R/W	1
701	Switch pnt	 <	Rotation speed switch point	%	50	90	80	R/W	1
704	TMSheatset		TMS thermal temperature setpoint	°C	30	90	40	R/W	1
707	TMProt set		Rotation speed setpoint in rotation speed control mode	%	20.0	100.0	50.0	R/W	1
717	Stbyrotset		Rotation input in standby mode	%	20.0	100.0	66.7	R/W	2
720	Vent freq		Venting frequency (for controlled venting P030)	%	40	80	50	R/W	7
721	Vent time		Minimum venting time (for controlled venting P030)	s	6	3600	15	R/W	1
777	PumpRotMax		Final rotation speed of the connected turbopump	Hz	0	3000	<sup>3)</sup>	R/W	1
797	Address		Device address, see interface description: "Pfeiffer protocol on RS 232/RS 485", PM 0488 BN	-	1	255	1	R/W	1



The parameter value gets permanently stored.

- 1) R=Parameter is readable via the interface  
W=Parameter is writable via the interface
- 2) See interface description: "Pfeiffer protocol on R 232 / R 485",  
PM 0488 BN
- 3) Preset to the connected turbopump

# 7. Monitoring The Operating Conditions

## 7.1. Operating Mode Display Via LED

You can read off specific operating conditions of the turbopump and TM 3000 using three LEDs in the front plate of the TM 3000.

The following operating conditions are displayed:

LED color	Continuously ON	Continuously ON for 2 s after supply voltage ON	Slow blinking 1/1 (500 ms/500 ms)	Slow flashing 1/12 (80 ms/920 ms)	Fast flashing 1/1 (80 ms/80 ms)	Fast flashing 1/1 simultaneously
<b>RED</b>	Aggregated error message; pump will be switched off	Function test		Aggregated warning message; pump will not be switched off		Programming factory setting active
<b>YELLOW</b>	Aggregated warning message; pump will not be switched off	Function test			Warning vibration	Programming factory setting active
<b>GREEN</b>	Pumping station [P:010] = "ON" and voltage supply OK	Function test	140 VDC no voltage supply (e.g. power failure)	Pumping station [P:010] = "OFF" and voltage supply OK		Programming factory setting active

### Integrated Power Supply

Using the two LEDs of the integrated power supply the following operating conditions are displayed:

LED color	ON	OFF
<b>RED</b>	Excess temperature power supply	Temperature power supply OK
<b>GREEN</b>	Mains voltage OK	Check mains voltage



Differentiated error and warning displays are only possible with the use of DCU 001 or HPU 001. Indication via PC is only possible with interface description "Pfeiffer protocol on RS 232/RS485", PM 0488 BN.

## 7.2. Temperature Monitoring Of The Turbopump

The operating performance is reduced at unacceptably high motor temperatures or unacceptably temperatures in the TM 3000. This can lead to a reduction in the set rotation speed switch point [P:701] and to the turbomolecular pump being switched off.

In this case, the red LED lights up (aggregated error message) on the Electronic Drive Unit And Magnetic Bearing Controller TM 3000.

## 8. What To Do In Case Of Breakdowns?

Problem	Mögliche Ursachen	Behebung
Pump does not start; None of the internal LEDs on the TM 3000 are lit;  green LED on the integrated power supply does not lit	<ul style="list-style-type: none"> <li>Power supply interrupted</li> <li>Incorrect operating voltage applied</li> <li>No operating voltage applied</li> <li>TM 3000 defective</li> <li>Power Supply power supply defectiv (please see Section 9.1.)</li> </ul>	<ul style="list-style-type: none"> <li>Check plug contact on the power supply</li> <li>Check the power supply line</li> <li>Check the voltage on the power supply (140 VDC) on the connection DC Out</li> <li>Apply appropriate operating voltage</li> <li>Check plug contacts on the power supply</li> <li>Notify Pfeiffer Vacuum Service for repairs</li> <li>Replacing Power Supply power supply</li> </ul>
Pump does not reach nominal rotation speed within the set start-up time; Pump switches off during operation in the TM 3000	<ul style="list-style-type: none"> <li>Fore vacuum pressure too high</li> <li>Leak or gas load too high</li> <li>Start-up time set too short in the TM 3000</li> <li>Thermal overload due to                             <ul style="list-style-type: none"> <li>Water flow rate too low</li> <li>Fore vacuum pressure too high</li> <li>Ambient temperature too high</li> </ul> </li> </ul>	<ul style="list-style-type: none"> <li>Check the backing pump function</li> <li>Check seals</li> <li>Look for leak and remove</li> <li>Process gas supply too high; reduce</li> <li>Set longer start-up time via DCU, HPU or PC</li> <li>Ensure free flow</li> <li>Reduce fore-vacuum pressure</li> <li>Reduce ambient temperature</li> </ul>
Pump does not reach final pressure	<ul style="list-style-type: none"> <li>Pump polluted</li> <li>Leak in vacuum chamber, lines or pump</li> </ul>	<ul style="list-style-type: none"> <li>If polluted: notify Pfeiffer Vacuum Service for cleaning</li> <li>Look for leak starting with vacuum chamber</li> <li>Repair leak</li> </ul>
Unusual noises during operation	<ul style="list-style-type: none"> <li>Rotor damaged                             <ul style="list-style-type: none"> <li>Foreign particles in the blade area</li> </ul> </li> <li>Centering ring with splinter shield not secure (if installed)</li> </ul>	<ul style="list-style-type: none"> <li>Notify Pfeiffer Vacuum Service for repair</li> <li>Check sit of centering ring with splinter shield</li> </ul>
Red LED lit up on TM 3000	<ul style="list-style-type: none"> <li>Aggregated error</li> </ul>	<ul style="list-style-type: none"> <li>Reset via mains on/off or Remote Pin 5</li> <li>Different error display with DCU 001 or HPU 001 possible <sup>1)</sup></li> </ul>
Red LED lit up on TM 3000	<ul style="list-style-type: none"> <li>Thermal overload</li> </ul>	<ul style="list-style-type: none"> <li>Reduce ambient temperature</li> <li>Check water cooling</li> </ul>

1) If no DCU 001 or HPU 001 is available, notify Pfeiffer Vacuum Service to check for cause of error.

## 9. Service

### Do make use of our service facilities

In the event that repairs are necessary a number of options are available to you to ensure any system down time is kept to a minimum:

- Have the pump repaired on the spot by our Pfeiffer Vacuum Service Engineers;
- Return the pump to the manufacturer for repairs;
- Replace the pump.

Local Pfeiffer Vacuum representatives can provide full details.



Please take into account that where Pfeiffer Vacuum Service replacement service is involved the standard operating parameters are always pre-set.

If your application requires different parameters, please modify accordingly.

You can obtain more detailed information from your Pfeiffer Vacuum representative.



The turbopump with the Magnetic Bearing Controller TM 3000 and power supply form a single unit and must therefore be returned complete for repair purposes.

### Before returning:

- ➔ Dismantle all accessories.
- ➔ If the unit is free of harmful substances, please attach a clearly visible notice "Free of harmful substances" (both on the unit and also on the delivery note and any accompanying letters).

"Harmful substances" are substances and preparations as defined in the current, local, dangerous substances regulations; in the U.S.A. as

"materials in accordance with the Code of Federal Regulations (CFR) 49 Part 173.240 Definition and Preparation". We will carry out the decontamination and invoice this work to you if you have not attached this note. This also applies where the operator does not have the facilities to carry out the decontamination work. Units which are contaminated microbiologically, explosively or radioactively cannot be accepted as a matter of principle.

### Fill out the declaration of contamination

- ➔ In every case the "Declaration of Contamination" must be completed diligently and truthfully.
- ➔ A copy of the completed declaration must accompany the unit; any additional copies must be sent to your local Pfeiffer Vacuum Service Center.

Please get in touch with your local Pfeiffer Vacuum representatives if there are any questions regarding contamination.



Decontaminate units before returning or possible disposal. Do not return any units which are microbiologically, explosively or radioactively contaminated.

### Returning contaminated units

If contaminated have to be returned for maintenance/repair, the following instructions concerning shipping must be followed:

- ➔ Neutralise the pump by flushing with nitrogen or dry air.
- ➔ Seal all openings to the air.
- ➔ Seal pump or unit in suitable protective foil.
- ➔ Return equipment only in suitable, rugged shipping containers and by complying with the currently valid shipping regulations.



Repair orders are carried out according to our general conditions of sale and supply.

If repairs are necessary, please send the pump to your nearest Pfeiffer Vacuum Service Center.

# 10. Maintenance / Replacement



We accept no liability for personal or material damages or interruptions to operation resulting from improper maintenance, and all liability and guarantee claims are rendered void.

You can change the integrated power supply yourself (see Section 10.1.).

Please contact your Pfeiffer Vacuum service location for all other maintenance or reconditioning.



Do not exert any mechanical load on the Electronic Drive Unit And Magnetic Bearing Controller TM 3000.

## 10.1. Replacing The Power Supply

Should the integrated power supply be defective, it may be replaced as described in the following.



Wait for the turbomolecular pump to arrive at a complete standstill (speed 0 Hz).

- ➔ Disconnect the power supply from the mains and wait at least one minute before removing plug 51 from the power supply.
- ➔ Shut off the water supply.
- ➔ If required remove the turbopump from the system.



Do not damage the sealing surface at the high vacuum flange.

- ➔ Unscrew the plug 51 from the power supply.
- ➔ Unscrew the cylinder head screws with hexagon socket 105a (4 pieces) and eye bolts A (2 pieces) or 6 cylinder head screws with hexagon socket 105a from the power supply (105), note washers.
- ➔ Detach the power supply (105) from the turbopump.

### Replacing the Integrated Power Supply

- A Eye bolt
- 1 High vacuum flange
- 8 Electronic Drive Unit And Magnetic Bearing Controller TM 3000
- 8a Connecting cable TM 3000-power supply
- 51 Plug (male)
- 53 Plug (female)
- 105 Power supply
- 105a Cylinder head screws with hexagon socket and shake proof washer

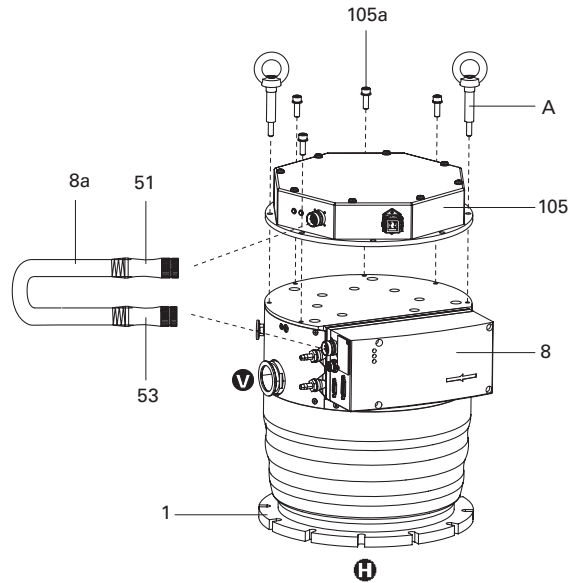

When installing the power supply, the bottom surfaces of power supply and turbomolecular pump must be clean and free of particles. In order to ensure heat dissipation during operation, the power supply must be bolted firmly on to the turbomolecular pump with 6 cylinder head screws with hexagon socket or 4 cylinder head screws with hexagon socket and 2 eye bolts.

- ➔ Bolt a new power supply to the turbomolecular pump (use new shake proof washers).
- ➔ Connect the connecting cable 8a again to the power supply and the magnetic bearing electronics.
- ➔ Provide the mains power connection again.

Now the turbomolecular pump is ready for operation.

### Ordering number

The power supply can be ordered by quoting the number PM C01 780.

# 11. Technical Data

Size	Unit	HiMag™ 2400		
Connection nominal diameter	Inlett	DN 250 ISO-K	DN 250 ISO-F	DN 250 CF-F
Venting/Sealing gas connection	Outlet		DN 40 ISO-KF DN 10 ISO-KF	
Nominal rotation speed	1/min / Hz		29 400 / 490	
Standby rotation speed	1/min / Hz		19 600 / 326	
rotation speed, fore-vacuum pressure ≤ 0.1 mbar	min		7	
Braking time with/without venting	min		1.5/10	
Connection pressure	bar		3 (absolute)	
venting valve/sealing gas valve	bar		3 (absolute)	
Max. sound pressure level <sup>1)</sup>	dB (A)		45	
Integral leak rate (He) <sup>2)</sup>	mbar l/s		$< 2 \cdot 10^{-8}$	
Max. permissible rotor temperature	°C		120	
Permissible heat radiation power	W		26	
Pumping speed for:				
Argon Ar	l/s		1900	
Nitrogen N <sub>2</sub>	l/s		2100	
Helium He	l/s		1950	
Hydrogen H <sub>2</sub>	l/s		1800	
Tetrafluoromethane CF <sub>4</sub>	l/s		1600	
Compression ratio for:				
Ar			$> 1 \cdot 10^9$	
N <sub>2</sub>			$> 1 \cdot 10^9$	
He			$3 \cdot 10^5$	
H <sub>2</sub>			$1 \cdot 10^4$	
CF <sub>4</sub>			$> 1 \cdot 10^9$	
Max. fore-vacuum pressure				
Ar	mbar		1.5	
N <sub>2</sub>	mbar		1.5	
He	mbar		2.0	
H <sub>2</sub>	mbar		0.5	
CF <sub>4</sub>	mbar		1.5	
Max. gas throughput		please refer to Section 4.11.		
Final pressure <sup>3)</sup>				
with OnTool	mbar		$< 1 \cdot 10^{-9}$	
with WOT 200	mbar		$< 1 \cdot 10^{-9}$	
Cooling water requirement <sup>4)</sup>	l/h		100	
Cooling water temperature	°C		15 - 35	
Weight	kg	77	81	81
Permissible magnetic field	mT		10	
Shipping and storage temperature	%		-25 °C to +55 °C	
Relative humidity of air	%		5-85 non condensing	
Power Supply:				
Operating voltage	VAC		208-240 ±10%	
Output voltage	V		140 ±3%	
Power input, max.	A		7	
Power, max.	W		900	
Protection category			I	
Protection class			IP 54	

1) Distance from the pump 1 m

2) Measured at a helium concentration of 20 %, 10 s measurement time

3) Final pressure is the pressure achieved in a measuring dome 48 hours after heating, in accordance with DIN 28 428.

4) At maximum gas throughput

## 11.1. Dimension Diagram

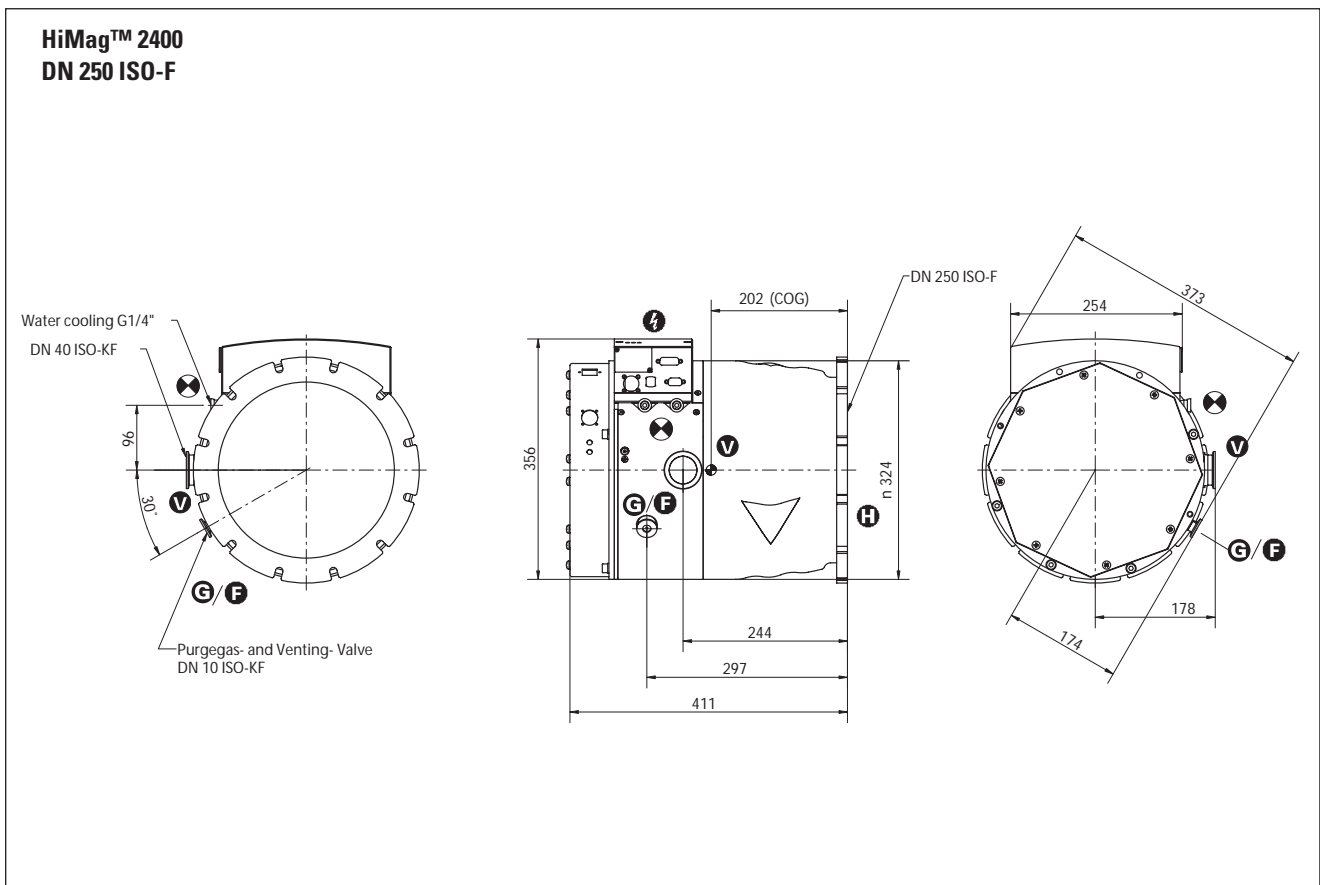
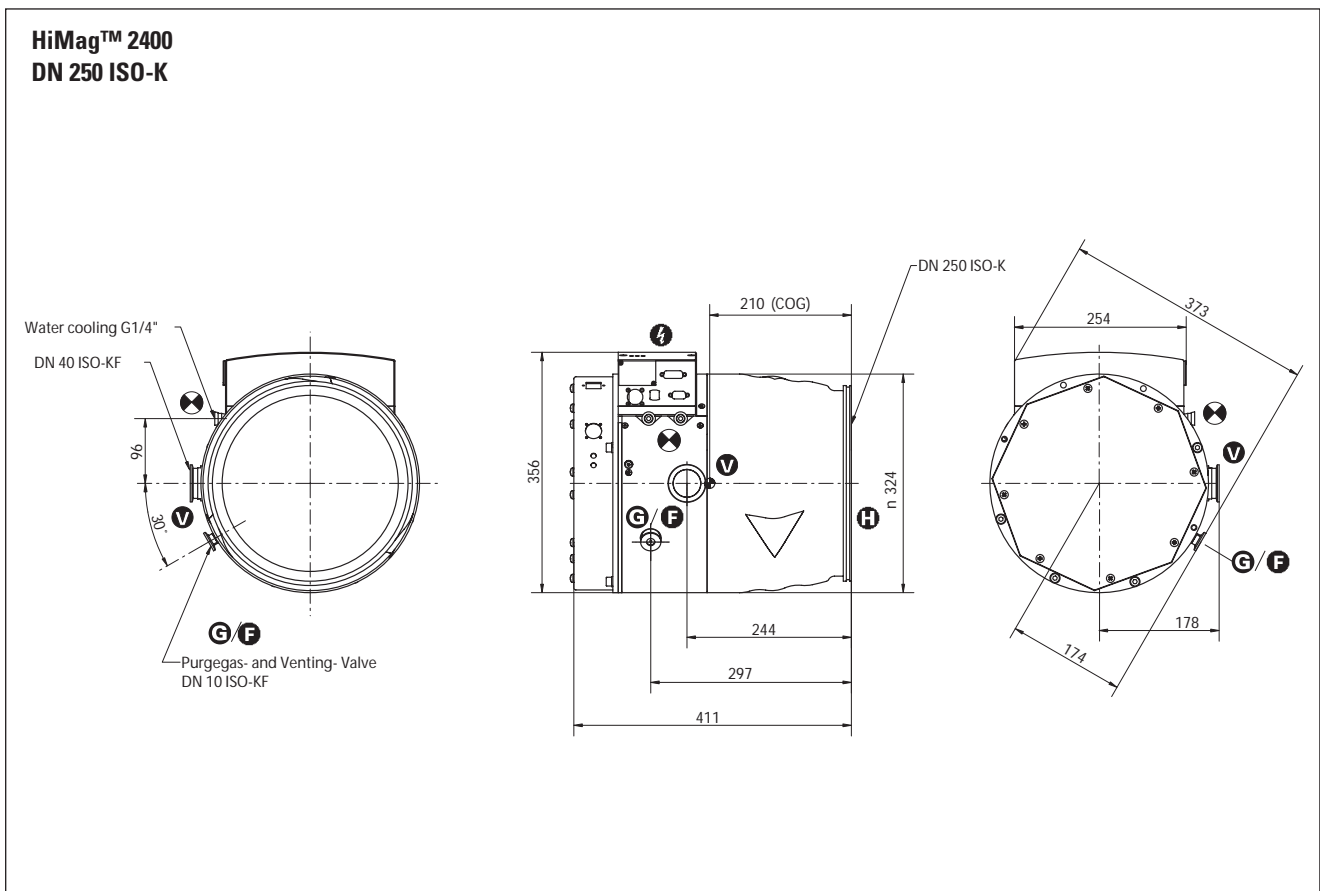

**HiMag™ 2400**  
**DN 250 CF-F**

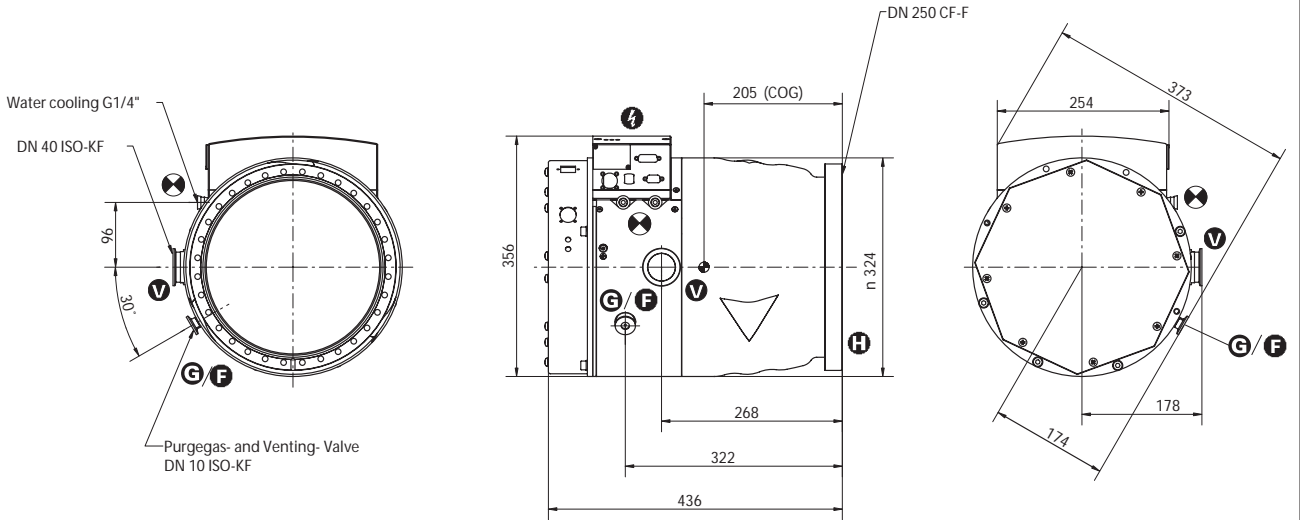

## 12. Accessories

Description	Size	Number	Note/ Additional Instructions	Order Amount
<b>Cooling components</b>				
Dirt trap Recycled Water Cooling TZK 2000	R 3/8" 230 V, 50 Hz	P 4161 300 2R PM Z01 240	PM 0369 BN	
<b>Venting components</b>				
Drier TTV 001 (filled with Zeolith)		PM Z00 121	PM 0022 BN	
<b>Components for mounting</b>				
Coated centering ring, bracket screws	DN 250 ISO-K	PM 016 420-T		
Coated centering ring with protect. screen, bracket screws	DN 250 ISO-K	PM 016 422-T		
Coated centering ring with splinter shield, bracket screws	DN 250 ISO-K	PM 016 421-T		
Coated centering ring, hexagonal bolts	DN 250 ISO-F	PM 016 480-T		
Coated centering ring with protect. screen, hexagonal bolts	DN 250 ISO-F	PM 016 482-T		
Coated centering ring with splinter shield, hexagonal bolts	DN 250 ISO-F	PM 016 481-T		
Coated centering ring, stud screws-	DN 250 ISO-F	PM 016 485-T		
Coated centering ring with protection screen, stud screws	DN 250 ISO-F	PM 016 487-T		
Coated centering ring with splinter shield, stud screws	DN 250 ISO-F	PM 016 486-T		
<b>Additional accessories</b>				
Mains cable Safety plug UL plug	230 V, 3 m 208 V, 3 m	P 4564 309 HA P 4564 309 HB		
Connecting cable DCU/HPU-TM 3000	3 m	PM 051 726 -T		
Display and Operating Unit DCU 001		PM 041 816 -T	PM 0477 BN	
Display and Operating Unit HPU 001		PM 051 510 -T	PT 0101 BN	
Relay box backing pump 1-phase 20 A Adapter cable for the relay box backing pump		PM 041 938 -T PM 061 144 -X	PT 0030 BN	
TIC 001, Level Converter RS 485 / 232		PM 051 054 -X	PM 0549 BN	
Fore-vacuum Safety Valve TVV 001	115 V 230 V	PM Z01 206 PM Z01 205	PM 0263 BN	

When ordering accessories and spare parts please be sure to state the full part number. When ordering spare parts please state additionally the unit type and unit number (see type plate). Please use this list as an order form (by taking a copy).

## Declaration of Contamination of Vacuum Equipment and Components

The repair and/or service of vacuum components will only be carried out if a correctly completed declaration has been submitted. Non-completion will result in delay.

The manufacturer could refuse to accept any equipment without a declaration.

**This declaration can only be completed and signed by authorised and qualified staff:**

**1. Description of component:**

- Equipment type/model: \_\_\_\_\_
- Code No.: \_\_\_\_\_
- Serial No.: \_\_\_\_\_
- Invoice No.: \_\_\_\_\_
- Delivery Date: \_\_\_\_\_

**2. Reason for return:**

\_\_\_\_\_

\_\_\_\_\_

\_\_\_\_\_

\_\_\_\_\_

**3. Equipment condition**

- Has the equipment been used?  
yes  no
- What type of pump oil was used?  
\_\_\_\_\_
- Is the equipment free from potentially harmful substances?  
yes  (go to section 5)  
no  (go to section 4)

**4. Process related contamination**

of equipment

- toxic yes  no
- corrosive yes  no
- microbiological hazard\*) yes  no
- explosive\*) yes  no
- radioactive\*) yes  no
- other harmful substances yes  no

\*) We will not accept delivery of any equipment that has been radioactively or microbiologically contaminated without written evidence of decontamination!

Please list all substances, gases and by-products which may have come into contact with the equipment:

Tradename Product name Manufacturer	Chemical name (or Symbol)	Danger class	Precautions associated with substance	Action if spillage or human contact
1.				
2.				
3.				
4.				
5.				

### 5. Legally Binding Declaration

I hereby declare that the information supplied on this form is complete and accurate. The despatch of equipment will be in accordance with the appropriate regulations covering Packaging, Transportation and Labelling of Dangerous Substances.

Name of Organisation: \_\_\_\_\_

Address: \_\_\_\_\_ Post code: \_\_\_\_\_

Tel.: \_\_\_\_\_

Fax: \_\_\_\_\_ Telex: \_\_\_\_\_

Name: \_\_\_\_\_

Job title: \_\_\_\_\_

Date: \_\_\_\_\_ Company stamp: \_\_\_\_\_

Legally binding signature: \_\_\_\_\_



## **Herstellererklärung Manufacturer's Declaration**

im Sinne folgender EU-Richtlinien:  
*pursuant to the following EU directives:*

- **Maschinen/Machinery 98/37/EWG (Anhang/Annex II B)**
- **Elektromagnetische Verträglichkeit/Electromagnetic Compatibility 89/336/EWG**
- **Niederspannung/Low Voltage 73/23/EWG**

Hiermit erklären wir, dass das unten aufgeführte Produkt zum Einbau in eine Maschine bestimmt ist und dass deren Inbetriebnahme so lange untersagt ist, bis festgestellt wurde, dass das Endprodukt den Bestimmungen der EU-Richtlinie 98/37/EWG entspricht.

Das unten aufgeführte Produkt entspricht den Anforderungen der EU-Richtlinien **Maschinen 98/37EWG, Elektromagnetische Verträglichkeit 89/336/EWG** und **Niederspannung 73/23/EWG**.

*We hereby certify that the product specified below is intended for installation in a machine which is forbidden to be put into operation until such time as it has been determined that the end product is in accordance with the provision of EU Directive 98/37/EEC.*

*The product specified below is in correspondence to the EU directives **Machinery 98/37/EEC, Electromagnetic Compatibility 89/336/EEC** and **EU Low Voltage 73/23/EEC**.*

**Produkt/Product:**

**HiMag® 2400 / HiMag™ 2400**

Angewendete Richtlinien, harmonisierte Normen und angewendete nationale Normen:

*Guidelines, harmonised standards, national standards in which have been applied:*

EN 12100-1  
EN 12100-2

EN 294  
EN 61 010

EN 1012-2

Unterschrift/Signature:



Pfeiffer Vacuum GmbH  
Berliner Str. 43  
35614 Asslar  
Germany

(W. Dondorf)  
Geschäftsführer  
Managing Director

Herst.l/2003



**Vacuum is nothing, but everything to us!**



**Turbopumps**



**Rotary vane pumps**



**Roots pumps**



**Dry compressing pumps**



**Leak detectors**



**Valves**



**Components and feedthroughs**



**Vacuum measurement**



**Gas analysis**



**System engineering**



**Service**

**PFEIFFER**  **VACUUM**

Pfeiffer Vacuum Technology AG · Headquarters/Germany

Tel. +49-(0) 64 41-8 02-0 · Fax +49-(0) 64 41-8 02-2 02 · info@pfeiffer-vacuum.de · www.pfeiffer-vacuum.net