

# Instruction Manual



For sales and service please call:

PTB Sales

Ph. (626) 334-0500

Fax (626) 334-2151

Toll Free 866-332-0500

[www.ptb-sales.com](http://www.ptb-sales.com)

## *EXC100E and EXC100L Turbomolecular Pump Controllers*

### *Description*

*EXC100E Turbomolecular Pump Controller*

*EXC100L Turbomolecular Pump Controller*

### *Item Number*

*D396-20-000*

*D396-22-000*



### **Edwards High Vacuum International**

Manor Royal, Crawley, West Sussex, RH10 2LW, UK

Telephone: +44 (0) 1293 528844 Fax: +44 (0) 1293 533453

<http://www.bocedwards.com>



# Declaration of Conformity

We, BOC Edwards,  
Manor Royal,  
Crawley,  
West Sussex RH10 2LW, UK

declare under our sole responsibility that the product(s)

Turbomolecular Pump Controllers

EXC100L

D396-22-000

EXC100E

D396-20-000

to which this declaration relates is in conformity with the following standard(s)  
or other normative document(s)

IEC1010-1 (1992)

Safety Requirements for Electrical Equipment for Measurement,  
Control and Laboratory Use.

EN61326  
(Class B Emissions)

Electrical Equipment for Measurement, Control and Laboratory Use  
- EMC Requirements.

following the provisions of

73 / 023 / EEC

Low Voltage Directive.

89 / 336 / EEC

Electromagnetic Compatibility Directive.

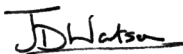

Dr. J.D. Watson, Senior Technical Manager, VED

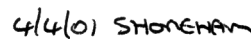

Date and Place

This product has been manufactured under a quality system registered to ISO9001

 **BOC EDWARDS**

# CONTENTS

Section	Title	Page
1	INTRODUCTION	1
1.1	Scope and definitions	1
1.2	Description	2
1.3	Connection of an Active gauge	3
1.4	Logic interface	3
1.4.1	Introduction	3
1.4.2	Electrical supplies	4
1.4.3	Control inputs	4
1.4.4	Status outputs	4
1.4.5	Analogue outputs	5
1.5	Vent-valve control	5
1.5.1	Introduction	5
1.5.2	Vent on Stop	6
1.6	Controller Fail conditions	6
1.6.1	General	6
1.6.2	Internal Timer	7
2	TECHNICAL DATA	9
2.1	Operating and storage data	9
2.2	Mechanical data	9
2.3	Electrical supply	9
2.4	EXT pump electrical output data	9
2.5	Logic interface	10
2.6	Factory settings	10
2.7	Electrical connectors	10
3	INSTALLATION	12
3.1	Unpack and inspect	12
3.2	Configure the Controller	12
3.2.1	Introduction	12
3.2.2	Select speed or power analogue output	12
3.2.3	Enable/disable the Internal Timer to monitor low pump speed	14
3.2.4	Vent options	14
3.3	Fit the Controller	15
3.4	Introduction to Controller electrical connections	15
3.5	Connect the electrical supply	18
3.6	Connect additional earth (ground) bonding (if required)	18
3.7	Connect the EXT pump	19
3.8	Connect an AIM Active Inverted Magnetron gauge (optional)	19
3.9	Connect the logic interface to your equipment	19
3.9.1	Introduction	19
3.9.2	Connect a vacuum gauge to the logic interface	20
3.10	Adjust the Normal speed	20
3.11	Adjust the Internal Timer	20

Section	Title	Page
4	OPERATION	22
4.1	Start-up	22
4.2	Standby	22
4.3	Operation with high inlet pressure	22
4.4	Operation with high pump temperature	23
4.5	Normal shutdown	23
4.6	Automatic shutdown after Fail condition	23
4.7	Reset the Controller after Fail condition	23
4.10	Electrical supply failure	24
5	MAINTENANCE	25
5.1	Safety	25
5.2	Replace a fuse	25
5.2.1	Introduction	25
5.2.2	Replace the electrical supply fuse	25
5.3	Clean the Controller	25
5.4	Fault finding	25
6	STORAGE AND DISPOSAL	26
6.1	Storage	26
6.2	Disposal	26
7	SERVICE, SPARES AND ACCESSORIES	27
7.1	Introduction	27
7.2	Service	27
7.3	Accessories	27
7.3.1	Electrical supply cable	27
7.3.2	Pump-to-controller cable	28
7.3.3	BX bakeout band	28
7.3.4	TAV vent-valve	28
7.3.5	ACX air-cooler	29
7.3.6	Active vacuum gauges	29
8	ENGINEERING DIAGRAMS	29
	RETURN OF BOC EDWARDS EQUIPMENT	

## Illustrations

Figure	Title	Page
1	Rear panel of the Controller (EXC100E shown)	8
2	Dimensions (mm): EXC100E shown	11
3	Reconfigure the Controller (EXC100L shown)	13
4	Schematic diagram of Controller electrical connections	17
5	Normal Speed and Internal Timer potentiometers (EXC100L shown)	21
6	EXC Controller to EXT pump connections	30
7	Active Gauge connector	31

## Tables

Table	Title	Page
1	Configuration links	12
2	Selection of vent-valve control options	14
3	Logic interface pins	16
4	Electrical supply cable wires	18
5	APG to logic interface connections	20
6	Active Gauge connector pins	31

## Associated Publications

Publication title	Publication Number
EXT Pump Accessories	B580-66-880
EXT70 and EXT250 Turbomolecular pumps	B722-01-880
EXT351 and EXT501 Turbomolecular Pumps	B727-20-880



# 1 INTRODUCTION

## 1.1 Scope and definitions

This manual provides installation, operation and maintenance instructions for the BOC Edwards EXC100E and EXC100L Turbomolecular Pump Controllers. You must use the Controller as specified in this manual.

Read this manual before you install and operate the Controller. Important safety information is highlighted as WARNING and CAUTION instructions; you must obey these instructions. The use of WARNINGS and CAUTIONS is defined below.

### WARNING

Warnings are given where failure to observe the instruction could result in injury or death to people.

### CAUTION

Cautions are given where failure to observe the instruction could result in damage to the equipment, associated equipment or process.

The units used throughout this manual conform to the SI international system of units of measurement.

In accordance with the recommendations of IEC1010, the following warning symbols appear on the Controller.



Caution - refer to accompanying documents



Caution - risk of electric shock



Protective conductor terminal



Direct current only

## 1.2 Description

The EXC Controller generates the electrical supply and the control signals necessary to operate an EXT pump and its accessories. Refer to Section 2 for compatible EXT pumps.

The Controller has a high-efficiency, auto-ranging power supply which adjusts itself to any external electrical supply in the specified voltage range (refer to Section 2). The power supply converts the single-phase electrical supply into a regulated d.c. electrical supply to control the operation of the EXT pump. The pump has three Hall effect devices which operate as rotor position sensors. These sensors ensure that the drive current is correctly switched to the phase-windings of the pump-motor. The Hall effect devices also generate a speed signal which the Controller uses to regulate the rotational speed of the pump.

The Controller has a secondary regenerative supply which uses the d.c. motor of the EXT pump as a generator. If the electrical supply fails, the regenerative supply provides the Controller with a back-up source of power without the need for batteries. The Controller uses the regenerative supply to maintain the electrical supplies to the vent-valve, air-cooler and AIM gauge (if connected) until the pump speed falls to below 50% of full rotational speed (see Section 1.5.2).

The Controllers have a number of control features which limit the power supplied to the EXT pump in the event of sustained high pressure or temperature:

- If the EXT pump inlet pressure rises, the power supplied to the pump-motor increases to counteract the gas frictional load. The pump rotational speed remains constant until the Controller peak power level is reached; beyond this power level, the speed of the pump starts to reduce. If the pump speed falls to below 50% of its full rotational speed, the Controller may trip into Fail condition; this depends on how you have configured the Controller (see Section 1.6.2).
- If the Controller detects that its temperature or the pump temperature is too high, it reduces the power supplied to the pump-motor; the pump may not therefore be able to maintain full rotational speed if it is too hot. If the pump speed falls to below 50% of its full rotational speed, the Controller may trip into Fail condition; this depends on how you have configured the Controller (see Section 1.6.2).

The Controller has no front-panel controls and can only be operated through the logic interface. To operate the EXT pump, you must therefore connect the Controller to your own control equipment. Alternatively, you can configure the mating-plug for the logic interface connector so that the EXT pump starts to operate as soon as the electrical supply to the Controller is switched on: refer to Section 3.9.

The rear-panel of the Controller has a Normal LED (Figure 1, item 6). The LED is on whenever the TMP Normal status output signal is low: refer to Section 1.4.4.

The EXC100L Controller has an integral pump-to-controller cable. The EXC100E Controller has a mating connector suitable for a pump-to-controller cable accessory (not supplied): refer to Section 7.

## 1.3 Connection of an Active gauge

*Note: The Controller contains a regenerative power supply which maintains the electrical supply to the AIM gauge in the event of a failure of the external electrical supply to the Controller (see Section 1.2).*

You can connect an BOC Edwards AIM Active Inverted Magnetron Gauge directly to the active gauge connector on the Controller and use the Controller TMP Normal signal to switch the gauge on. This allows you to control the AIM Gauge without the need to use an additional high pressure gauge (and its associated control equipment) to interlock the operation of the AIM Gauge to system pressure. Refer to Section 3.8 for details about how to connect an AIM gauge to the Controller.

If you want to use another type of gauge, you must connect the gauge to the Controller through the logic interface: refer to Section 3.9.

## 1.4 Logic interface

### 1.4.1 Introduction

The rear panel of the Controller has a 15-way logic interface connector (Figure 1, item 4) which you can use to connect the Controller to your own equipment.

Signals on the logic interface are of four types:

- **Electrical supplies**      These are electrical supplies for optional accessories connected to your pump, such as the vent-valve and the air-cooler.
- **Control inputs**      These are switch-type input signals which are used to control the operation of the EXT pump.
- **Status outputs**      These output signals identify the status of the pump and the Controller.
- **Analogue output**      The Controller can be configured to provide a speed output or a power output. This output gives an indication of the EXT pump speed or power consumption.

Refer to Table 3 and to Figure 4 for detailed information about the logic interface pins and their uses. A general description of the logic interface connections follows.

## 1.4.2 Electrical supplies

Two nominal 24 V supplies are provided, as described below:

### Vent-valve supply

This electrical supply is provided to operate a vent-valve fitted to your EXT pump or vacuum system. The Controller automatically opens the valve when the speed of the pump falls to below 50% of full rotational speed. You can also configure the Controller to operate the valve in other specific conditions: refer to Sections 1.5 and 3.2.

### Air-cooler supply

This electrical supply is provided to operate an ACX air-cooler fitted to your EXT pump. The electrical supply is on whenever the Controller is on. Alternatively, if your pump is water-cooled, you can use this supply to operate a solenoid-valve to control the flow of water through the water-cooler.

## 1.4.3 Control inputs

You can use these inputs to control the operation of the EXT pump. The input signals are switch-type signals; you link (close) two pins on the logic interface when you want to set the required signal and you do not link (open) the pins when you do not want to set the signal. The input signals are as follows:

### Start/Stop

Use the Start/Stop input to Start and Stop the EXT pump. To Start the pump, you must close the Start/Stop input. To Stop the pump, you must open the input (refer to Sections 4.1 and 4.5).

### Standby

Close the Standby input to select pump Standby (refer to Section 4.2).

## 1.4.4 Status outputs

The Controller provides Normal, Fail and Pump On status output signals (TMP Normal, TMP Fail and TMP On) through open collector transistor outputs on the logic interface connector. These signals can be used to control devices in the pumping system or to provide remote status output signals. The signals operate as described below.

### TMP Normal

TMP Normal is normally high and goes low when the EXT pump reaches its 'Normal' speed. The Normal speed is determined by a potentiometer on the side of the Controller. The Controller is supplied with the potentiometer adjusted so that Normal speed is 80% of full rotational speed. You can adjust the Normal speed as described in Section 3.10. The Normal LED on the rear panel of the Controller (Figure 1, item 6) is on when the TMP Normal signal is low.

## **TMP Fail**

TMP Fail is normally low and goes high when the Controller trips into a Fail condition (see Section 1.6).

## **TMP On**

The TMP On signal mimics the operation of the vent-valve. If you select Vent On Stop (see Section 1.5.2), TMP On is normally high and goes low when the electrical supply to the EXT pump is switched on by the Controller.

### **1.4.5 Analogue output**

The Controller has a single analogue output signal, which can be configured to indicate either Pump Speed or Pump Power consumption.

The Controller is supplied configured so that the analogue output signal is proportional to EXT pump speed. Connect the output to a suitable meter or indicator to display the pump speed or connect the output to your control equipment (for example, to operate other components in the pumping system at a preset EXT pump speed).

If required, you can configure the Controller so that the analogue output signal is proportional to the electrical power drawn by the EXT pump (see Sections 2.5 and 3.2.2). Connect the output to a suitable meter or indicator to display the pump power or connect the output to your control equipment.

## **1.5 Vent-valve control**

### **1.5.1 Introduction**

*Note: The factory settings for vent options are shown in Table 2.*

If the Controller electrical supply fails, the Controller maintains the electrical supply to the vent-valve until the pump speed falls to below 50% of full rotational speed, then the Controller switches off the vent-valve electrical supply. This feature of the Controller cannot be reconfigured.

However, you can use the configuration links in the Controller (refer to Section 3.2.4) to select a combination of vent options in response to the Stop input signal and the TMP Fail output signal.

When a selected vent option condition is detected, the Controller:

- waits approximately two seconds, to allow a vacuum system isolation-valve (if fitted) to close,
- then switches off the electrical supply to the vent-valve.

## 1.5.2 Vent on Stop

If Vent on Stop is selected when you switch the Controller on, the vent-valve electrical supply remains off until Start is selected. When Start is selected, the Controller switches the vent-valve electrical supply on. If Stop is then selected, the Controller switches the vent-valve electrical supply off again.

If Vent on Stop is not selected when you switch the Controller on, the vent-valve electrical supply remains off until Start is selected. When Start is selected, the Controller switches the vent-valve electrical supply on. If Stop is then selected, the EXT pump will decelerate and the vent-valve electrical supply will remain on until the pump speed falls to below 50% of full rotational speed; the vent-valve electrical supply will then be switched off.

## 1.5.3 Vent on Fail

If Vent on Fail is selected, then the setting of the Vent on Stop option determines how the vent-valve is controlled in response to a Fail condition, as follows:

- If you have selected Vent on Stop and a failure occurs, the Controller switches the vent-valve electrical supply off approximately two seconds after the the Fail condition is detected.
- If you have not selected Vent on Stop, the EXT pump will decelerate and the vent-valve electrical supply will remain on until the pump speed falls to below 50% of full rotational speed; the vent-valve electrical supply will then be switched off.

If you have not selected Vent on Fail, the electrical supply to the vent-valve will not be switched off when a Fail condition is detected.

## 1.6 Controller Fail conditions

### 1.6.1 General

*Note: If you enable the Internal Timer (see Sections 1.6.2 and 3.2.3), the Controller will trip into Fail condition only after the preset time has elapsed.*

The Controller will trip into Fail condition if either of the following occurs:

- The EXT pump does not reach 50% of full rotational speed within a preset time after it starts (the time set by the adjustable Internal Timer: see Sections 1.6.2 and 3.2.3).
- The EXT pump speed falls to below 50% of its full rotational speed.

When the Controller trips into Fail condition, the electrical supply to the EXT pump-motor is switched off and the TMP Fail status output signal on the logic interface goes high. The operation of the vent-valve depends on how you have configured the Controller (refer to Sections 1.5 and 3.2). To reset the Controller after a Fail condition has occurred, refer to Section 4.7.

## 1.6.2 Internal Timer

The Internal Timer has two functions:

Firstly, when the EXT pump is started by the Controller, the Internal Timer in the Controller also starts. If the EXT pump does not reach 50% of full rotational speed within the preset time measured by the timer, the Controller will trip into Fail condition. This function cannot be disabled.

Secondly, you can configure the Controller to enable or disable the Internal Timer if the pump speed falls during pump operation:

- If you disable the Internal Timer, the Controller will trip into Fail condition as soon as the pump speed falls to below 50% of full rotational speed.
- If you enable the Internal Timer, the Internal Timer will start as soon as the pump speed falls to below 50% of full rotational speed; the Controller will trip into Fail condition if the pump speed is still below 50% of full rotational speed at the end of the preset time.

The Controller is supplied with the Internal Timer enabled and adjusted for a preset time of eight minutes. You can adjust the timer for your application: refer to Section 3.11.

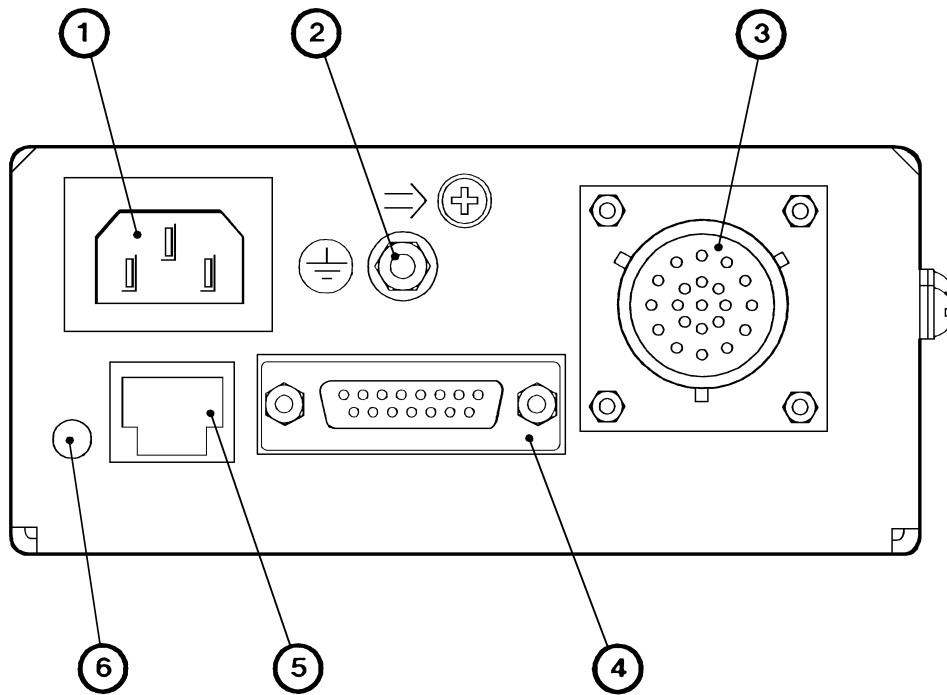

AW/1812/A

- |                                |                              |
|--------------------------------|------------------------------|
| 1. Electrical supply connector | 4. Logic interface connector |
| 2. Earth (ground) stud         | 5. Active gauge connector    |
| 3. EXT pump connector *        | 6. Normal LED                |

\* EXC100E only; the EXC100L has an integral pump-to-controller cable

Figure 1 - Rear panel of the Controller (EXC100E shown)

## 2 TECHNICAL DATA

### 2.1 Operating and storage data

Ambient operating temperature range	0 to 40 °C
Ambient storage temperature range	-20 to 70 °C
Maximum ambient operating humidity	10 to 95% RH (non-condensing to DIN 40040)
Maximum operating altitude	3000 m
Cooling	Natural convection

### 2.2 Mechanical data

Dimensions	See Figure 2
Mass	
EXC100E	0.8 kg
EXC100L	1.0 kg
Enclosure protection	IP20 (as defined by IEC529)
Pollution degree	IEC664, category 2

### 2.3 Electrical data

Electrical supply	
Voltage	90 to 264 V a.c., single-phase
Frequency	47 to 63 Hz
Maximum input power	220 VA
Peak inrush current	11 A at 110 V a.c. 40 A at 240 V a.c.
Fuse rating	2 A, type T 20 mm
Over-voltage transients	IEC664, category 2
Radiated electromagnetic emission	EN50081-1
Electromagnetic immunity	EN50082-2

### 2.4 EXT pump electrical output data

Compatible EXT pumps	EXT70, EXT250, EXT351
Maximum continuous output power	80 W
Maximum output voltage	53 V a.c. r.m.s.
Switching frequency	32 kHz
Nominal output frequency	600 Hz to 1.5 kHz
Maximum output frequency	1.07 x nominal
Standby frequency	70% of nominal

## 2.5 Logic interface

Remote control signals	
Control voltage: low (close)	< 0.8 V d.c.
Control voltage: high (open)	4 to 24 V d.c.
Maximum input current (at 24 V)	80 $\mu$ A
Maximum output current (at 0 V d.c.)	160 $\mu$ A
Air-cooler electrical supply	
Voltage range	+20 to +26 V d.c.
Maximum output current	150 mA
Vent-valve electrical supply	
Voltage range	+16 to +26 V d.c.
Maximum output current	80 mA
Analogue output	
Output voltage	0 to +10 V d.c. proportional to speed or power: 0 to 10 V $\cong$ 0 to 100% of pump speed, or 0 to 10 V $\cong$ 0 to 80 W motor power
Maximum output current	5 mA
TMP Normal and TMP Fail status outputs	
Maximum output voltage (high)	26 V d.c.
Maximum output current	
Vout (low) $\geq$ 0.8 V	20 mA
Vout (low) <0.8 V (TTL level)	1 mA
TMP On status output	
Logic high output voltage at 8 $\mu$ A	4.12 V
Logic low output voltage at 42 $\mu$ A	0.77 V

## 2.6 Factory settings

Normal speed	80%
Internal Timer	8 min, enabled
Vent options	See Table 2
Analogue output	Speed output

## 2.7 Electrical connectors

*Note: Do not connect voltages greater than 45 V to the logic interface. If you do, the Controller will not comply with the low voltage safety recommendations of IEC 1010.*

Electrical supply connector socket type	CEE/IEC 320
Earth (ground) stud (on rear panel)	M4
Active gauge connector	
Signals on the connector pins	See Figure 6 and Table 4
Socket type	FCC68, 8-way
Manufacturer	Western Electric
Maximum power	3 W
Logic interface connector	15-way sub-miniature 'D' type socket

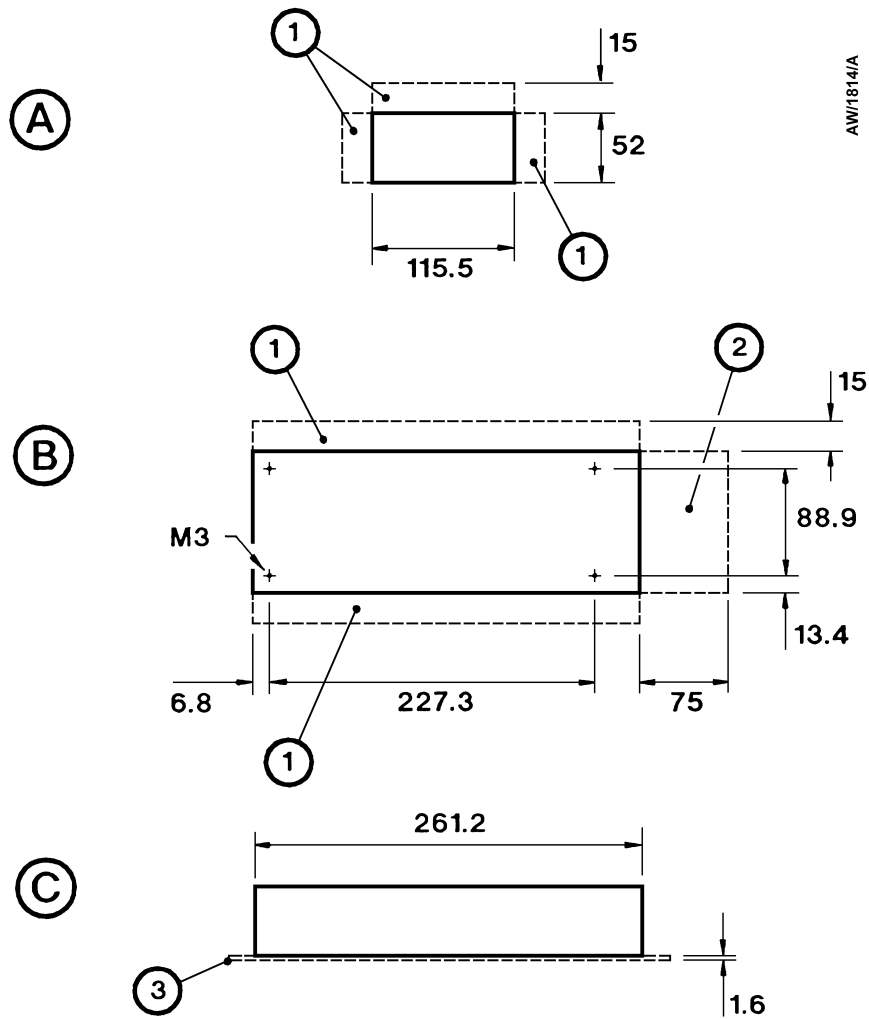

- |   |           |    |                           |
|---|-----------|----|---------------------------|
| A | Rear view | 1. | Clearance for ventilation |
| B | Top view  | 2. | Clearance for cables      |
| C | Side view | 3. | Optional mounting plate   |

Figure 2 - Dimensions (mm): EXC100E shown

## 3 INSTALLATION

### 3.1 Unpack and inspect

Remove all packing materials and check the Controller. If the Controller is damaged, notify your supplier and the carrier in writing within three days; state the Item Number of the Controller together with your order number and your supplier's invoice number. Retain all packing materials for inspection. Do not use the Controller if it is damaged.

If the Controller is not to be used immediately, store the Controller in suitable conditions, as described in Section 6.

### 3.2 Configure the Controller

#### 3.2.1 Introduction

The Controller has four links which can be used to configure the Controller for your application: see Table 1. Each link can be in one of two positions as shown in Figure 3 and described in Sections 3.2.2 and 3.2.4.

If you want to reconfigure the Controller, undo and remove the two screws (Figure 3, items 1) and remove the top cover (2) of the Controller to access the links. Use the links as described in the following sections.

Link	Use
LK1	Select speed or power analogue output
LK4	Enable or disable the Internal Timer
LK5	Select Vent on Stop or no Vent on Stop
LK6	Select Vent on Fail or no Vent on Fail

Table 1 - Configuration links

#### 3.2.2 Select speed or power analogue output

*Note: The Controller is supplied with link LK1 configured to provide the pump speed analogue output signal on the logic interface.*

Refer to Figure 3. To select the pump speed analogue output signal on the logic interface, insert link LK1 in the upper position (5).

To select the pump power analogue output signal on the logic interface, insert link LK1 in the lower position (6).

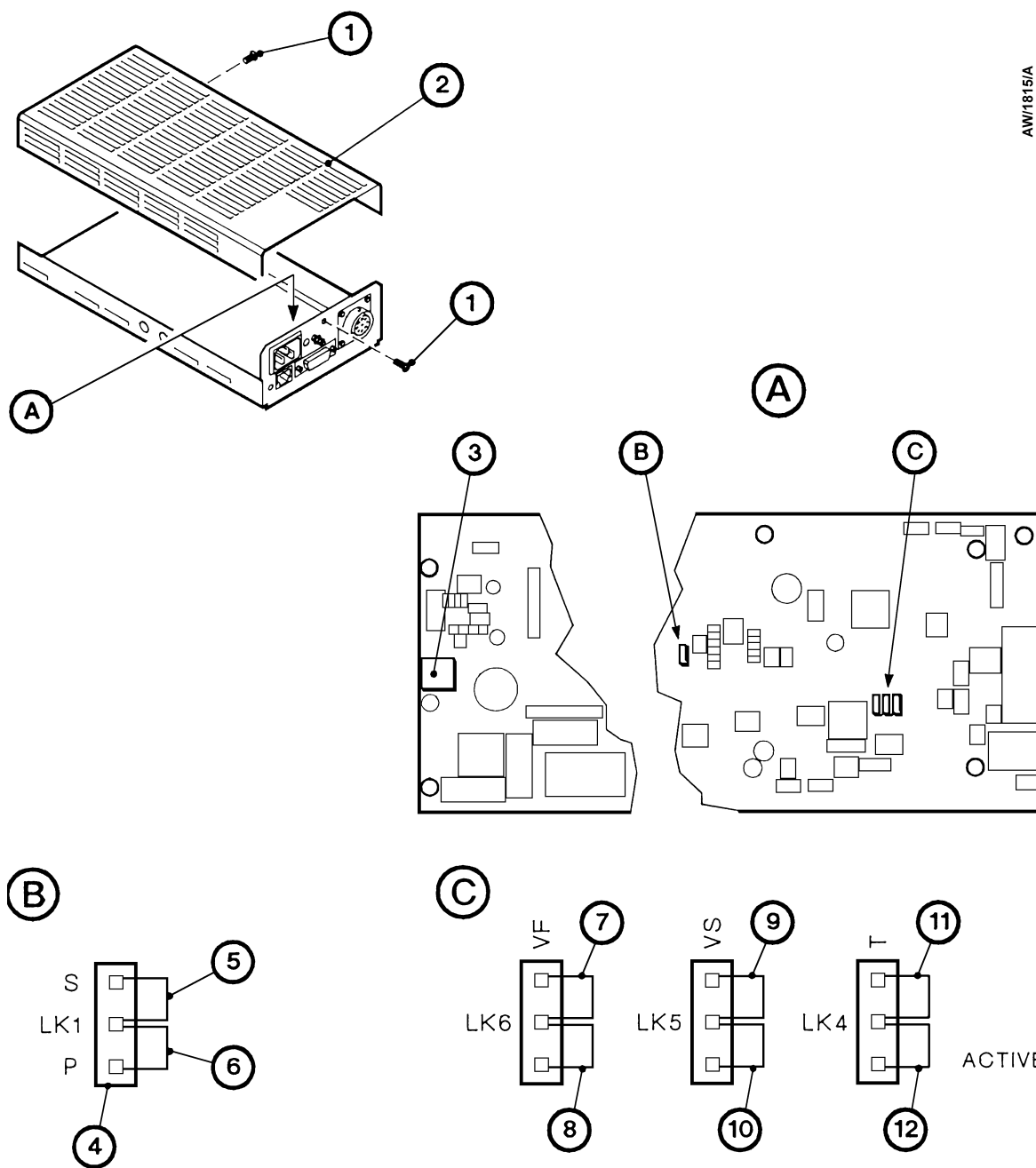

- |  |  |
|--|--|
| <ul style="list-style-type: none"> <li>1. Screw</li> <li>2. Top cover</li> <li>3. Fuse holder</li> <li>4. Speed/power link: LK1</li> <li>5. Link LK1 in speed configuration</li> <li>6. Link LK1 in power configuration</li> </ul> | <ul style="list-style-type: none"> <li>7. Link LK6 not active: Vent On Fail not selected</li> <li>8. Link LK6 active: Vent On Fail selected</li> <li>9. Link LK5 not active: Vent On Stop not selected</li> <li>10. Link LK5 active: Vent On Stop selected</li> <li>11. Link LK4 not active: Timer disabled</li> <li>12. Link LK4 active: Timer enabled</li> </ul> |
|--|--|

Figure 3 - Reconfigure the Controller (EXC100L shown)

### 3.2.3 Enable/disable the Internal Timer to monitor low pump speed

*Notes: If you pump a high gas load when the Internal Timer is enabled (link LK4 in the enabled position: Figure 3, item 12), the EXT pump may stall before the Controller trips into Fail condition. Ensure that oil which backstreams from the backing pipeline will not adversely affect your process. Disable the Internal Timer to provide the greatest protection against backstreaming if a Fail condition occurs.*

*The Controller is supplied with the Internal Timer enabled.*

Set link LK4 to enable or disable the use of the Internal Timer when the pump rotational speed falls to below 50% of full rotational speed during operation (see Section 1.6.2):

- **Insert link LK4 in the active position (Figure 3, item 12) to enable the Timer.** The Internal Timer will then start as soon as the pump rotational speed falls to below 50% of full rotational speed. If the pump speed remains below 50% of full rotational speed after the preset time, the Controller will trip into the Fail condition.
- **Insert link LK4 in the not active position (Figure 3, item 11) to disable the Timer.** The Controller will then trip into the Fail condition as soon as the pump rotational speed falls to below 50% of full rotational speed.

### 3.2.4 Vent options

Links LK5 and LK6 are used to select the vent-valve control options (refer to Section 1.5). Each of the links can be in one of two positions: the link not active position and the link active position. Position the links to select the required vent options as shown in Table 2.

Note however, that if the electrical supply to the Controller fails, the Controller will always switch off the electrical supply to the vent-valve when the EXT pump speed falls to below 50% of full speed (see Section 1.6.1).

Link positions		Vent options
LK6 (Vent on Fail)	LK5 (Vent on Stop)	
not active	not active	Vent when the EXT pump speed falls to 50% of full speed after Stop is selected or a Fail condition is detected.
not active	active	Vent on Stop; vent when the EXT pump speed falls to 50% of full speed after a Fail condition is detected.
active *	not active *	Vent on Fail; vent when the EXT pump speed falls to 50% of full speed after Stop is selected.
active	active	Vent on Fail and vent on Stop.

\* Link positions as supplied.

Table 2 - Selection of vent-valve control options

### 3.3 Fit the Controller

#### WARNING

The Controller contains electrolytic capacitors and, under certain fault conditions, may emit dangerous fumes. Ensure that the Controller is operated in a well-ventilated area.

#### CAUTION

You must allow the correct clearances for air circulation and you must fit the Controller onto a thermally conductive surface. If you do not, the performance and reliability of the Controller may be affected at high operating temperatures.

You must fit the Controller in a rack or cabinet. You can operate the Controller in a horizontal position or in a vertical position with the side vents at the top.



When you fit the Controller, you must allow 15 mm clearance at the sides of the Controller for air circulation and you must allow 75 mm clearance at the back of the Controller for the cables.

You must firmly fit the Controller onto a thermally conductive material, for example aluminium or steel. The location of the bottom panel fixing-holes are shown in Figure 2.

### 3.4 Introduction to Controller electrical connections

When you make the electrical connections to the Controller described in the following sections, refer to Table 3 for full details of the logic interface connections and refer to Figure 4 which shows a schematic diagram of the electrical connections.

You must provide suitable strain-relief on the cables which you fit to the Controller.

Pin number	Signal	Polarity*	Signal type
1	TMP On (low when pump is on)	N/A	Status outputs
7	TMP Fail (high when fail condition exists)	N/A	
8	Status output common	N/A	
15	TMP Normal (low when pump is at Normal speed) †	N/A	
3 4	 Start/Stop: Close for Start	+ -	Control input
11 4	 Standby: Close for Standby	+ -	Control input
10	RFI screen	N/A	N/A
5	Vent-valve electrical supply: 24 V	+	Supply
13	Vent-valve control ◆	-	
6	Air-cooler electrical supply: 24 V	+	Supply
14	Air-cooler electrical supply: 0 V	-	
9 2	 Pump speed or power	+ -	Analogue output

\* + = positive, - = negative, N/A = not applicable.

† This output is only TTL compatible when the current drawn is < 1 mA. Refer to Section 2 for more information.

◆ This supply line is raised to +24 V to de-energise the valve coil and vent the system.

Table 3 - Logic interface pins

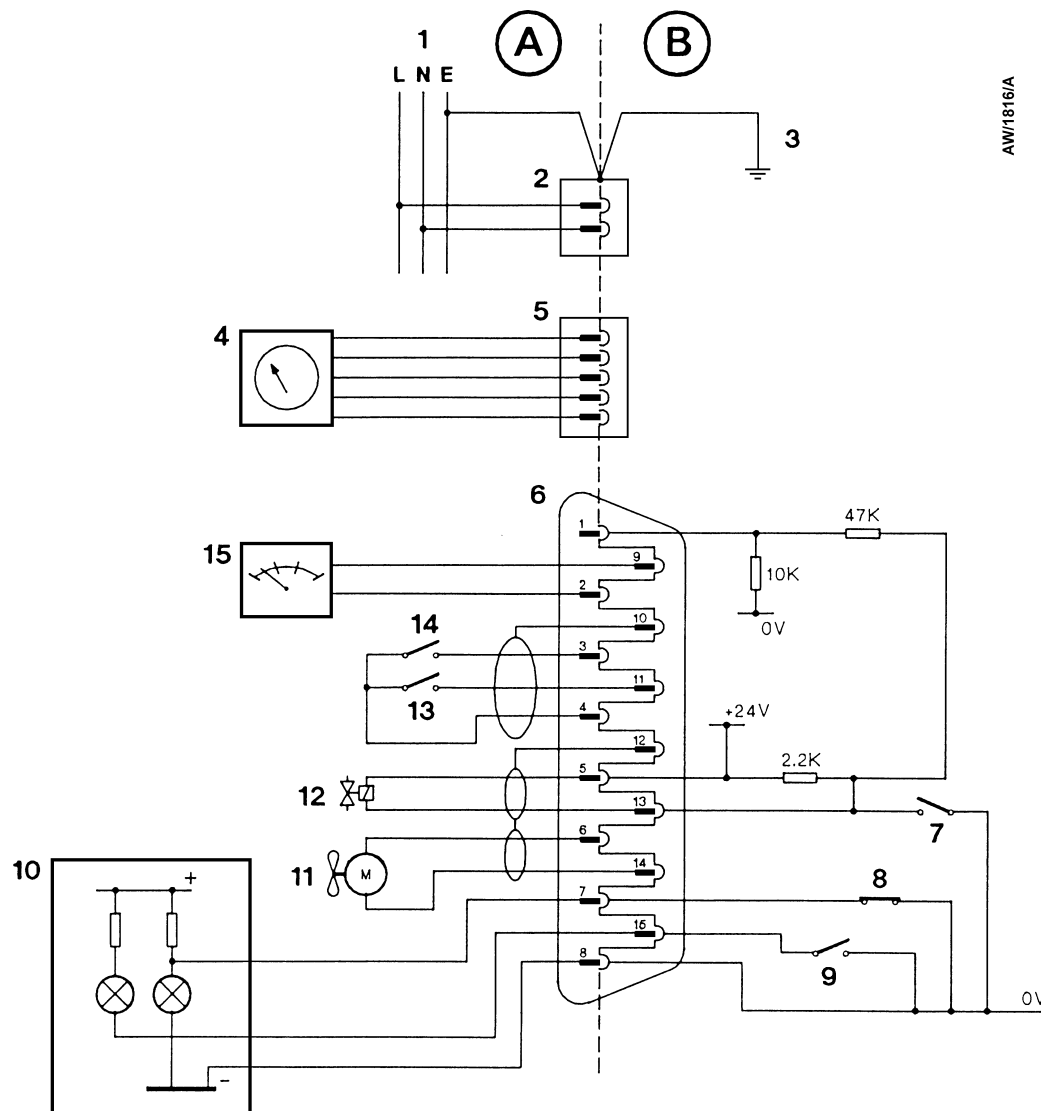

AW/1816/A

- |   |                                  |    |  |     |                                    |
|---|----------------------------------|----|--|-----|------------------------------------|
| A | Vacuum and control system        | 1. | External electrical supply             | 9.  | TMP Normal output (normally open)* |
| B | EXC Controller                   | 2. | Electrical supply connector            | 10. | Remote indicator equipment         |
| L | Live electrical supply           | 3. | Earth (ground)                         | 11. | Air-cooler                         |
| N | Neutral electrical supply        | 4. | AIM active gauge                       | 12. | Vent-valve                         |
| E | Earth (ground) electrical supply | 5. | Active gauge connector                 | 13. | External Standby switch            |
|   |                                  | 6. | Logic interface connector              | 14. | External Start/Stop switch         |
|   |                                  | 7. | Vent-valve control<br>(normally open)* | 15. | Speed/power indicator              |
|   |                                  | 8. | TMP Fail (normally closed)*            |     |                                    |

\* These are solid-state switches in the Controller

Figure 4 - Schematic diagram of Controller electrical connections

### 3.5 Connect the electrical supply

#### WARNING

High voltages exist in the Controller when it is operating. Ensure that the Controller is earthed (grounded) and observe all appropriate safety precautions for the safe installation and handling of electrical equipment. If you do not, there will be a danger of injury or death to people by electric shock.

You must use a suitable electrical supply cable to connect the Controller to the electrical supply. An electrical supply cable is not supplied with the Controller, but is available as an accessory: refer to Section 7.

1. Connect the wires at one end of the electrical supply cable to a suitably rated and fused electrical supply; if required, connect the wires to a suitably rated plug. Connect the wires as shown in Table 4.

Wire colour	Use
Green/yellow	Earth (ground)
Brown	Live (line)
Blue	Neutral

Table 4 - Electrical supply cable wires

2. Fit the connector on the other end of the electrical supply cable to the electrical supply connector on the front of the Controller (see Figure 1).

### 3.6 Connect additional earth (ground) bonding (if required)

Protective earthing (grounding) for electrical safety of the Controller, EXT pump and accessories is provided by the electrical supply cables and connectors and the pump-to-controller cable. However, additional earth (ground) bonding may be required to improve the reliability of the system by reducing any effects of RFI (radio frequency interference), particularly if the vacuum system is prone to high voltage discharges or other radio frequency emissions.

Use good EMC (electromagnetic compatibility) practices and take note of the following EMC earthing (grounding) guidelines to reduce the susceptibility of the system to RFI:

- Connect the Controller, the EXT pump and the vacuum chamber to a common earth (ground) point on the pumping system; this 'star' earth (ground) is typically in the electrical power distribution box.
- Clamp the Controller earthing (grounding) terminal between the two lock-nuts provided on the earth (ground) stud on the rear panel of the Controller.
- Use suitable heavy duty cable or braid to ensure a low impedance bond to the earth (ground) point (typically less than  $0.1 \Omega$  for each leg of the star).
- Use screened cable for all wiring to the logic interface connector. (The TAV5 vent-valve and the ACX Air Cooler accessories are provided with screened cable.) Connect each screen to the Controller earth (ground) stud to ensure that they are properly earthed (grounded).

### 3.7 Connect the EXT pump

If you have an EXC100L Controller, fit the connector on the end of the integral pump-to-controller cable to the connector on the EXT pump.

If you have an EXC100E Controller, use a pump-to-controller cable (not supplied) to connect the Controller to the EXT pump. Fit the connectors on the ends of the cable to the appropriate mating-halves on the rear of the Controller and on the EXT pump.

### 3.8 Connect an AIM Active Inverted Magnetron gauge (optional)

Use an BOC Edwards Active gauge cable (available as an accessory: see Section 7) to connect an BOC Edwards AIM Active Inverted Magnetron Gauge to the Controller through the active gauge connector (Figure 1, item 5) on the rear of the Controller.

If you want to connect another type of gauge to the Controller, connect the gauge to the logic interface: refer to Section 3.9.

## 3.9 Connect the logic interface to your equipment

### 3.9.1 Introduction

#### CAUTION

Do not earth (ground) the logic interface 0 V line (pins 13 and 14). If you do, you will provide an earth (ground) return path for any electrical fault in the pump-motor and this could damage the Controller or your control equipment.

Use the appropriate pins on a suitable mating-plug (not supplied) for the logic interface connector to connect your control equipment and accessories to the Controller, as described in the previous sections and as shown in Table 3 and Figure 4. We recommend that you use wire of 0.24 mm<sup>2</sup> (or smaller) cross-sectional area.

Alternatively, if you do not connect the Controller to your control equipment, link pins 3 and 4 in the mating-plug. The EXT pump will then start to operate as soon as the electrical supply to the Controller is switched on and the pump will stop when the electrical supply to the Controller is switched off.

### 3.9.2 Connect a vacuum gauge to the logic interface

You can connect an BOC Edwards APG Active Pirani Gauge to the Controller so that the setpoint output of the gauge sets the Start/Stop input on the logic interface, to switch on the EXT pump. We recommend that you use the following procedure:

1. Fit an active gauge connector to a suitable break-out box.
2. Connect wires from the break-out box to the logic interface on the Controller, as shown in Table 5.

APG connector pin number	Logic interface pin number
1	6
2	14
3	-
4	-
5	-
6	3

Table 5 - APG to logic interface connections

If you want to connect another type of gauge to the Controller, refer to the instruction manual supplied with your gauge for information on the electrical connections to the gauge.

### 3.10 Adjust the Normal speed

*Note: If you set the Normal speed to be more than 70% of full rotational speed, the TMP Normal output will go high when you select Standby. The Controller is supplied with the Normal speed set to 80% of full rotational speed.*

You can adjust the Normal speed (at which the TMP Normal output goes low: see Section 1.4.4) between 65 and 95% of full rotational speed.

Refer to Figure 5. To adjust the Normal speed, use a small screwdriver to turn the SETPOINT potentiometer (A). Figure 5 also shows the approximate Normal speed settings for different potentiometer adjustments.

### 3.11 Adjust the Internal Timer

The Internal Timer can be adjusted between approximately 1 and 30 minutes. The Controller is supplied with the Internal Timer adjusted to eight minutes (see Section 1.6.2).

To adjust the Internal Timer, use a small screwdriver to turn the TIMER potentiometer (B). Figure 5 also shows the approximate timer settings for different potentiometer adjustments; these settings are only approximate. If the timer setting is critical for your application, you must check the time and readjust the potentiometer as necessary, until the correct time is obtained.

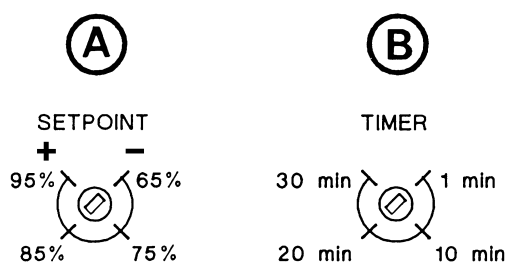
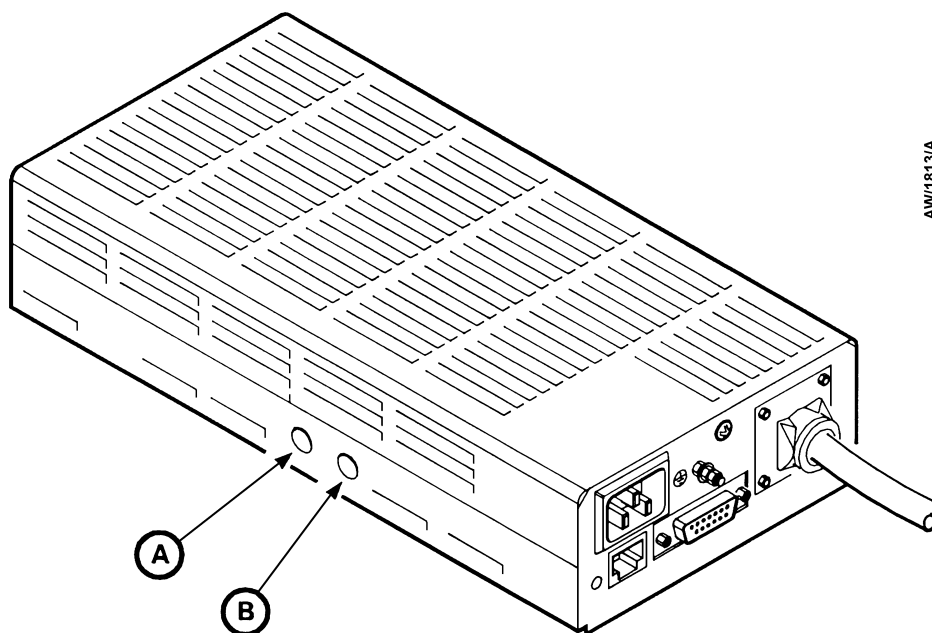

- A Normal speed potentiometer
- B Timer potentiometer

Figure 5 - Normal Speed and Internal Timer potentiometers (EXC100L shown)

## 4 OPERATION

### 4.1 Start-up

*Notes: If you wish, you can start the backing pump and the EXT pump at the same time; the EXT pump will not be damaged and can operate as an effective baffle. However, if the system pressure remains too high for the EXT pump to reach 50% of full rotational speed in the preset time (set by the Internal Timer), the Controller will trip into Fail condition: refer to Section 3.11 for adjustment of the Internal Timer.*

*The following sections assume that you will connect the Controller to your control equipment and use the control input signals on the logic interface connector to operate the pumping system.*

When Start is selected, the Controller will switch on the electrical supply to the EXT pump and the pump rotor will start to accelerate.

Use the following procedure to start up your system. This procedure assumes that you will manually operate the vent-valve and the backing pump, however you can configure the Controller to automatically operate the vent-valve (refer to Section 3.2.4).

1. Close the vent-valve (if fitted).
2. Start the backing pump.
3. Start the EXT pump: close the Start/Stop input on the logic interface (see Section 1.4.3).

### 4.2 Standby

To select Standby, close the Standby input on the logic interface (that is, ensure that the appropriate pins are linked: see Section 1.4.3).

If you select Standby when the pump is operating, the speed of the pump will be reduced to the Standby speed. If you select Standby before you switch the pump on, the pump will run up to Standby speed, not up to full speed.

### 4.3 Operation with high inlet pressure

If the EXT pump inlet pressure rises, the power supplied by the Controller to the pump-motor will increase to counteract the gas frictional load. The pump rotational speed will remain constant until the Controller peak power level is reached; beyond this power level, the speed of the pump will start to reduce.

If the pump speed falls to below 50% of its full rotational speed, the Controller may trip into Fail condition; this depends on how you have configured the Controller (see Sections 1.6 and 3.2).

Refer to the EXT pump instruction manual for the maximum allowable inlet pressure, and refer to Section 2.4 for the maximum Controller output power.

#### 4.4 Operation with high pump temperature

Temperature sensors in the Controller and the EXT pump are monitored by the Controller. If the Controller detects that the pump temperature is too high, the power supplied to the pump-motor is reduced; the pump may not therefore be able to maintain full rotational speed if it is too hot.

If the pump speed falls to below 50% of its full rotational speed, the Controller may immediately trip into Fail condition, or trip into Fail condition after a set time; this depends on how you have configured the Controller (see Sections 1.6 and 3.2).

Refer to the EXT pump instruction manual for the pump operating temperature ranges.

#### 4.5 Normal shutdown

Use the following procedure to shut down your system. This procedure assumes that you will manually operate the vent-valve and the backing pump, however you can configure the Controller to automatically operate the vent-valve (refer to Section 3.2.4). Refer to the Instruction Manual for the EXT pump for details of the maximum allowable vent rate.

1. Select Stop: open the Start/Stop input on the logic interface connector (see Section 1.4.3).
2. Open the vent-valve before the EXT pump speed is below 50% of full rotational speed.
3. Switch off the backing pump.

#### 4.6 Automatic shutdown after Fail condition

##### WARNING

If the Start/Stop control signal on the logic interface connector is set to Start, the Controller will automatically restart the EXT pump when the electrical supply is restored after an electrical supply failure. Ensure that people cannot be injured by the rotating rotor blades of the EXT pump.

The Controller will automatically switch off the electrical supply to the EXT pump if the Controller trips into Fail condition (see Section 1.6).

The operation of the vent-valve in all Fail conditions depends on how you have configured the Controller: refer to sections 1.6 and 3.2.

#### 4.7 Reset the Controller after Fail condition

To reset a Fail condition, open the Start/Stop input on the logic interface for at least 300 ms and then close the input.

## 4.8 Electrical supply failure

If the electrical supply to the Controller fails when the EXT pump is rotating:

- The motor of the EXT pump is used as a generator and the electrical supplies for the vent-valve, air-cooler and AIM gauge (if connected) and the associated control logic are maintained until the pump speed falls to 50% of full rotational speed, then the electrical supplies are switched off.
- The Controller will then shut down.

## 5 Maintenance

### 5.1 Safety

**WARNING**

Obey the safety instructions given below and take note of appropriate precautions. If you do not, you can cause injury to people and damage to equipment.

- A suitably trained and supervised technician must maintain the Controller.
- Isolate the Controller and other components in the pumping system from the electrical supply so that they cannot be operated accidentally.
- Dispose of components safely (see Section 6.2).

### 5.2 Replace a fuse

#### 5.2.1 Introduction

If the electrical supply fuse fails immediately after you have replaced it, determine the cause of the failure and rectify the fault before you use the Controller.

#### 5.2.2 Replace the electrical supply fuse

1. Refer to Figure 3. Undo and remove the two screws (1) and remove the top cover (2) of the Controller.
2. Remove the fuse holder (3), remove and discard the failed fuse.
3. Insert a new fuse of the correct rating (refer to Section 2.3) and refit the fuse holder.
4. Refit the top cover (2) and secure with the two screws (1).

### 5.3 Clean the Controller

If necessary, use a soft dry cloth to clean the exterior of the Controller.

If you need to clean the interior of the Controller, we recommend that you return the Controller to your supplier or your nearest BOC Edwards Service Centre.

### 5.4 Fault finding

If the Controller shuts down because of Fail condition, refer to the appropriate sections of this manual to determine the cause of the Fail condition. If necessary, refer to the appropriate fault finding section of the instruction manual supplied with the EXT pump.

## 6 STORAGE AND DISPOSAL

### 6.1 Storage

Fit protective covers over the electrical connections and store the Controller in clean dry conditions until required.

When required for use, prepare and install the Controller as described in Section 3 of this manual.

### 6.2 Disposal

**WARNING**

Do not incinerate the Controller. If you do, you may cause injury to people.

Dispose of the Controller and any components safely in accordance with all local and national safety and environmental requirements.

Do not incinerate the Controller. If the Controller is heated to very high temperatures, dangerous gases may be emitted and internal components may explode.

## 7 SERVICE, SPARES AND ACCESSORIES

### 7.1 Introduction

BOC Edwards products, spares and accessories are available from BOC Edwards companies in Belgium, Brazil, Canada, France, Germany, Hong Kong, Italy, Japan, Korea, Switzerland, United Kingdom, U.S.A and a world-wide network of distributors. The majority of these centres employ Service Engineers who have undergone comprehensive BOC Edwards training courses.

Order spare parts and accessories from your nearest BOC Edwards company or distributor. When you order, please state for each part required:

- Model and Item Number of your equipment
- Serial number (if any)
- Item Number and description of the part.

### 7.2 Service

BOC Edwards products are supported by a world-wide network of BOC Edwards Service Centres. Each Service Centre offers a wide range of options including: equipment decontamination; service exchange; repair; rebuild and testing to factory specifications. Equipment which has been serviced, repaired or rebuilt is returned with a full warranty.

Your local Service Centre can also provide BOC Edwards engineers to support on-site maintenance, service or repair of your equipment.

For more information about service options, contact your nearest Service Centre or other BOC Edwards company.

### 7.3 Accessories

#### 7.3.1 Electrical supply cable

You must use a suitable electrical supply cable to connect the Controller to your electrical supply. An electrical supply cable is not supplied with the Controller.

<b>Cable</b>	<b>Item Number</b>
Electrical supply cable (2 m length, unterminated)	D385-01-102

### 7.3.2 Pump-to-controller cable

A pump-to-controller cable must be used with each pump. It is not supplied with the EXT pump or with the EXC100E Controller. The following cables are available:

<b>Cable</b>	<b>Item Number</b>
Pump-to-controller cable, 1 m	D396-18-010
Pump-to-controller cable, 3 m	D396-18-030
Pump-to-controller cable, 5 m	D396-18-050
Pump-to-controller cable (OEM *), 5 m	D396-20-325

\* The OEM cable is supplied with a separate connector so that you can fit the cable through a bulkhead, if required.

### 7.3.3 BX bakeout band

A BX bakeout band accelerates the degassing of the pump to enable it to achieve lower pressures. It may also be used to protect the pump from condensation of contaminants. The bakeout bands are available in 110-120 V or 220-240 V versions. You must provide an external electrical supply to power the bakeout band; you cannot power it from the Controller.

<b>Bakeout band</b>	<b>Voltage</b>	<b>Item Number</b>
BX70	110 V	B580-52-040
BX70	240 V	B580-52-060
BX250	110 V	B580-52-041
BX250	240 V	B580-52-061
BX351	110 V	B580-52-042
BX351	240 V	B580-52-062

### 7.3.4 TAV vent-valve

A solenoid-operated vent-valve is available for system venting. The valve is 24 V d.c. 2 W, normally-open, and can be operated automatically from the EXC Controller. The solenoid-valve is fitted in place of the manual vent-valve, or alternatively can be fitted with an adaptor (supplied with the valve) and used with any suitable NW10 flanged port on your vacuum system.

<b>Vent-valve</b>	<b>Item Number</b>
TAV5 vent-valve	B580-66-010

### 7.3.5 ACX air-cooler

An ACX air-cooler can be fitted to the EXT pump and can be operated automatically from the Controller. However, please refer to Section 3 of the instruction manual for the EXT pump to check the suitability of air cooling in a particular application.

<b>Air-cooler</b>	<b>Item Number</b>
ACX70	B580-53-050
ACX250	B580-53-150
ACX350/500	B580-53-200

### 7.3.6 Active vacuum gauges

Examples of suitable gauges and accessories which you can connect to the EXC Controllers are listed below. Note that you can only connect an AIM gauge directly to the active gauge connector on the Controller; you must connect other gauges through the logic interface: refer to Section 3.9.

<b>Description</b>	<b>Item Number</b>
AIM-S-NW25 Active Inverted Magnetron Gauge	D145-45-000
AIM-SL-NW25 Active Inverted Magnetron Gauge	D145-48-000
APG-M-NW16 Active Pirani Gauge	D021-71-000
APG-L-NW16 Active Pirani Gauge	D021-73-000
ATC-E Active Thermocouple Gauge	D351-08-000
ATC-D $\frac{1}{8}$ inch NPT Thermocouple Gauge Tube	D351-12-000
ATC-M $\frac{1}{8}$ inch NPT Thermocouple Gauge Tube	D351-13-000
Active Gauge Cable, 0.5 m long	D400-01-005
Active Gauge Cable, 1 m long	D400-01-010
Active Gauge Cable, 3 m long	D400-01-030

## 8 ENGINEERING DIAGRAMS

To assist in fault finding (refer to Section 5), the connections between the Controller and the EXT pump are shown in Figure 6.

The Active Gauge connector (which is specific to the EXC Controller) is shown in Figure 7.

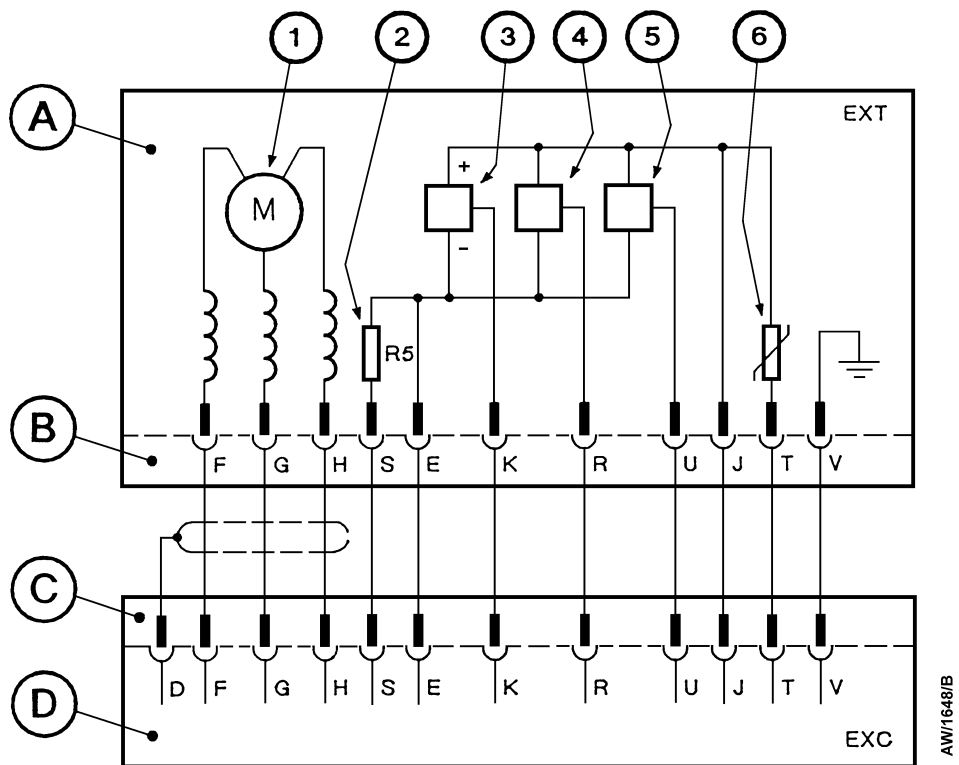

- |   |                         |    |                         |
|---|-------------------------|----|-------------------------|
| A | EXT pump                | 1. | DC motor                |
| B | EXT connector on cable  | 2. | Speed set resistor      |
| C | EXC connector on cable* | 3. | Hall effect device 1    |
| D | EXC Controller          | 4. | Hall effect device 2    |
|   |                         | 5. | Hall effect device 3    |
|   |                         | 6. | Pump temperature sensor |

\* EXC100E controller only; the EXC100L has an integral cable

Figure 6 - EXC Controller to EXT pump connections

AWI1574/A

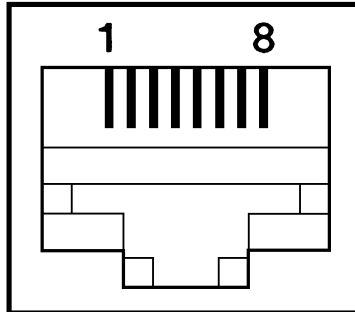

Figure 7 - Active gauge connector pins

Pin	Signal
1	Power supply +24 V d.c.
2	Power supply 0 V d.c.
3	Not used
4	Gauge identification signal
5	Not used
6	Not used
7	TMP Normal status output
8	Not used

Table 6 - Active gauge connector pins

