

Instruction Manual

EXT Turbomolecular Pumps EXT70 and EXT250

Description

*EXT70/NW40
EXT70/NW50
EXT70/ISO63
EXT70/63CF
EXT250/ISO100
EXT250/100CF*

Item Number

*B722-03-000
B722-04-000
B722-01-000
B722-02-000
B736-01-000
B736-02-000*



Declaration of Conformity

We, BOC Edwards,
Manor Royal,
Crawley,
West Sussex RH10 2LW, UK

declare under our sole responsibility that the product(s)

EXT70 and EXT250 Turbomolecular Pumps:

EXT70/ISO63	B722-01-000/B722-05-000		
EXT70/NW50	B722-04-000		
EXT70/63CF	B722-02-000	EXT250/ISO100	B736-01-000
EXT70/NW40	B722-03-000	EXT250/100CF	B736-02-000

to which this declaration relates is in conformity with the following standard(s)
or other normative document(s):

EN ISO12100-2: 2003	Safety of machinery. Basic concepts, general principals for design. Technical principals.
EN61010-1: 2001	safety requirements for electrical equipment for measurement, Control and laboratory use. General requirements.*
EN1012-2: 1997	Compressors and vacuum pumps. Safety requirements. Vacuum pumps.
EN61326: 1997	Electrical equipment for measurement, control and laboratory use.
+ A1: 1998 + A2: 2001	EMC requirements.
(Industrial Location, Class B Emissions)	

* The pumps comply with EN61010-1 (2001) when installed in accordance with the instruction manual supplied with the pumps.

following the provisions of:

73/023/EEC	Low Voltage Directive.
89/336/EEC	Electromagnetic Compatibility Directive.
98/37/EC	Machinery Safety Directive.



Dr J. D. Watson, Technical Director
Vacuum Equipment and Exhaust Management Product Divisions

1 December 2004 Storrham

Date and Place

This product has been manufactured under a quality system registered to ISO9001

 **BOC EDWARDS**

CONTENTS

Section	Title	Page
1	INTRODUCTION	1
1.1	Scope and definitions	1
1.2	General description	2
1.3	Vent options and vent control	5
2	TECHNICAL DATA	6
2.1	General	6
2.2	Pumping media	6
2.2.1	EXT70 and EXT250 pumps without gas purge	7
2.2.2	EXT250 pumps with gas purge	7
2.3	Vent gas specification and vent control data	7
2.4	Purge gas specification (for EXT250 only)	9
2.5	Cooling-water	9
3	INSTALLATION	12
3.1	Unpack and inspect	12
3.2	Typical installation	12
3.3	Connect to the vacuum system	14
3.3.1	Inlet-screen	14
3.3.2	Mechanical fixing	15
3.3.3	Base mounting	15
3.3.4	Inlet connection and orientation	16
3.3.5	Backing connection	16
3.4	Vent-valve connection and control	17
3.5	Purge gas connection (EXT250 only)	18
3.5.1	Connect the purge gas	18
3.5.2	Recommended purge gas flow	18
3.6	Electrical installation	18
3.7	Cooling	19
3.7.1	Forced-air cooling	19
3.7.2	Water-cooling	19
4	OPERATION	21
4.1	Start-up	21
4.2	Stand-by	21
4.3	Shut-down	22
4.4	Safety interlocks and control system	22
4.5	Bakeout	23
5	MAINTENANCE	24
5.1	Introduction	24
5.2	Bearing life	24
5.3	Rotor life	24
5.4	Clean the pump	25
5.5	Fault finding	26

Section	Title	Page
6	STORAGE AND DISPOSAL	29
6.1	Storage	29
6.2	Disposal	29
7	SERVICE, SPARES AND ACCESSORIES	30
7.1	Introduction	30
7.2	Service	30
7.3	Spares	30
7.3.1	ISX inlet-screen	30
7.3.2	WCX water-cooler	30
7.3.3	Inlet-flange seals	31
7.4	Accessories	31
7.4.1	Installation	31
7.4.2	EXC Controller	31
7.4.3	Pump-to-controller cable	31
7.4.4	BX bakeout band	32
7.4.5	FL20K foreline trap	32
7.4.6	TAV vent-valve and vent-port adaptor	32
7.4.7	ACX air-cooler	32
7.4.8	Vibration isolators	34
7.4.9	PRX purge restrictor	34
7.4.10	VRX vent-restrictor	34

RETURN OF BOC EDWARDS EQUIPMENT

Illustrations

Figure	Title	Page
1	Cross-section view of EXT70 Turbomolecular Pump	3
2	Cross-section view of EXT250 Turbomolecular Pump	4
3	Maximum allowed rate of pressure rise during venting	9
4	EXT70 Turbomolecular Pump dimensions (mm)	10
5	EXT250 Turbomolecular Pump dimensions (mm)	11
6	Typical pumping system	13
7	Correct installation of the inlet-screen	14
8	Installation of optional accessories (and spares)	33

Tables

Table	Title	Page
1	Technical data	8
2	Checklist of items	12
3	Vent-valve orifice diameter	17
4	Pump cooling methods for different applications	20
5	Fault finding	26

Associated publications

Publication title	Publication Number
EXT Pump Accessories	D580-66-880
EXC Controllers	D396-14-880

This page intentionally blank.

1 INTRODUCTION

1.1 Scope and definitions

This manual provides installation, operation and maintenance instructions for the BOC Edwards EXT70 and EXT250 Turbomolecular Pumps. You must use the Pumps as specified in this manual.

The EXT Turbomolecular Pumps are designed for use with a BOC Edwards EXC Controller. Read this manual and the instruction manual supplied with your EXC Controller before you attempt to install or operate the equipment. The EXC Controller instructions contain details of how to set up a pumping system and how to control accessories such as an air-cooler, vent-valve and bakeout band.

Important safety information in this manual is highlighted as WARNING and CAUTION instructions; you must obey these instructions. The use of WARNINGS and CAUTIONS is defined below.

WARNING

Warnings are given where failure to observe the instruction could result in injury or death to people.

CAUTION

Cautions are given where failure to observe the instruction could result in damage to the equipment, associated equipment and process.

In accordance with the recommendations of EN61010, the following warning symbols may appear on the pump or its accessories:



Caution - refer to accompanying documents.



Caution - hot surface.



Caution - risk of electric shock.



Protective conductor terminal.

The units used throughout this manual conform to the SI international system of units of measurement. Where nitrogen purge flow rates are specified, the abbreviation 'sccm' is used to mean 'standard $\text{cm}^3 \text{min}^{-1}$ ': this is a flow of $1 \text{ cm}^3 \text{min}^{-1}$ at an ambient temperature of 0°C and at an ambient pressure of 1013 mbar ($1.013 \times 10^5 \text{ Pa}$).

1.2 General description

The EXT turbomolecular pumps are multi-stage axial-flow turbines, optimised for operation in molecular flow conditions. The internal structures of the EXT70 and EXT250 Turbomolecular Pumps are shown in Figures 1 and 2.

The multi-stage, light alloy turbine rotor (12) is machined from one piece to form rows of angled blades fitted to a central shaft (6). The blades of the rotor rotate between the blades of the stator. The stator assembly (11) is a series of thin disks separated by spacer rings (10). The blades are angled so that the gas in the vacuum chamber is compressed and is transferred from the pump-inlet to the outlet.

The rotor and stator blades have an open structure at the pump-inlet and a more closed structure at the outlet. This configuration gives an optimum combination of pumping speed and compression when the pump is operated with gases of both high and low molecular weight.

The rotor is driven by a high-efficiency, brushless d.c. motor. The motor (7) has a magnetized rotor fitted onto the shaft, and a wound stator located in the pump-body. For the blades to be effective, their speed must be close to the thermal velocity of the gas molecules. The rotor is therefore rotated at up to 90000 r min^{-1} .

The rotor assembly is supported at the inlet end by a frictionless magnetic bearing (3) and by a precision ball bearing (8) at the outlet end. The ball bearing is lubricated from an oil reservoir and wick mechanism (9).

EXT pumps are supplied with an inlet-screen (2) fitted in the bore of the inlet-flange. The inlet-screen protects you from the sharp blades and also protects the pump against damage caused by debris which falls into the pump.

EXT pumps have a vent-port which you can use to vent the pump and your vacuum system to atmospheric pressure. The vent-port introduces vent gas part way up the pump rotor to ensure maximum cleanliness even with fluoroelastomer sealed vent-valves. The pump is supplied with a manual vent-valve fitted to the vent-port. As described in Section 3.4, you can replace the manual vent-valve with a TAV5 solenoid-operated vent-valve (available as an accessory: see Section 7).

The EXT250 pump has a purge-port (Figure 5, item 1) in the motor and bearing housing chamber. You can introduce an inert purge gas through the purge-port to protect the bearing lubricant from the effects of high oxygen concentrations. You can fit an optional purge restrictor to the purge-port to control the flow rate of the purge gas and to filter the gas supply (see Section 7).

Electrical connection between the EXT and the EXC Controller is by a 19-way connector and a pump-to-controller cable. The cable is a separate item and is available in a choice of lengths (see Section 7 for details).

The pump may be air-cooled using an optional air-cooler accessory, or water-cooled by passing water through the water-cooler provided. Two ruffled hose connectors are provided for connection of your cooling-water supply and return pipelines. The EXT70 may be cooled by natural convection to the surrounding air. A thermal sensor monitors the temperature of the motor and the pump-body.

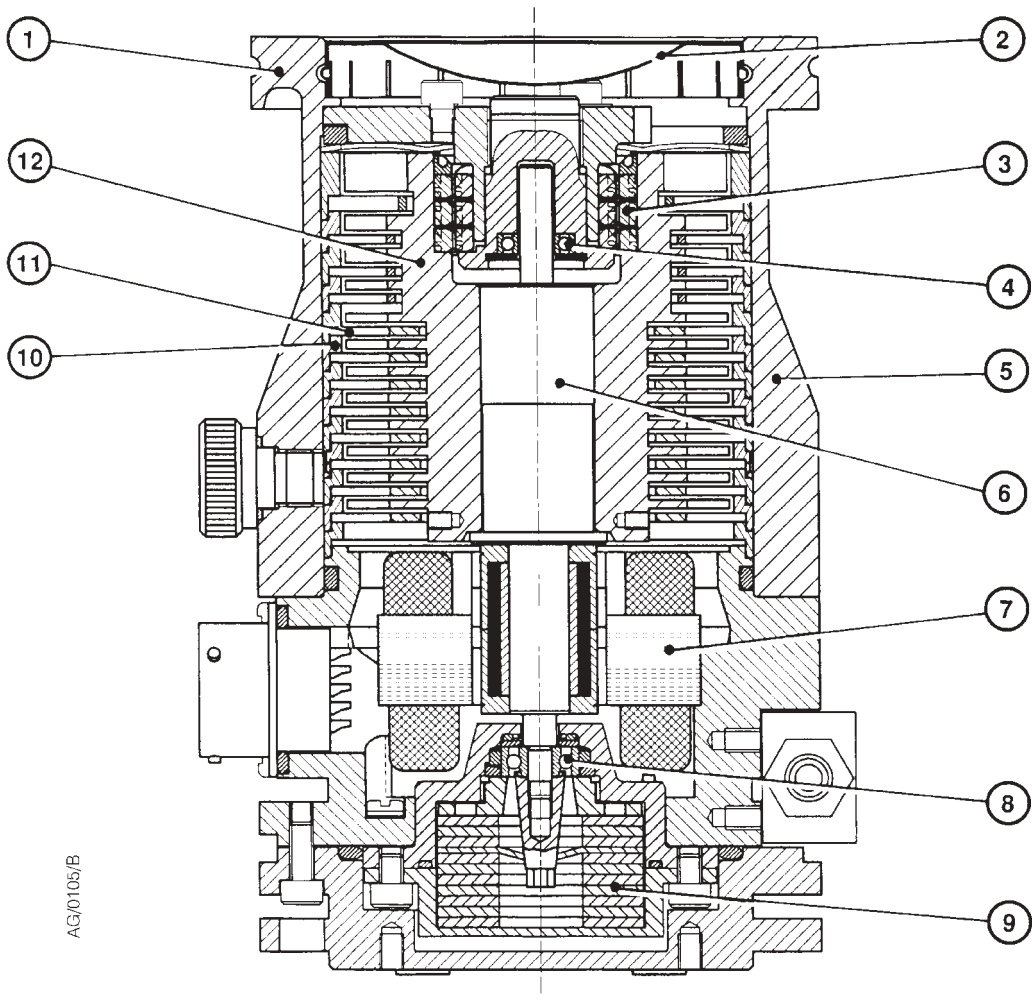

AG/0105/B

- | | |
|---------------------|------------------|
| 1. Inlet-flange | 7. DC motor |
| 2. Inlet-screen | 8. Lower bearing |
| 3. Magnetic bearing | 9. Oil reservoir |
| 4. Safety bearing | 10. Spacer ring |
| 5. Envelope | 11. Stator |
| 6. Shaft | 12. Rotor |

Figure 1 - Cross-section view of EXT70 Turbomolecular Pump

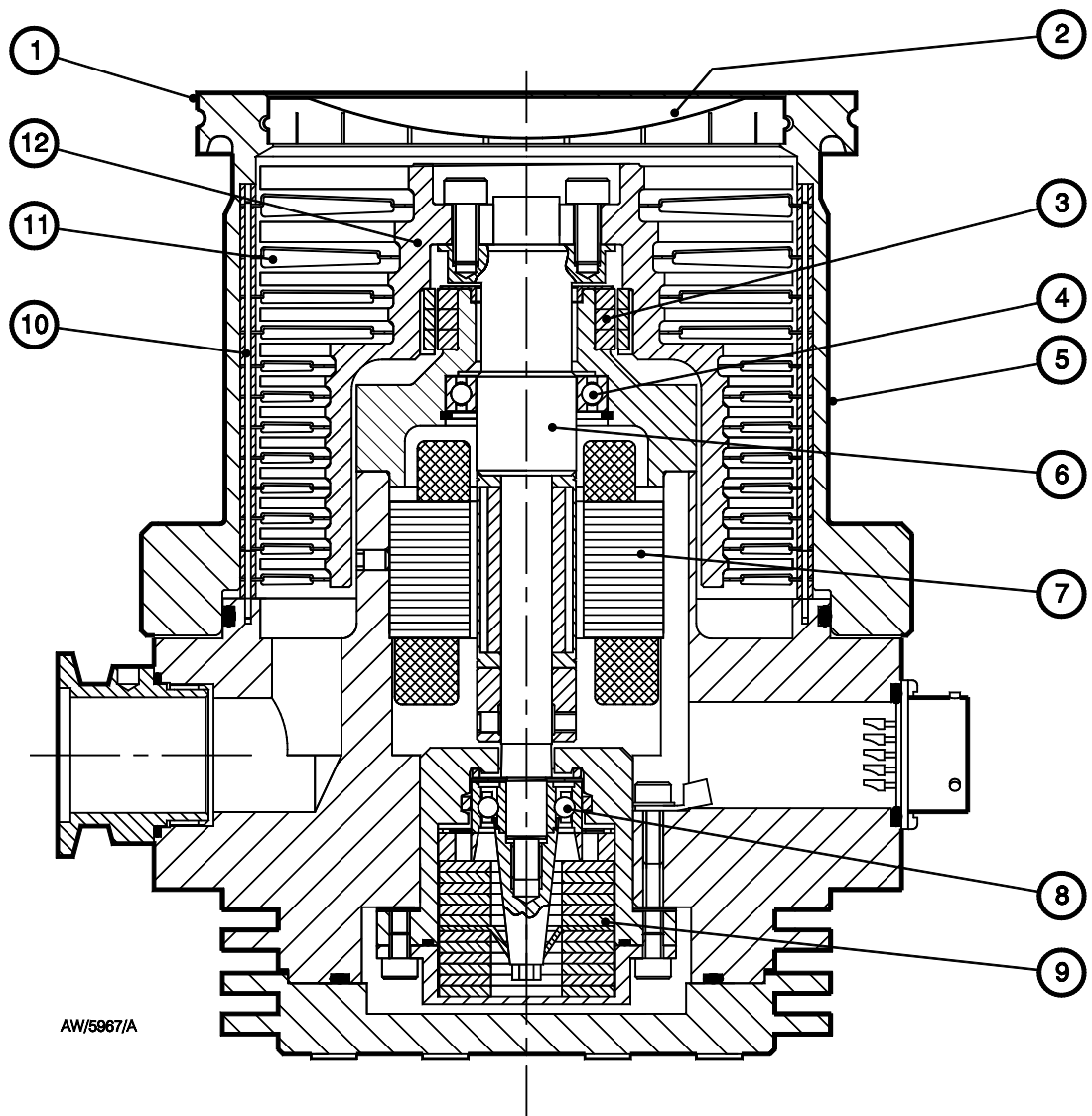

- | | |
|---------------------|------------------|
| 1. Inlet-flange | 7. DC motor |
| 2. Inlet-screen | 8. Lower bearing |
| 3. Magnetic bearing | 9. Oil reservoir |
| 4. Safety bearing | 10. Spacer ring |
| 5. Envelope | 11. Stator |
| 6. Shaft | 12. Rotor |

Figure 2 - Cross-section view of EXT250 Turbomolecular Pump

1.3 Vent options and vent control

To maintain the cleanliness of your vacuum system, we recommend that, whenever you switch the pump off, you vent the pump (or vacuum system) when the speed of the EXT pump is between full rotational speed and 50% of full rotational speed. At and above 50% of full rotational speed, the rotor spins fast enough to suppress any backstreaming of hydrocarbon oil from your backing pump.

However, if you vent the pump when it is at full rotational speed and the rate of pressure rise is too high, the pump life may be reduced. We therefore recommend that you either limit the rate of pressure rise in accordance with Figure 3, or only open the vent-valve after the EXT pump speed has fallen to 50% of full rotational speed.

The rate of pressure rise cannot be controlled by the manual vent-valve, so if you use the manual vent-valve, you must only open the vent-valve after the EXT pump speed has fallen to 50% of full rotational speed.

If you use a TAV5 vent-valve, but you cannot limit the rate of pressure rise, you must only open the vent-valve after the EXT pump speed has fallen to 50% of full rotational speed. If you use the EXC Controller to control your TAV5 vent-valve, configure the Controller to select this option: refer to Section 3.4 for more information. The EXC Controller is factory set to vent when the EXT pump is at 50% of full rotational speed after you have selected Stop.

2 TECHNICAL DATA

2.1 General

Performance	See Table 1
Dimensions	See Figures 4 and 5
Maximum inlet-flange temperature	100 °C
Maximum magnetic field	5 mT
Ambient operating temperature *	5 to 40 °C
Maximum operating humidity	
Ambient temperature up to 31 °C	80%
Ambient temperature up to 40 °C	50%
Maximum operating altitude	2000 m
Installation category	EN61010 part 1, Category 1
Pollution degree	EN61010 part 1, Category 2
Equipment type	Fixed Equipment, for indoor use only

* For water-cooled pumps. See Table 1 for forced-air and ambient air-cooled pumps.

2.2 Pumping media

WARNING

Vent dangerous gases and gas mixtures safely. Do not expose people to these gases.

WARNING

Do not use EXT pumps to pump explosive gas mixtures as the pumps are not suitable for this purpose.

CAUTION

Do not use an EXT to pump gases containing more than 20% oxygen unless the pump is gas purged. If you do, the lubricant will polymerise and the pump will fail prematurely.

CAUTION

Do not use the EXT to pump mercury vapour and do not allow mercury (for example, from a McLeod gauge) to come into contact with the pump. If you do, the pump rotor may corrode and fail.

Note that concentrations of gases may be modified by the compression of the pump.

2.2.1 EXT70 and EXT250 pumps without gas purge

These pumps are designed to pump the following residual gases normally used in high-vacuum systems :

- Air
- Carbon dioxide
- Carbon monoxide
- Helium
- Krypton
- Neon
- Argon
- Hydrogen
- Ethane
- Propane
- Butane
- Methane

You can use the pumps to pump oxygen and water vapour, subject to the following conditions :

- Oxygen The oxygen concentration must be less than 20% by volume.
- Water vapour You must ensure that vapour does not condense inside the pump; refer to Section 3.7.1.

If you wish to pump a gas not in the list above, contact your supplier for advice. If you do not contact your supplier, you may invalidate the warranty on the pump. EXT70 and EXT250 pumps are not suitable for pumping aggressive or corrosive gases.

2.2.2 EXT250 pumps with gas purge

When purged with an inert gas, EXT250 pumps can be used to pump oxygen in concentrations above 20% by volume.

2.3 Vent gas specification and vent control data

Although the pump may be vented to atmospheric air, high relative humidity of the air may greatly increase the subsequent pumping time. To reduce pump-down times you should vent the pump with dry, clean gases.

Vent gas	Dry air, nitrogen, argon or other inert gases
Maximum dew point at atmospheric pressure	- 22 °C
Maximum size of particulates	1µm
Maximum concentration of oil	0.1 parts per million
Maximum allowed rate of pressure rise	See Figure 3

Parameter	Pump → Units ↓	EXT70	EXT70	EXT70	EXT250
Mass	kg	1.4	1.4	3.4 (CF), 1.5 (ISO)	5.6 (CF), 8.0 (ISO)
Inlet-flange		DN40NW	DN50NW	DN63CF DN63ISO-K	DN100CF DN100ISO-K
Outlet-flange		DN16NW	DN16NW	DN16NW	DN25NW
Vent-port		1/8 inch BSP	1/8 inch BSP	1/8 inch BSP	1/8 inch BSP
Purge-port		-	-	-	DN10NW
Pumping speed N ₂ †	l s ⁻¹	52	60	65	240
He †	l s ⁻¹	53	56	60	250
H ₂ †	l s ⁻¹	46	48	50	190
Compression ratio N ₂		> 1 × 10 ⁸	> 1 × 10 ⁸	> 1 × 10 ⁸	> 1 × 10 ⁸
He		6000	6000	6000	2 × 10 ⁴
H ₂		500	500	500	1500
Ultimate pressure *	mbar	< 5 × 10 ⁻⁹	< 5 × 10 ⁻⁹	< 5 × 10 ⁻¹⁰ (CF) < 5 × 10 ⁻⁹ (ISO-K)	< 5 × 10 ⁻¹⁰ (CF) < 5 × 10 ⁻⁹ (ISO-K)
	Pa	< 5 × 10 ⁻⁷	< 5 × 10 ⁻⁷	< 5 × 10 ⁻⁸ (CF) < 5 × 10 ⁻⁷ (ISO-K)	< 5 × 10 ⁻⁸ (CF) < 5 × 10 ⁻⁷ (ISO-K)
Minimum backing pump displacement	m ³ h ⁻¹	0.6	0.6	1.3	4.5
Maximum continuous inlet pressure (water-cooling at 15 °C) §					
EXC100/120	mbar/Pa	9 × 10 ⁻¹ / 9 × 10 ¹	9 × 10 ⁻¹ / 9 × 10 ¹	9 × 10 ⁻¹ / 9 × 10 ¹	1 × 10 ⁻¹ / 1 × 10 ¹
EXC300	mbar/Pa	9 × 10 ⁻¹ / 9 × 10 ¹	9 × 10 ⁻¹ / 9 × 10 ¹	9 × 10 ⁻¹ / 9 × 10 ¹	3 × 10 ⁻¹ / 3 × 10 ¹
Maximum continuous inlet pressure (air-cooling at 35 °C) §	mbar/Pa	9 × 10 ⁻² / 9 × 10 ⁰	9 × 10 ⁻² / 9 × 10 ⁰	9 × 10 ⁻² / 9 × 10 ⁰	3 × 10 ⁻² / 3 × 10 ⁰
Maximum continuous inlet pressure (free convection at 35 °C) §	mbar/Pa	9 × 10 ⁻³ / 9 × 10 ⁻¹	9 × 10 ⁻³ / 9 × 10 ⁻¹	9 × 10 ⁻³ / 9 × 10 ⁻¹	-
Recommended backing pump †		E2M0.7	E2M0.7	E2M1.5	E2M5
Operating attitude		Vertical and upright through to horizontal	Vertical and upright through to horizontal	Vertical and upright through to horizontal	Vertical and upright through to horizontal
Nominal rotational speed	r min ⁻¹	90000	90000	90000	60000
Standby rotational speed	r min ⁻¹	63000	63000	63000	42000
Starting time to 90% speed					
EXC120/120E	sec	90	90	90	100
EXC300	sec	90	90	90	90
Cooling method		Free convection/forced-air/water	Free convection/forced-air/water	Free convection/forced-air/water	Forced-air/water
Ambient air temperature ▲					
Free convection	°C	0 - 30	0 - 30	0 - 30	-
Forced-air	°C	0 - 35	0 - 35	0 - 35	0 - 35
Water temperature	°C	10 - 20	10 - 20	10 - 20	10 - 20
Noise level (at 1 metre)	dBA	< 50	< 50	< 50	< 50
Recommended controller		EXC100/120	EXC100/120	EXC100/120	EXC100/120
EXC120/E maximum VA input (including heater band)	VA	250	250	250	250
EXC120/E normal power	VA	60	60	60	60
Other compatible controller		EXC300	EXC300	EXC300	EXC300
EXC300 maximum VA input (including heater band)	VA	480	480	480	480
EXC300 normal power	VA	60	60	60	60
Quiescent power consumption	W	10	10	10	25

† Pumping speeds are without inlet-screen. Inlet-screens are supplied fitted and reduce speed by approximately 10%.

* Ultimate pressure 48 hours after bakeout with 2-stage rotary vane backing-pump.

§ Above this pressure, rotational speed drops below nominal.

† A larger backing-pump may be required for maximum throughput.

▲ Forced-air cooled pumps and ambient air-cooled pumps.

Table 1 - Technical data

2.4 Purge gas specification (for EXT250 only)

Purge gas	Dry nitrogen, argon or other inert gases
Maximum dew point at atmospheric pressure	-22 °C
Maximum size of particulates	1 µm
Maximum concentration of oil	0.1 parts per million
Allowable purge gas flow (when required)	20 to 100 sccm (0.33 to 1.67 mbar l s ⁻¹ , 33 to 167 Pa l s ⁻¹)
Recommended purge gas flow	25 sccm (0.42 mbar l s ⁻¹ , 42 Pa l s ⁻¹)
Maximum allowable purge gas supply pressure	2 bar gauge, 29 psig, 3 x 10 ⁵ Pa

2.5 Cooling-water

The following cooling-water specification corresponds to a typical high-quality drinking water specification. Check with your water supply authority if you are in doubt about the quality of your supply.

Quality	Mechanically clean and optically clear with no deposits or turbidity.
pH value	6.0 to 8.0
Maximum calcium carbonate concentration	75 parts per million
Maximum chloride concentration	100 parts per million
Minimum oxygen concentration	4 parts per million
Minimum water-cooling flow rate (at 15 °C)	15 l h ⁻¹
Water temperature	See Table 1
Maximum water pressure	5 bar gauge, 72 psig, 6 x 10 ⁵ Pa

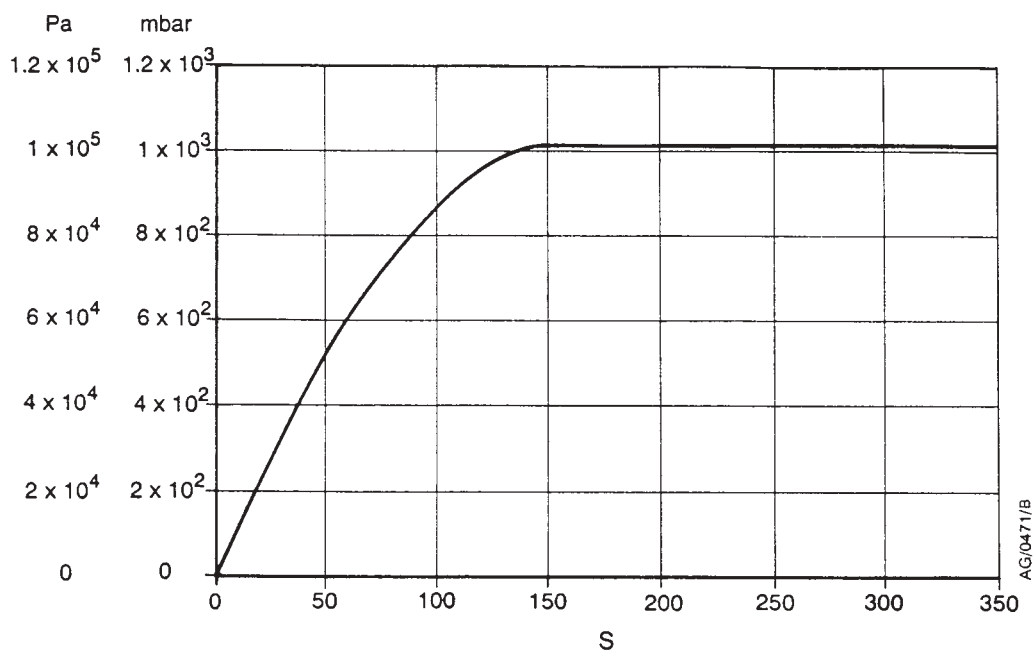
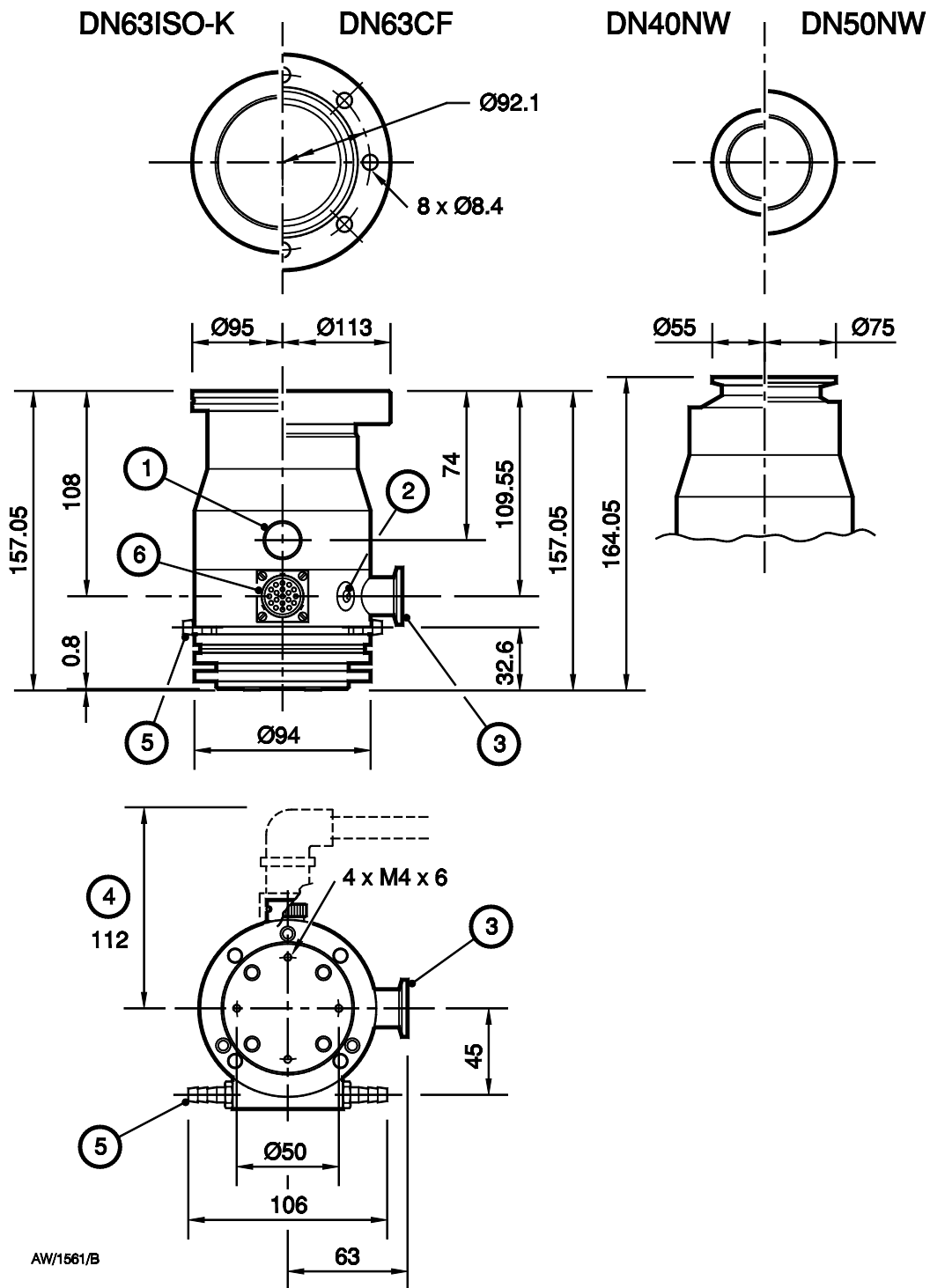
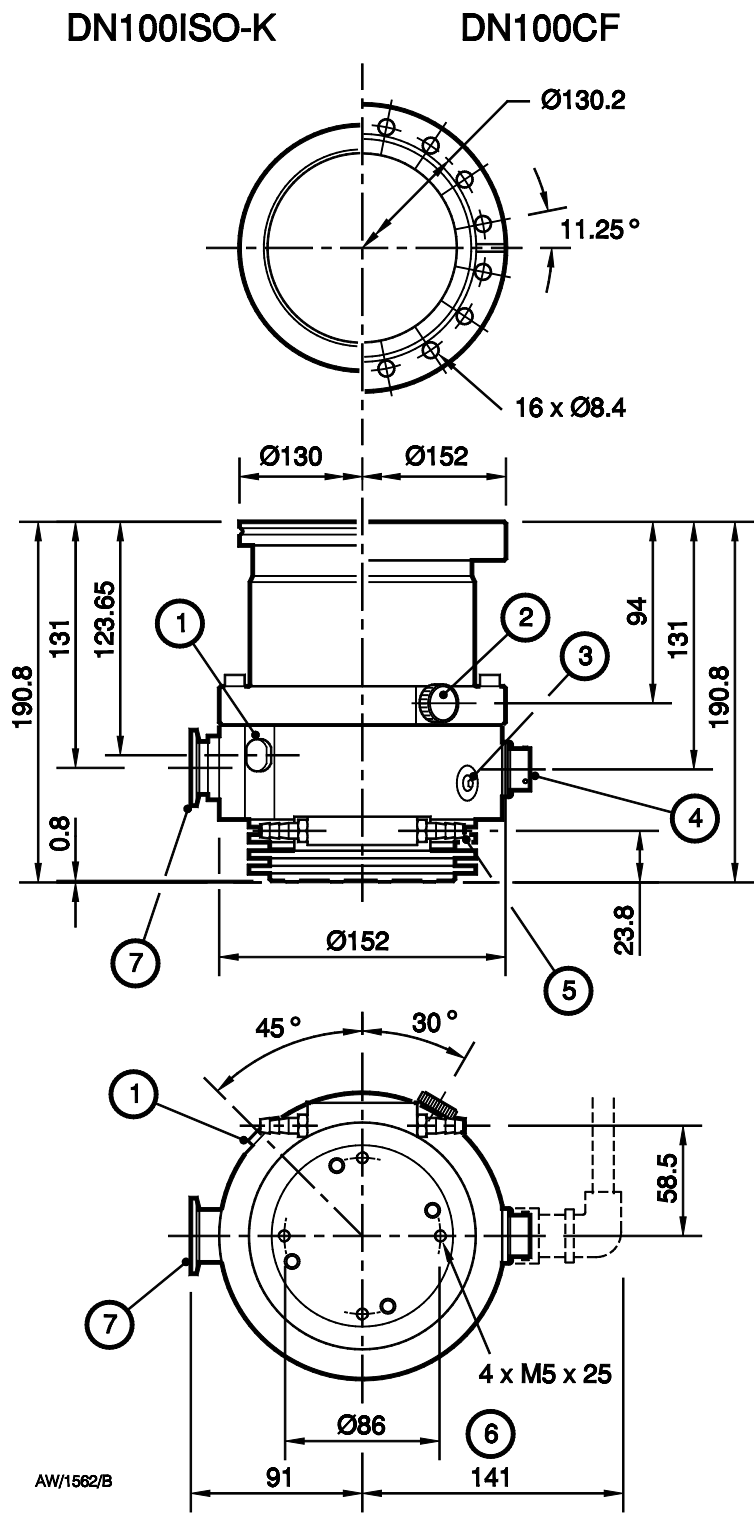

Figure 3 - Maximum allowed rate of pressure rise during venting: system pressure (Pa/mbar, with the backing pump isolated) against time (s), with the pump initially at full rotational speed



- | | |
|-------------------------|--|
| 1. Vent-valve | 4. Allowance for right-angle cable connector |
| 2. Earth (ground) screw | 5. Cooling-water connectors |
| 3. Backing-port | 6. Electrical supply connector |

Figure 4 - EXT70 Turbomolecular Pump dimensions (mm)



- | | |
|--------------------------------|--|
| 1. Purge plug in purge-port | 5. Cooling-water connectors |
| 2. Vent-valve | 6. Allowance for right-angle cable connector |
| 3. Earth (ground) screw | 7. Backing-port |
| 4. Electrical supply connector | |

Figure 5 - EXT250 Turbomolecular Pump dimensions (mm)

3 INSTALLATION

WARNING

Safely route all vacuum, vent/purge gas and cooling-water pipelines, and all electrical cables and wires, so that people cannot trip over them.

3.1 Unpack and inspect

The pump is packed to prevent damage in transit. Take care when you unpack the pump to avoid excessive shocks which could damage the bearings and reduce the life of the pump. The pump is supplied with the inlet and outlet sealed to prevent entry of dust and vapour. Do not remove these seals until you are ready to install the pump on your vacuum system.

Remove all packing materials and check the pump. If the pump is damaged, notify your supplier and the carrier in writing within three days; state the Item Number of the pump together with your order number and your supplier's invoice number. Retain all packing materials for inspection. Do not use the pump if it is damaged.

Check that your package contains the items listed in Table 2. If any of these items is missing, notify your supplier in writing within three days.

Qty	Description	Check (✓)
1	Turbomolecular pump	<input type="checkbox"/>
1	Inlet seal or compression gasket	<input type="checkbox"/>

Table 2 - Checklist of items

If the pump is not to be used immediately, store the pump in suitable conditions as described in Section 6.1.

Do not discard the packing materials; retain them to repack the pump when you return it for service.

3.2 Typical installation

A typical pumping system with an EXT pump is shown in Figure 6. When necessary, purge the EXT pump with inert gas as described in Section 3.5.

The accessories available for these EXT pumps are detailed in Section 7; the accessories are shown in Figure 8.

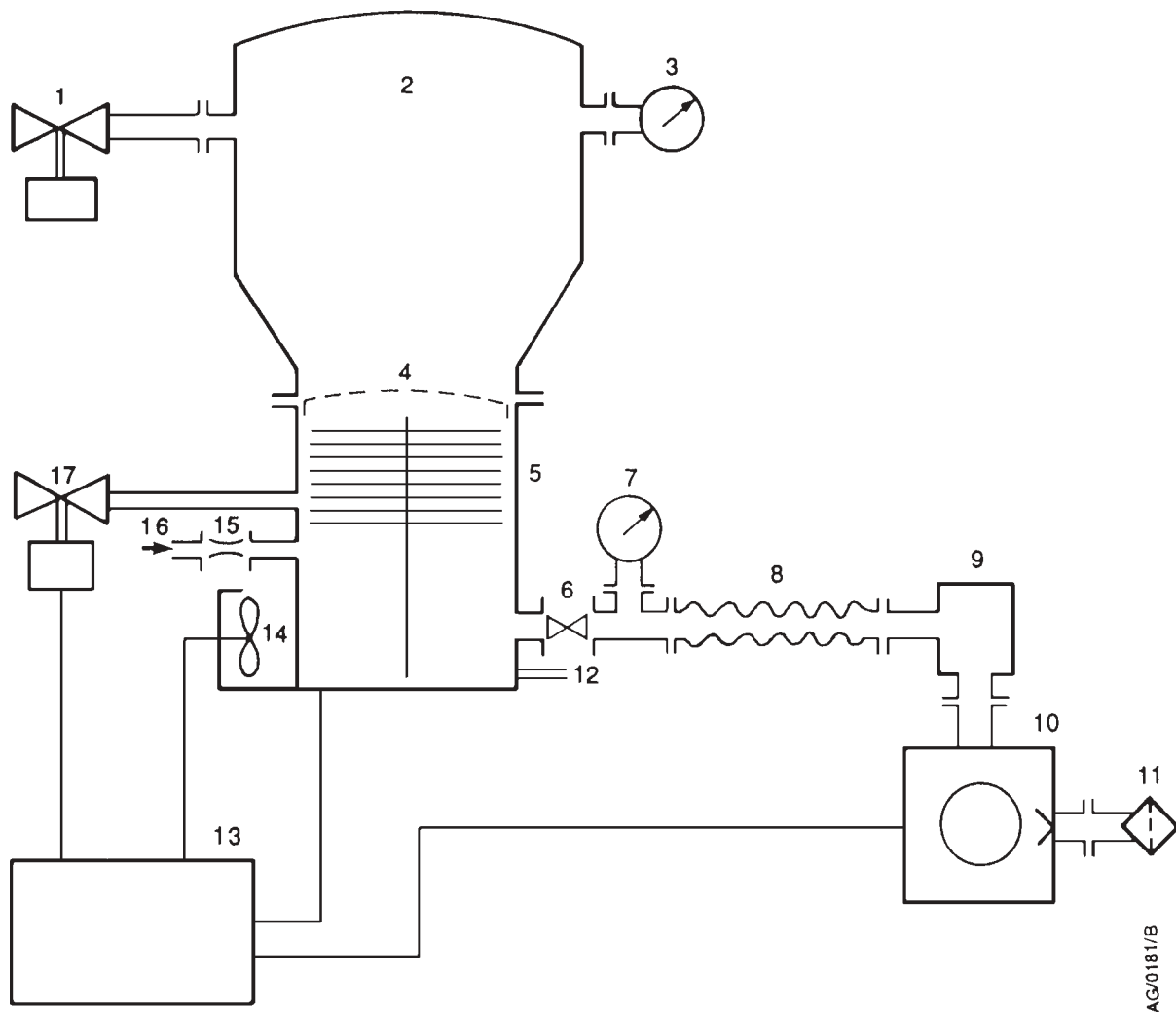

AG/0181/B

- | | | |
|--|-------------------------|--------------------------------|
| 1. Alternative position for vent-valve | 6. Backing valve | 12. Cooling water connectors |
| 2. Vacuum system | 7. Vacuum gauge | 13. EXC Controller |
| 3. High-vacuum gauge | 8. Flexible bellows | 14. Air-cooler |
| 4. Inlet-screen | 9. Foreline trap | 15. PRX10 purge restrictor |
| 5. EXT pump | 10. Rotary backing pump | 16. Regulated purge gas supply |
| | 11. Mist filter | 17. Vent-valve |

Figure 6 - Typical pumping system

3.3 Connect to the vacuum system

WARNING

Install the pump in the vacuum system before you connect the EXC Controller. This will ensure that the pump cannot operate and injure people during installation.

3.3.1 Inlet-screen

Do not remove the inlet-screen unless you can be sure that there is no danger that debris can fall into the pump. In order to avoid the danger of injury from the rotor blades, do not remove the inlet-screen until you are ready to mount the pump onto your system. If the screen is removed, the pumping speed will increase by approximately 10%. It is not possible to remove the inlet-screen from a pump with an NW inlet-flange.

To remove the inlet-screen from pumps with ISO or CF flanges, carefully extract it from the inlet-flange using a bent wire hook. To replace a screen which has been removed, install it as shown in Figure 7, with the BOC Edwards logo uppermost. Ensure that the dimples on the rim of the screen engage in the groove in the pump flange. If necessary, gently bend the tags of the screen outwards to ensure a tight fit.

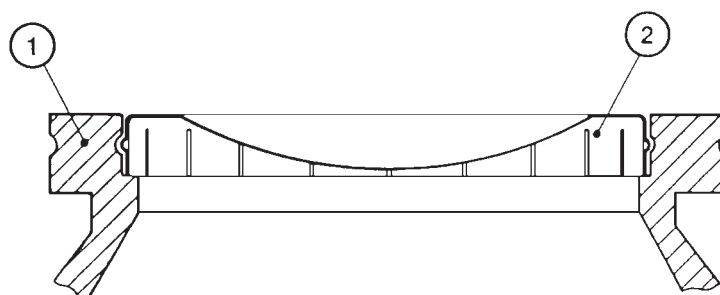

AGC0059/A

1. EXT inlet-flange
2. Inlet-screen

Figure 7 - Correct installation of the inlet-screen

3.3.2 Mechanical fixing

WARNING

Do not operate the EXT pump until it is securely fixed. If the pump seizes, the stored energy of the rotor can cause rapid movement of the pump, which may cause damage and injury to people.

There are two ways in which the EXT pump can be securely fixed. Ideally, the EXT pump should be securely fixed by its inlet-flange to a rigid, firmly fixed vacuum system: see Section 3.3.4. If this is not possible because of the nature of the vacuum system, the base of the EXT pump must be securely fixed to a firm support: see Section 3.3.3.

3.3.3 Base mounting

Ensure that the base of the pump is securely fixed to a firm support (refer to Figures 4 and 5 for the fixing hole details). If the pump supports the weight of the vacuum system, the mass of the vacuum system must be no more than 10 kg for an EXT70 pump, or no more than 20 kg for an EXT250 pump.

You must also ensure that your mounting method meets the following requirements, so that the EXT pump will remain secure in the event of a pump seizure:

- The support mounting must be able to withstand a destructive torque of 333 Nm for an EXT70 pump or 620 Nm for an EXT250 pump.
- Fit cap-head fixing screws through the tapped fixing-holes in the base of the pump (see Figures 4 and 5): use M4 screws for an EXT70 pump, and use M5 screws for an EXT250 pump.
- The fixing screws must comply with ISO 898-1, with a strength class of 12.9 (nominal tensile strength 1200 MPa).
- The fixing screw engagement length must be 6 mm or more.
- Tighten the fixing screws to a torque of 6 Nm (0.61 kgf m) on EXT70 pumps, and to a torque of 12 Nm (1.22 kgf m) on EXT250 pumps.

3.3.4 Inlet connection and orientation

The EXT pump can be fixed to the vacuum system by the inlet-flange. The pump can be mounted in any attitude from vertical and upright through to horizontal ($\pm 2^\circ$). If the pump is mounted horizontally and you use a rotary vane pump to back the EXT pump, the backing port must point vertically downwards ($\pm 20^\circ$) to reduce the risk of contamination from the backing pump oil.

Make sure that the pump-inlet and all components fitted to the pump-inlet are clean and dust-free. If the pump-inlet is not kept clean, the pump-down time may be increased.

The inlet-connection of the EXT pump is a CF flange, an ISO flange or an NW flange:

- If the pump has a CF flange, use the copper compression gasket supplied with the pump and use a full complement of bolts to connect the inlet-flange of the pump to the vacuum system.
- If the pump has an ISO flange, use the BOC Edwards trapped 'O' ring supplied with the pump and use a minimum of four claw clamps to connect the inlet-flange of the pump to the vacuum system. Ensure that each claw clamp is tightened to a torque of 10 Nm or more.

Alternatively, use a rotatable collar and the trapped 'O' ring supplied with the pump to connect the inlet-flange of the pump to the vacuum system; use a full complement of bolts with the rotatable collar.

- If the pump has an NW flange, use the Co-Seal supplied with the pump and a suitable NW clamp to connect the inlet-flange of the pump to the vacuum system.

Ensure that no torque or other forces are transmitted to the pump from the vacuum system or the associated pipelines.

If necessary, fit an inlet vibration isolator between the pump-inlet and the vacuum system: refer to Section 7.4.8 for the Item Numbers, and refer to the instruction manual supplied with the vibration isolator for installation details. If you fit a vibration isolator, you must securely fix the base of the EXT pump as described in Section 3.3.3.

Note: The first time you pump down the system to vacuum, you must re-tighten the bolts which secure the inlet-flange.

3.3.5 Backing connection

Use suitable vacuum tubing and connectors to connect the NW flange of the backing-port to your backing-pump. If necessary, use flexible pipe or bellows to reduce the transmission of vibration from the backing-pump to the EXT pump.

We recommend that you use a BOC Edwards two-stage backing-pump. The backing-pump can also be controlled by the EXC Controller. The minimum size of the backing-pump required is given in Table 1. You may have to use a larger backing-pump if you run the pump at a high inlet pressure or high throughput or if you purge the pump with more than 25 sccm ($0.42 \text{ mbar l s}^{-1}$, 42 Pa l s^{-1}) of purge gas.

Do not use the EXT pump with a backing pressure below $1 \times 10^{-4} \text{ mbar}$ ($1 \times 10^{-2} \text{ Pa}$). Lower backing pressures will increase the evaporation rate of the lubricating oil and so will reduce the life of the bearings.

3.4 Vent-valve connection and control

When you design your system and when you install a vent-valve, take note of the information in Sections 1.3 and 2.3. You can vent the EXT pump and your vacuum system by any of the following methods:

- Use the manual vent-valve supplied.
- Use a TAV5 solenoid vent-valve accessory (see Section 7) in place of the manual vent-valve, together with a vent-restrictor, if necessary.
- Use a TAV5 vent-valve connected to a convenient flange on your vacuum system, with a vent-restrictor, if necessary.
- Use an alternative valve connected to your vacuum system, together with a vent-restrictor, if necessary.

If you use the manual vent-valve, you must open the vent-valve only after the EXT pump speed has fallen to 50% of full rotational speed.

If you use the TAV5 vent-valve, you can only vent the EXT pump when it is at full speed if the vacuum system has a volume of 5 litres or more. If the volume of your vacuum system is less than 5 litres, you can incorporate a suitable restrictor (see Table 3) and vent the pump when it is at full speed. Alternatively, if you do not fit a restrictor, you can use the EXC Controller to control the vent-valve and configure the EXC Controller to open the vent-valve after the EXT pump speed has fallen to 50% of full rotational speed: do not select the 'Vent On Stop' option (refer to the EXC Controller instruction manual for more information).

If you use another vent-valve, you must ensure that you have a suitable vent-restrictor fitted to suit your vacuum system to limit the rate of pressure rise: refer to Table 3. If you do not have a suitable vent-restrictor fitted, you must open the vent-valve only after the speed of the EXT pump has fallen to 50% of full rotational speed.

If you connect the vent-valve to your vacuum system, select a point upstream of the EXT pump to prevent backstreaming of oil from the backing pump. Do not connect the vent-valve to the backing pipeline. Connect the inlet of the vent-valve to the vent gas supply (refer to Section 2.3 for the vent gas specification).

Note: If you use a vent-restrictor, you may find that the time required to vent your system is unacceptably long. You may be able to reduce the vent time if you use an unrestricted vent port without a vent-restrictor and wait until the pump speed has fallen to 50% of full rotational speed before you vent the pump.

Vacuum system volume (l)	Orifice diameter (mm)
< 20	≤ 1.0
< 10	≤ 0.7
< 5	≤ 0.5
< 2.5	≤ 0.35
< 1.25	≤ 0.25

Table 3 - Vent-valve orifice diameter (with atmospheric pressure at the inlet of the vent-valve)

3.5 Purge gas connection (EXT250 only)

3.5.1 Connect the purge gas

If you want to supply a purge gas to the pump, remove the purge plug from the purge-port, fit a vent port adaptor (see Section 7.4) to the purge-port, then connect your purge gas supply to the vent port adaptor. Your purge gas must comply with the specification given in Section 2.4.

You must limit the flow rate of the purge gas to the allowed range, also specified in Section 2.4. To limit the flow rate, use a flow controller or a pressure regulator and calibrated flow restrictor.

The PRX10 purge restrictor accessory (see Section 7.3) is suitable for this purpose. Adjustment of the PRX10 is described in the instruction manual supplied with the accessory.

3.5.2 Recommended purge gas flow

The recommended purge gas flow for typical applications is 25 sccm ($0.42 \text{ mbar l s}^{-1}$, 42 Pa l s^{-1}). This flow will protect the pump when you pump oxygen in concentrations above 20% by volume.

3.6 Electrical installation

WARNING

You must electrically bond the EXT pump to earth (ground): use the earth (ground) screw provided on the pump (Figure 4, item 2 and Figure 5, item 3).

Always make the electrical connections to the EXT pump after the pump has been installed on your vacuum system.

The EXC Controller provides the electrical supply to the EXT pump through the multiway pump-to-controller cable. Connect and lock the bayonet-connectors at the ends of the cable to the mating connectors on the pump and the EXC Controller.

The EXC Controller is designed to allow a pumping system to be configured in a variety of ways, from a basic manually-operated system to a fully automatic system with remote control. Refer to the instruction manual supplied with the EXC Controller to complete the electrical installation.

3.7 Cooling

CAUTION

When you bake the EXT pump to above 70 °C at the inlet-flange, you must cool the pump by forced-air or water-cooling to prevent damage to the bearing lubricant.

We recommend that, whenever possible, you cool the EXT pump by forced-air or water-cooling, however if necessary you can use natural convection to cool the EXT70 in certain applications. Table 4 shows the acceptable cooling methods which you can use for different applications.

If you use natural convection or forced-air to cool the pump, you must ensure that there is an adequate supply of cooling-air to the pump.

3.7.1 Forced-air cooling

An air-cooler accessory is available for the EXT pumps (refer to Section 7). Fit the air-cooler as described in the instruction manual supplied with it. If you wish to use an alternative fan for air-cooling, ensure that the flow rate is above 40 m³ h⁻¹ (25 cfm) for the EXT70, and above 70 m³ h⁻¹ (40 cfm) for the EXT250.

3.7.2 Water-cooling

The cooling-water supply must comply with the specification given in Section 2.5. Pipes in the water-cooling circuit may become blocked if the cooling-water contains too much calcium carbonate or if it contains particulates which are too large. Corrosion of the water-cooling circuit may occur if there is too little calcium carbonate and oxygen in the water. Good quality drinking water is usually suitable for water-cooling. If in doubt, you must check the quality of your cooling-water supply and, if necessary, provide treatment and filtration.

Connect the cooling-water supply to the water-cooler as described below. Either of the two riffled hose connectors on the water-cooler can be used for the water supply or return connections.

1. Push reinforced hose (approximately 6 mm internal diameter) over the ends of the riffled hose connectors on the water-cooler.
2. Attach the hose with strong hose clips and make sure that they are tightened securely.

Alternatively, unscrew the riffled hose connectors and make direct connections to the 1/8 BSP female threaded fittings.

You must turn off the cooling-water supply when you switch off the pump to prevent condensation of vapours inside the pump. The EXC Controller can operate a solenoid-valve for this purpose.

When you remove the EXT pump for maintenance or when you replace the EXT pump, you can unscrew the two M4 cap-head fixing-screws to remove the water-cooler from the pump; you do not have to break the cooling-water circuit. Make sure that there is a layer of thermal contact grease on the water-cooler before you fit it to the pump.

Application conditions	Cooling method	
	EXT70	EXT250
Ambient temperature < 30 °C, light pumping duty with inlet-flange temperature < 70 °C	Natural convection, forced-air or water-cooling	Forced-air or water-cooling
Ambient temperature 30 to 35 °C or inlet-flange temperature > 70 °C, light pumping duty	Forced-air or water-cooling	Forced-air or water-cooling
During bakeout band operation, light pumping duty	Forced-air or water-cooling	Forced-air or water-cooling
With continuous high gas throughput	Forced-air or water-cooling	Forced-air or water-cooling
When the EXT pump is cycled repeatedly from atmospheric to ultimate pressure	Forced-air or water-cooling	Forced-air or water-cooling
Combinations of high ambient temperature, bakeout band operation, high gas throughput and repeatedly cycled operation	Water-cooling	Water-cooling

Table 4 - Pump cooling methods for different applications

4 OPERATION

WARNING

Do not disconnect the pump-to-controller cable when the EXT pump is operating. If you do, there may be a risk of injury or death by electric shock.

WARNING

Do not expose any part of your body to vacuum. If you do, you may be injured.

4.1 Start-up

Use the procedure below to start up a basic, manually-controlled pumping system with a manual vent-valve and an EXC Controller. Refer to the EXC Controller instruction manual where the backing-pump and accessories are automatically controlled by the EXC Controller.

1. Turn the manual vent-valve clockwise to close it.
2. Turn on the cooling-water supply (if water-cooling is used).
3. Start the backing-pump.
4. When the vacuum system pressure is approximately 1 mbar (1×10^2 Pa) or less, press the Start/Stop button on the EXC Controller to start the EXT pump.
5. The pump will then accelerate to full operating speed. When this has been reached, the upper LED of the speed indicator on the front panel of the EXC Controller will light.

Note: The first time you pump down the system to vacuum, you must re-tighten the bolts which secure the inlet-flange: refer to Section 3.3.4.

4.2 Stand-by

You can press the Standby button on the EXC Controller to operate the EXT pump at reduced rotational speed. Select Standby before or after Start-up, for any of the following reasons:

- To extend pump-bearing life and still maintain adequate vacuum pumping performance (for example, when you leave a system under vacuum over holiday periods)
- To increase system pressure or to extend the maximum inlet pressure range of the pump where this suits a particular process
- To avoid pump excitation of any resonances which may exist on sensitive instrumentation.

4.3 Shut-down

Note: In an emergency only, open the vent-valve quickly to decelerate the pump rotor in the shortest possible time.

Use the procedure below to shut down a basic, manually-controlled pumping system with a manual vent-valve and an EXC Controller. Refer to the EXC Controller instruction manual where the backing-pump and accessories are automatically controlled by the EXC Controller.

1. Switch off the backing-pump and press the Start/Stop button on the EXC Controller to switch off the EXT pump.
2. When the EXT pump rotational speed has fallen to below 50% of full rotational speed, turn the manual vent-valve anticlockwise to open it. Ensure that the rate of pressure rise does not exceed the allowed rate of pressure rise, otherwise you can damage the pump: refer to Sections 1.3 and 2.3.
3. If water-cooling is in use, turn off the cooling-water supply.

4.4 Safety interlocks and control system

The pump protection and safety interlock features are listed below. Refer to the instruction manual supplied with the EXC Controller for a full description of these features :

- The EXC Controller monitors the temperature of the EXT pump and the electrical power consumption of the pump. If the EXC Controller detects excessive power consumption or temperature, the rotational speed of the pump motor is reduced until the power and temperature return to normal
- If the rotational speed is reduced to 50% of nominal speed, then the pump is stopped immediately (or after a user defined time delay) and the Fail LED on the EXC Controller lights
- If pump rotational overspeed is detected by the EXC Controller, the pump is stopped immediately and the FAIL LED on the EXC Controller lights.

If the Fail LED lights, switch off the backing-pump immediately and vent the EXT pump. Once the EXT pump has stopped, rectify the cause of the failure (refer to Section 5.5), press the EXC Controller Start/Stop button to reset the Fail condition, and restart the EXT pump. If the pump is hot, allow sufficient time for it to cool before you restart it.

4.5 Bakeout

CAUTION

When you bake the EXT pump to above 70 °C at the inlet-flange, you must cool the pump by forced-air or water-cooling, to prevent damage to the bearing lubricant.

If you heat your EXT pump (and your vacuum system), you will speed up the degassing process so that the pump will reach ultimate vacuum in the shortest possible time. If you heat the pump, this will also prevent condensation of vapours inside the pump.

You can use the BOC Edwards BX bakeout band to heat the pump (refer to Section 7). Fit the band around the pump, just below the inlet-flange. When you bake the pump or the system, make sure that the temperature of the inlet-flange does not exceed 100 °C.

If you bake your vacuum system and the temperature of the system exceeds 200 °C, you must put a radiation shield between the system and the EXT pump. This radiation shield will reduce the heat radiated onto the pump rotor.

Typically, a bakeout of four hours is long enough to remove water condensation from the pump. However, the bakeout time will depend on the amount of condensation in the pump and the vacuum system, and the ultimate pressure you want to achieve.

5 MAINTENANCE

WARNING

Disconnect the pump from the EXC Controller before you remove the pump from your vacuum system for maintenance or fault-finding procedures.

5.1 Introduction

The maintenance operations for the EXT Turbomolecular pumps are described in the following sections. The ISX inlet-screen, the WCX water-cooler and inlet-flange seals are available as spares (refer to Section 7); fit these spares as described in Section 3.

5.2 Bearing life

When supplied, the pump contains sufficient lubricant to supply the bearings for life. No routine maintenance is therefore required between bearing replacements. The bearings are not user-serviceable. The bearings will need to be replaced when they reach the end of their service life. This is typically more than 20,000 hours, but may be less depending upon the type of pumping duty on which the pump was used.

When the bearings need replacement, we recommend that you exchange your pump for a factory reconditioned replacement. Alternatively, you can send your pump to a BOC Edwards Service Centre to have the bearings replaced.

When you return EXT pumps to BOC Edwards Service Centres please obey the procedure included at the end of this manual. However, the instruction to drain all fluids does not apply to the lubricant in the EXT pump oil-reservoirs.

5.3 Rotor life

The life of the EXT pump rotor is typically 40,000 to 50,000 cycles (of acceleration to full speed, and then deceleration to a stop). The pump rotor is not user-serviceable.

We therefore recommend that you exchange your pump for a factory reconditioned replacement every 20,000 cycles, or 10 years of use, whichever occurs first. Alternatively, you can send your pump to a BOC Edwards Service Centre for a major service (which will include rotor replacement).

When you return EXT pumps to BOC Edwards Service Centres please obey the procedure included at the end of this manual. However, the instruction to drain all fluids does not apply to the lubricant in the EXT pump oil-reservoirs.

5.4 Clean the pump

WARNING

Clean the external surfaces of the EXT pump in a well-ventilated location. When you use cleaning solutions and solvents to clean the pump, observe all precautions specified by the manufacturer. Avoid inhalation of any particulates which may be present in the pump.

CAUTION

Do not attempt to clean any parts of the EXT pump other than the external surfaces. Organic solvents may damage internal pump components. Do not use abrasive materials to clean any part of the pump.

If the inside of the EXT pump is contaminated, it may not be possible to achieve the specified ultimate vacuum, or pump-down time may increase. In these circumstances, you should return the pump to a BOC Edwards Service Centre, where the pump will be dismantled and cleaned. Use the procedure given in the forms at the end of this manual to return the pump.

You can use any organic solvent to clean the external surfaces of the EXT pump. We recommend that you use non-CFC solvents, such as isopropanol or ethanol. Use a cleaning solution which is suitable for the contaminants on the pump surfaces.

For environmental reasons, keep wastage of cleaning solutions and solvents to a minimum.

5.5

Fault finding

Symptom	Check	Action
The pump does not rotate. After pressing start - Fail LED not lit.	<p>Is the EXC Controller power LED lit ?</p> <p>Is the EXC Controller Start/Stop LED flashing ?</p> <p>Is the EXC Controller first speed indication LED lit ?</p>	<p>If not, check that the electrical supply is on, check that the switch at the rear of the EXC Controller is on, check the fuse in the rear of the EXC Controller.</p> <p>If all of the above are OK then the EXC Controller is faulty. Consult BOC Edwards or your supplier</p> <p>If so, check that the correct links are made on the EXC Controller logic interface (refer to the instruction manual supplied with the EXC Controller).</p> <p>Check that any system interlocks are correctly made (refer to the instruction manual supplied with the EXC Controller).</p> <p>Check that the pump-to-controller cable is connected.</p> <p>If all of the above are OK then consult BOC Edwards or your supplier.</p> <p>If not, the EXC Controller is faulty. If lit, then the EXT pump is faulty. Consult BOC Edwards or your supplier.</p>
The EXC Controller trips into Fail - at any speed.	Are the system interlocks correctly connected ?	Ensure that the system interlocks do not open after the EXT pump has started.
The EXC Controller trips into Fail during the ramp-up and before 50% speed is reached.	Is the inlet pressure too high ?	If so, reduce the pumping load, or check for a gross leak into the system.

Table 5 - Fault finding

Symptom	Check	Action
The EXC Controller trips into Fail during the ramp-up and before 50% speed is reached (continued).	<p>Is the EXT pump running too hot ?</p> <p>Does the rotor rotate freely ?</p> <p>None of the above.</p>	<p>Increase the cooling-water flow or decrease the water temperature or do both. You may need to change from air-cooling to water-cooling. (Refer to Section 2 for maximum inlet pressure and cooling requirements). Check that external heat sources (such as system bakeout heaters) are not excessive.</p> <p>If not, the EXT pump-bearings are damaged. Consult BOC Edwards or your supplier.</p> <p>Increase the timer setting (refer to the instruction manual supplied with the EXC Controller). If the EXC Controller still trips into Fail consult BOC Edwards or your supplier.</p>
The EXC Controller trips into Fail after 50% speed has been reached - the first two speed LEDs are lit.	<p>Is the pressure too high ?</p> <p>Is the EXT pump running too hot ?</p> <p>Does the EXT pump rotor rotate freely ?</p>	<p>If so, reduce the pumping load or check for a gross leak into the system.</p> <p>If the high gas load is temporary, configure the EXC Controller to delay the Fail trip on 50% speed and set an appropriate delay time (refer to the instruction manual supplied with the EXC Controller).</p> <p>Increase the cooling-water flow or decrease the water temperature or do both. You may need to change from air-cooling to water-cooling.</p> <p>If not, the EXT pump-bearings are damaged. Consult BOC Edwards or your supplier.</p>
The EXC Controller trips into Fail - all the speed LEDs are lit.	-	Consult BOC Edwards or your supplier.

Table 5 - Fault finding (continued)

Symptom	Check	Action
Ultimate pressure cannot be reached.	<p>Is the pressure limited by water vapour ?</p> <p>Are any of the vacuum gauges contaminated ?</p> <p>Is the pumping speed insufficient (due to poor conductance between the pump and the gauge or too large a chamber) ?</p> <p>Is the backing pressure < 0.2 mbar (20 Pa) ?</p> <p>Is the high-vacuum area of the system contaminated ?</p> <p>Check the rest of your system for leaks and contamination.</p> <p>Remove the pump from the system and test the ultimate pressure of the pump alone (see Section 2 for specification).</p>	<p>Bake the system and pump.</p> <p>If so, clean or replace them.</p> <p>Increase the conductance or reduce the volume.</p> <p>If not, check for backing line leaks. If the throughput is high, you may need a larger backing-pump.</p> <p>If so, clean the high-vacuum system.</p> <p>If found, clean the contaminated areas and repair the leaks.</p> <p>If poor, check the pump for contamination and if necessary return the pump as described in Section 5.4. Leak-check the pump. If the leak rate $> 1 \times 10^{-7}$ mbar l s⁻¹ (1×10^{-5} Pa l s⁻¹) consult BOC Edwards or your supplier.</p>
The EXT is very noisy or there is excessive vibration or both.	<p>Is the pump rotational speed the same as the resonant frequency of the attached system ?</p> <p>Is the vibration being transmitted from the rotary pump ?</p> <p>Is the noise irregular and getting progressively worse ?</p> <p>Is the EXT making a constant high-pitched noise ?</p>	<p>If so, change the natural frequency of your system or isolate the pump using flexible bellows.</p> <p>If so, fit flexible bellows or a vibration isolator in the backing line.</p> <p>If so, a bearing is defective. Consult BOC Edwards or your supplier.</p> <p>If so, the rotor is out of balance. Consult BOC Edwards or your supplier.</p>

Table 5 - Fault finding (continued)

6 STORAGE AND DISPOSAL

6.1 Storage

Use the following procedure to store the pump.

1. Place protective covers over the inlet, outlet, purge and vent ports.
2. Place the pump in its packing materials. For fastest pump-down when the pump is put back into service, seal the pump inside a plastic bag together with a suitable desiccant.
3. Store the pump in cool, dry conditions until required for use. When required, prepare and install the pump as described in Section 3.
4. Keep the pump upright at all times to prevent the drainage of oil from the bearing reservoir.
5. Avoid long-term storage if possible. When long-term storage is necessary, the pump should be set up and run for at least eight hours every six months.

6.2 Disposal

Dispose of the EXT Turbomolecular Pump and any components and accessories safely in accordance with all local and national safety and environmental requirements.

Take particular care with any components which have been contaminated with dangerous process substances.

7 SERVICE, SPARES AND ACCESSORIES

7.1 Introduction

BOC Edwards products and spares are available from BOC Edwards companies in Belgium, Brazil, China, France, Germany, Israel, Italy, Japan, Korea, Singapore, United Kingdom, U.S.A and a worldwide network of distributors. The majority of these centres employ Service Engineers who have undergone comprehensive BOC Edwards training courses.

Order spare parts and accessories from your nearest BOC Edwards company or distributor. When you order, please state for each part required:

- Model and Item Number of your equipment
- Serial number (if any)
- Item Number and description of the part

7.2 Service

BOC Edwards products are supported by a world-wide network of BOC Edwards Service Centres. Each Service Centre offers a wide range of options including: equipment decontamination; service exchange; repair; rebuild and testing to factory specifications. Equipment which has been serviced, repaired or rebuilt is returned with a full warranty.

Your local Service Centre can also provide BOC Edwards engineers to support on-site maintenance, service or repair of your equipment.

For more information about service options, contact your nearest Service Centre or other BOC Edwards company.

7.3 Spares

7.3.1 ISX inlet-screen

An inlet-screen is fitted to your pump as supplied to prevent damage from the entry of debris into the pump. The Item Numbers of replacement inlet-screens are given below. Select the inlet-screen according to the pump inlet-flange size. You cannot replace the inlet-screen on an EXT70 pump with an NW inlet-flange

Flange size	Inlet-screen	Item Number
DN63ISO-K/DN63CF	ISX63	B580-51-005
DN100ISO-K/DN100CF	ISX100	B580-51-001

7.3.2 WCX water-cooler

A water-cooler is fitted to your pump as supplied. The Item Number of a replacement water-cooler which fits all pumps is given below.

Pump	Water-cooler	Item Number
EXT70/EXT250	WCX500	B736-00-121

7.3.3 Inlet-flange seals

EXT pumps are supplied with a seal to match the inlet-flange. The Item Numbers of replacement seals are listed below.

Flange size	Inlet seal	Item Number
DN63ISO-K	ISO63 trapped 'O' ring, fluoroelastomer	B271-58-170
DN40NW	DN40NW Co-Seal, fluoroelastomer	B271-58-453
DN50NW	DN50NW Co-Seal, fluoroelastomer	B271-58-466
DN100ISO-K	ISO100 trapped 'O' ring, fluoroelastomer	B271-58-171
DN100CF	100CF Copper gasket (pack of 5)	C082-00-003
DN63CF	63CF Copper gasket (pack of 5)	C081-00-003

7.4 Accessories

7.4.1 Installation

The accessories available for use with the EXT turbomolecular pumps are described in the following Sections. Figure 8 shows how the accessories are fitted to an EXT pump.

7.4.2 EXC Controller

The BOC Edwards EXC Controllers provide the facilities necessary for operating a pumping system based on an EXT pump. The following EXC Controllers are available:

Controller	Voltage	Item Number
EXC120	100-240 V	D396-16-000
EXC100	100-240 V	D396-20-000
EXC300	100-120/200-240 V	D396-14-000

7.4.3 Pump-to-controller cable

A pump-to-controller cable must be used with each pump. It is not supplied with the EXT Pump or the EXC Controller. The following cables are available:

Cable	Length	Item Number
Pump-to-controller	1 m	D396-18-010
Pump-to-controller	3 m	D396-18-030
Pump-to-controller	5 m	D396-18-050

7.4.4 BX bakeout band

A BX bakeout band accelerates the degassing of the pump to enable it to achieve lower pressures. It may also be used to protect the pump from condensation of contaminants. The bakeout bands are available in 110-120 V or 220-240 V versions and may be powered from a rear panel socket on the EXC Controller.

Pump	Bakeout band	Item Number
EXT70	BX70 (110 V)	B580-52-040
	BX70 (240 V)	B580-52-060
EXT250	BX250 (110 V)	B580-52-041
	BX250 (240 V)	B580-52-061

7.4.5 FL20K foreline trap

The foreline trap minimises oil vapour backstreaming from the backing-pump and is recommended where the highest system cleanliness is required.

Foreline trap	Item Number
FL20K	A133-05-000

7.4.6 TAV vent-valve and vent-port adaptor

A solenoid-operated vent-valve is available for system venting. The valve is 24 V d.c., normally-open, and can be driven automatically from the EXC Controller. The solenoid-valve is fitted in place of the manual-valve, or alternatively can be fitted with an adaptor (supplied with the valve) and be used with any suitable NW10 flanged port on your vacuum system.

An NW10 - $\frac{1}{8}$ inch BSP male adaptor is also available. This adaptor allows the vent-port to be used with any suitable NW10 fitting: see Figure 8, item 13.

Product	Item Number
TAV5 vent-valve	B580-66-010
NW10 - $\frac{1}{8}$ inch male adaptor	B580-66-011

7.4.7 ACX air-cooler

An ACX air-cooler can be fitted to all pumps in the EXT range. However, please refer to Section 3 to check the suitability of air-cooling in a particular application.

Pump	Air-cooler	Item Number
EXT70	ACX70	B580-53-050
EXT250	ACX250H	B580-53-160

AW/6001/A

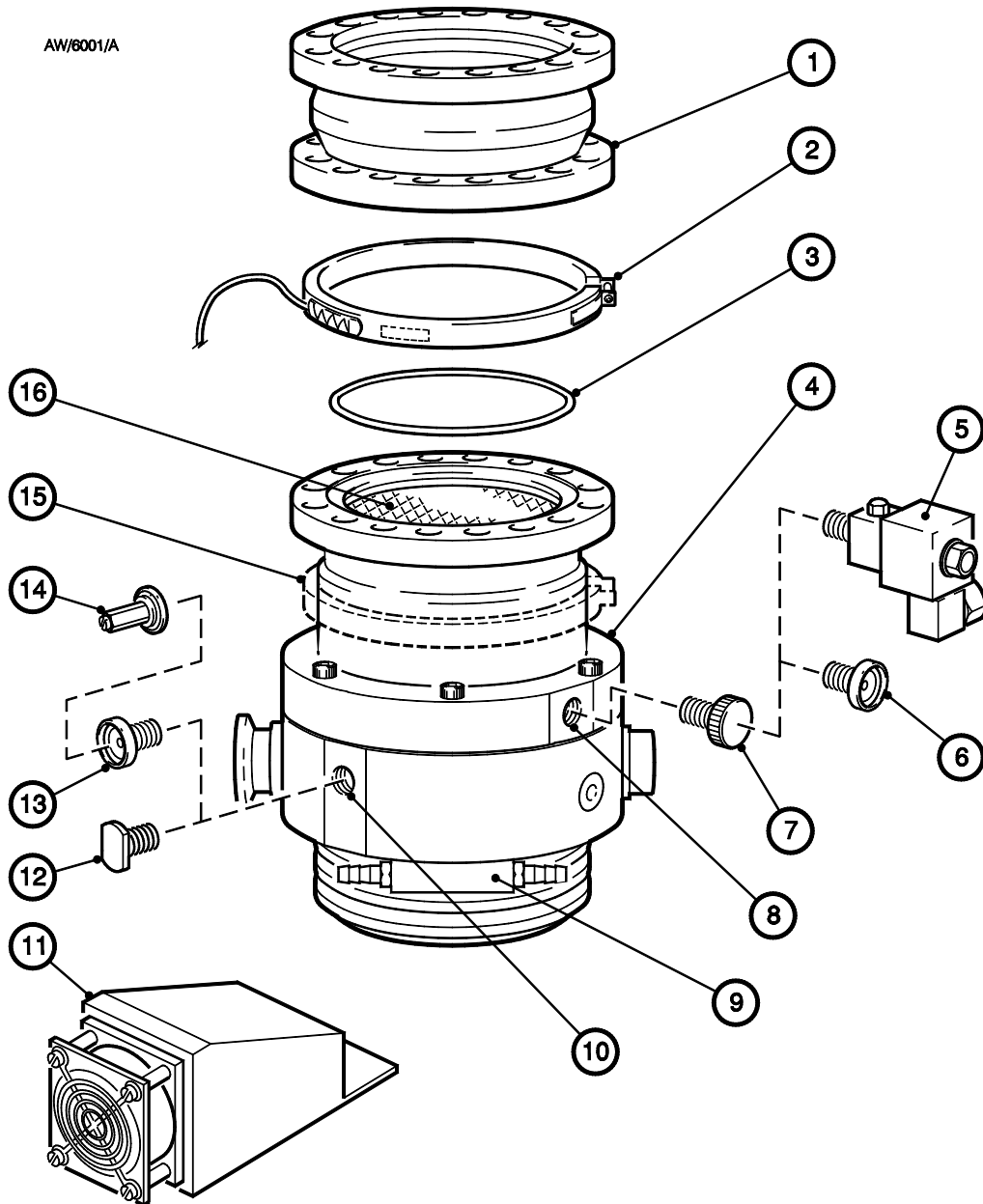

- | | | |
|---------------------------------|---------------------------------|-----------------------------|
| 1. Vibration isolator | 7. Manual vent-valve (supplied) | 12. Purge plug (supplied) |
| 2. Bakeout band | 8. Vent-port | 13. DN10NW adaptor |
| 3. Inlet-flange seal (supplied) | 9. Water-cooler (supplied) | 14. Purge restrictor |
| 4. EXT pump | 10. Purge-port | 15. Bakeout band position |
| 5. Solenoid vent-valve | 11. Air-cooler * | 16. Inlet-screen (supplied) |
| 6. DN10NW adaptor | | |

* The design of the air-cooler varies according to pump model

Figure 8 - Installation of optional accessories (and spares)

7.4.8 Vibration isolators

In applications where the small amount of vibration generated by the turbomolecular pump is a problem, a vibration isolator can be fitted. The isolator consists of two special flanges separated by a flexible bellows and a rubber, anti-vibration, outer collar. The isolator required is dependent on the pump flange size.

Flange size	Item Number
DN63ISO-K	B581-15-000
DN63CF	B581-01-000
DN100ISO-K	B581-20-000
DNI00CF	B581-05-000

7.4.9 PRX purge restrictor

A modified DN10NW centring-ring is available to filter the purge gas and restrict its flow rate to the recommended flow of 25 sccm. The restrictor is suitable for all EXT pumps fitted with a purge-port.

Purge restrictor	Flange size	Item Number
PRX10	NW10	B580-65-001

7.4.10 VRX vent-restrictor

Use a VRX fixed orifice vent-restrictor to restrict the flow of vent gas into the EXT pump. You can fit a vent-restrictor to the inlet of a TAV5 vent-valve or PRX10 purge-restrictor. Refer to Section 3.4 for information on the selection of the correct VRX vent-restrictor.

Vent-restrictor	Orifice diameter (mm)	Item Number
VRX10	0.1	B580-66-021
VRX20	0.2	B580-66-022
VRX30	0.3	B580-66-023
VRX50	0.5	B580-66-024
VRX70	0.7	B580-66-025

Return of BOC Edwards Equipment - Procedure

INTRODUCTION

Before returning your equipment, you must warn BOC Edwards if substances you used (and produced) in the equipment can be hazardous. This information is fundamental to the safety of our Service Centre employees and will determine the procedures employed to service your equipment.

Complete the Declaration (HS2) and send it to BOC Edwards before you dispatch the equipment. It is important to note that this declaration is for BOC Edwards internal use only, and has no relationship to local, national or international transportation safety or environmental requirements. As the person offering the equipment for shipment, it is your responsibility to ensure compliance with applicable laws.

GUIDELINES

- Equipment is '**uncontaminated**' if it has not been used, or if it has only been used with substances that are not hazardous. Your equipment is '**contaminated**' if it has been used with any substances classified as hazardous under EU Directive 67/548/EEC (as amended) or OSHA Occupational Safety (29 CFR 1910).
- If your equipment has been used with radioactive substances, biological or infectious agents, mercury, polychlorinated biphenyls (PCB's), dioxins or sodium azide, you must decontaminate it before you return it to BOC Edwards. You must send independent proof of decontamination (for example a certificate of analysis) to BOC Edwards with the Declaration (HS2). Phone BOC Edwards for advice.
- If your equipment is contaminated, you must either:
 - Remove all traces of contamination (to the satisfaction of laws governing the transportation of dangerous/hazardous substances).
 - Or, properly classify the hazard, mark, manifest and ship the equipment in accordance with applicable laws governing the shipment of hazardous materials.

Note: Some contaminated equipment may not be suitable for airfreight.

PROCEDURE

1. Contact BOC Edwards and obtain a Return Authorisation Number for your equipment.
2. Complete the Return of BOC Edwards Equipment - Declaration (HS2).
3. If the equipment is contaminated, you must contact your transporter to ensure that you properly classify the hazard, mark, manifest and ship the equipment, in accordance with applicable laws governing the shipment of contaminated/hazardous materials. As the person offering the equipment for shipment, it is your responsibility to ensure compliance with applicable law. **Note: Equipment contaminated with some hazardous materials, such as semiconductor by-products, may not be suitable for airfreight - contact your transporter for advice.**
4. Remove all traces of hazardous gases: pass an inert gas through the equipment and any accessories that will be returned to BOC Edwards. Where possible, drain all fluids and lubricants from the equipment and its accessories.
5. Seal up all of the equipment's inlets and outlets (including those where accessories were attached) with blanking flanges or, for uncontaminated product, with heavy gauge tape.
6. Seal equipment in a thick polythene/polyethylene bag or sheet.
7. If the equipment is large, strap the equipment and its accessories to a wooden pallet. If the equipment is too small to be strapped to a pallet, pack it in a suitable strong box.
8. Fax or post a copy of the Declaration (HS2) to BOC Edwards. The Declaration must arrive before the equipment.
9. Give a copy of the Declaration (HS2) to the transporter. You must tell your transporter if the equipment is contaminated.
10. Seal the original Declaration in a suitable envelope: attach the envelope securely to the outside of the equipment package, in a clear weatherproof bag.

WRITE YOUR RETURN AUTHORISATION NUMBER CLEARLY ON THE OUTSIDE OF THE ENVELOPE OR ON THE OUTSIDE OF THE EQUIPMENT PACKAGE.

Return of BOC Edwards Equipment - Declaration

Return Authorisation Number:

You must:

- Know about all of the substances which have been used and produced in the equipment before you complete this Declaration
- Read the Return of BOC Edwards Equipment - Procedure (HS1) before you complete this Declaration
- Contact BOC Edwards to obtain a Return Authorisation Number and to obtain advice if you have any questions
- Send this form to BOC Edwards before you return your equipment

SECTION 1: EQUIPMENT

Equipment/System Name _____

Part Number _____

Serial Number _____

Has the equipment been used, tested or operated ?

 YES Go to Section 2 NO Go to Section 4

IF APPLICABLE:

Tool Reference Number _____

Process _____

Failure Date _____

Serial Number of Replacement Equipment _____

SECTION 2: SUBSTANCES IN CONTACT WITH THE EQUIPMENT
Are any substances used or produced in the equipment:

- Radioactive, biological or infectious agents, mercury, poly chlorinated biphenyls (PCBs), dioxins or sodium azide? (if YES, see Note 1) YES NO
- Hazardous to human health and safety? YES NO

Note 1 : BOC Edwards will not accept delivery of any equipment that is contaminated with radioactive substances, biological/infectious agents, mercury, PCB's, dioxins or sodium azide, unless you:

- Decontaminate the equipment
- Provide proof of decontamination

YOU MUST CONTACT BOC EDWARDS FOR ADVICE BEFORE YOU RETURN SUCH EQUIPMENT

SECTION 3: LIST OF SUBSTANCES IN CONTACT WITH THE EQUIPMENT

Substance name	Chemical Symbol	Precautions required (for example, use protective gloves, etc.)	Action required after a spill, leak or exposure

SECTION 4: RETURN INFORMATION

Reason for return and symptoms of malfunction _____

- If you have a warranty claim:
- who did you buy the equipment from ? _____
 - give the supplier's invoice number _____

SECTION 5: DECLARATION

Print your name: _____ Print your job title: _____

Print your organisation: _____

Print your address: _____

Telephone number: _____ Date of equipment delivery: _____

I have made reasonable enquiry and I have supplied accurate information in this Declaration. I have not withheld any information, and I have followed the Return of BOC Edwards Equipment - Procedure (HS1).

Note: Please print out this form, sign it and return the signed form as hard copy.

Signed: _____ Date _____

This page intentionally blank.

UNITED KINGDOM**CORPORATE HEADQUARTERS****BOC EDWARDS**

Manor Royal
Crawley
West Sussex
RH10 9LW
Tel +(44) 1293 528844
Fax +(44) 1293 533453

BOC EDWARDS

Wingates Industrial Estate
Great Bank Road
Westhoughton, Bolton
Lancashire
BL5 3SL
Tel +(44) 1942 652652
Fax +(44) 1942 652651

AMERICA (USA)**USA HEADQUARTERS****BOC EDWARDS**

One Edwards Park
301 Ballardvale Street
Wilmington, MA 01887
Tel +(1) 978 658 5410
Toll free (USA only) 1 800 848 9800
Fax +(1) 978 658 7969

3901 Burton Drive
Santa Clara, CA 95054
Tel +(1) 408 496 1177
Fax +(1) 408 496 1188

1810 West Drake Drive
Suite 101
Tempe, AZ 85283
Tel +(1) 602 777 7007
Fax +(1) 602 777 2244

11701 Stonehollow Drive
Suite 100
Austin, TX 78758
Tel +(1) 512 491 6622
Fax +(1) 512 491 0629

3501 Island Avenue
Philadelphia, PA 19153
Tel +(1) 215 365 8653
Fax +(1) 978 753 6846

BELGIUM**BOC EDWARDS**

Bergensesteenweg 709
B1600 Sint-Pieters-Leeuw
Brussels
Tel +(32) 2 363 0030
Fax +(32) 2 363 0064

BRAZIL**BOC DO BRASIL LTDA
DIVISÃO EDWARDS ALTO VACO**

Rua Bernardo Wrona 222
02710 São Paulo-SP
Tel +(55) 11 3952 5000
Fax +(55) 11 3965 2766

CANADA**BOC EDWARDS**

5975 Falbourne Street
Mississauga, Ontario L5R3W6
Canada
Tel +(1) 905 501 2558
Fax +(1) 905 501 1632

12055 Cote de Liesse
Dorval, Quebec H9P1B4
Canada
Tel +(1) 514 631 3501
Fax +(1) 514 631 3502

CHINA**BOC TRADING
(SHANGHAI) CO. LTD.**

23 Fu Te Road (N)
Wai Gao Qiao Free Trade Zone
Pudong
Shanghai, 200131
PRC China
Tel +(86 21) 5866 9618
Fax +(86 21) 5866 9993

FRANCE**BOC EDWARDS**

125 Avenue Louis Roche
92238 Gennevilliers, Cedex
Paris
Tel +(33) 1 47 98 24 01
Fax +(33) 1 47 98 44 54

GERMANY**BOC EDWARDS**

Ammerthalstraße 36
85551 Kirchheim
Munich
Tel +(49) 89 99 19 18 0
Fax +(49) 89 99 19 18 99

HONG KONG S.A.R.**BOC EDWARDS (ASIA)**

12 Chun Yat Street
Tseung Kwan O Industrial Estate
Tseung Kwan O, Kowloon
Hong Kong S.A.R.
Tel +(852) 2372 2640
Fax +(852) 2796 9095

INDIA**BOC EDWARDS**

DIVIN. OF BOC INDIA LIMITED
203 Surya Kiran Building
19 Kasturba Gandhi Marg
New Delhi - 110 001
India
Tel +(91) 11 851 0065
Fax +(91) 11 851 0245

ISRAEL**EDWARDS ISRAEL VACUUM LTD.**

5 Habarzel Blvd
Gat 2000 Industrial Zone
Qiryat Gat 82000
Tel +(972) 8 681 0633
Fax +(972) 8 681 0640

ITALY**BOC EDWARDS**

Via Carpaccio 35
20090 Trezzano sul Naviglio
Milan
Tel +(39) 02 48 4471
Fax +(39) 02 48 401638

JAPAN**HEADQUARTERS****BOC EDWARDS**

Shuwa Shiba Park Building A-3F
2-4-1 Shibakoen Minato-ku
Tokyo, 105-0011
Tel +(81) (0) 3 5470 6530
Fax +(81) (0) 3 5470 6521

KOREA**HEADQUARTERS****SONGWON EDWARDS LTD.**

5th FL. Daewoo Engineering Bldg.
Soonae-dong
Bundang-gu, Sungnam City
Kyungki-do, Korea
Tel +(82) 31 716 7070
Fax +(82) 31 738 1001-3

FACTORY & GV**SONGWON EDWARDS LTD.**

625-7 Upsong-dong
Chunan City
Chungchong Nam-do
Korea
Tel +(82) 41 621 7070
Fax +(82) 41 621 7700

SINGAPORE**BOC EDWARDS (ASIA)**

42 Loyang Drive
Loyang Industrial Estate
Singapore 508962
Tel +(65) 6546 8408
Fax +(65) 6546 8407

TAIWAN, R.O.C.**EDWARDS TECHNOLOGIES
LIMITED**

No. 434 Chung hua Road
Toufen Town, Miaoli County
Taiwan ROC
Tel +(886) 37 611422
Fax +(886) 37 611401

PLEASE CONTACT ANY OF THESE COMPANIES FOR DETAILS OF OTHER SALES AND SERVICE CENTRES IN YOUR AREA.

BOC Edwards is part of BOC Limited. BOC Edwards and the stripe symbol are trade marks of The BOC Group.

© BOC Edwards 2003

Produced by Technical Publicity Techpublicity@edwards.boc.com

<http://www.bocedwards.com>
info@bocedwards.com

 **BOC EDWARDS**